





Nº 83

PRACTICAL HINTS
ABOUT
75
BARN BUILDING

TOGETHER WITH SUGGESTIONS AS TO

THE CONSTRUCTION OF SWINE AND SHEEP
PENS, SILOS AND OTHER FARM
OUTBUILDINGS.

EMBODYING THE EXPERIENCE OF A LARGE NUMBER OF LEADING
AMERICAN STOCKMEN AND FARMERS.

COMPILED BY
J. H. SANDERS,
FOUNDER OF THE BREEDER'S GAZETTE.

CHICAGO:
J. H. SANDERS PUBLISHING Co.
1892.

COPYRIGHT, 1892,
BY J. H. SANDERS PUBLISHING CO.
[ALL RIGHTS RESERVED.]

INTRODUCTORY

This book is designed to be suggestive rather than specific in the help it offers to those who contemplate the construction of buildings for the accommodation of any variety of farm stock, or for the carrying on of some business especially connected with any branch of live-stock husbandry. It is true that all the plans herein presented are accompanied by more or less minute details as to their construction, but after all the chief merit of these plans, as well as of the letter-press matter given in connection therewith, lies in their suggestiveness—the facility with which the various plans presented may be altered, modified, or combined so as to meet the needs and the circumstances of farmers and stock-raisers in every part of our country, whether they be rich or poor, or whether their operations be conducted on a large or small scale. In short, it has been the purpose of the compiler in effect to take the intending builder with him on a tour of inspection among the barns, stables, etc., that have been erected and are used by successful farmers and stock-breeders in various parts of the country, from New York to Nebraska, and while we are looking at the designs to have the owners point out what they consider the merits and demerits of the plans adopted. And assuredly it does not detract from the value of the work that the plans and descriptions as well as the accompanying suggestions are all the work of practical men; all the result of practical experience, and not merely the fanciful conceptions of a theoretical architect, who, sitting in his cozy office, may draft beautiful pictures which will often prove expensive luxuries to those who attempt to carry out these paper designs in a practical way upon the farm. A handsome drawing may not always result in a convenient

and economical structure, although beauty of design in farm-yard buildings should never be lost sight of, for upon this much of the attractiveness of the farmer's home depends. But the comfort, thrift, and health of the animals, economy in the storage of hay, straw, grain, and other foods, and convenience in the feeding and management of the farm animals are the considerations to which all others must be subservient.

In the hope that the plans and designs herewith submitted may be helpful to others, the work is given to the public conscious of the fact that after all a work of this kind can be nothing but a help. And certainly it must be a valuable help to the intending builder to have an opportunity of examining the plans and designs that others have followed. In this volume we show in an hour what otherwise it would require months and even years of travel to learn, and from the wealth of experience herein contained the intending builder may perhaps find something adapted to his needs and circumstances.

J. H. SANDERS.

CHICAGO, March 15, 1892.

TABLE OF CONTENTS.

INTRODUCTORY,	-	-	-	-	5-8
FARM BARNS—General Remarks,	-	-	-	-	9-13
Plans of,	-	-	-	-	13-38
CATTLE BARNS—General Remarks,	-	-	-	-	39-42
Plans of,	-	-	-	-	43-112
HORSE BARNS—General Remarks,	-	-	-	-	113-115
Plans of,	-	-	-	-	115-153
SHEEP BARNS, YARDS, CORRALS, FEEDING RACKS, ETC.,					154-178
SWINE BARNS, PENS, AND DEVICES,	-	-	-	-	179-248
SILOS AND ENSILAGE,	-	-	-	-	249-280
GENERAL INDEX,	-	-	-	-	281-284

GENERAL FARM BARNS.

The plan of barn or stable that is best adapted to the use of the general farmer must necessarily combine to a greater or less degree the features that are especially desirable to those who direct their farming operations toward some particular branch of live-stock husbandry. On nearly every farm in the West cattle, horses, and swine are kept, and sheep-raising is also largely a part of the general farm economy. But the term "general farmer" is an indefinite one, because few farmers devote their attention alike to everything that may be produced upon a farm. One man will make all of his farming operations, to a greater or less degree, subservient to his specialty of some particular variety of live stock; another may desire to maintain only such numbers of horses, cattle, etc., as are, in his opinion, essential to the economical production of his specialty of grains or grasses for the market; but the great bulk of Western farmers pursue a system of mixed husbandry, cultivating the various grains and grasses, and raising more or less of the several kinds of live stock. And as the farming operations lean in a greater or less degree toward any of these as specialties so must the general farm barn be constructed. No cast-iron rules can be laid down, for what may be just the thing for one man under certain circumstances may be very far from what is needed by his neighbor who is differently situated.

The most that can be done, therefore, in a work of this nature is to offer a few suggestions and point out a few principles that are of general application, and to suggest to the intending builder a careful study of the plans herewith submitted, with their several especial adaptations; and thus by taking a little from this and a little from that he may be able to get what is best adapted to his own purpose. Our designs for barns and stables for especial uses are particu-

larly full, explicit and suggestive, and are susceptible of almost numberless modifications. They are reproductions upon paper of structures that have already been built by practical men and submitted to the test of actual use. We have given a number of plans of so-called general farm barns, some of them simple, cheap, and plain, and others quite expensive and elaborate. It is scarcely to be expected that many individual farmers will desire to erect so extensive, so comprehensive, so elaborate, and so costly a structure as that of the Missouri State Agricultural College Farm barn with which our description of plans opens; but this structure is so complete in all its details and so well adapted to all the various uses of a general farm barn that its plan may well be studied by anyone intending to build, and such of its features adopted as may be found especially suited to individual requirements. And the same may be said of many of the other general and special plans submitted.

In the great grain and grass-growing regions of the Central West, where large numbers of live stock are to be cared for, and where building material is often scarce and high-priced, the ideal barn is quite a different structure from that to which our fathers were accustomed a half century ago in the older States and under a more primitive system of agriculture. Here the primary considerations are to provide first, shelter for fodder and for the live stock in such close proximity that the labor of feeding will be reduced to the minimum; and second, a location at once central to the fields, pastures, and the dwelling house, and upon ground either naturally well drained or which may, by a system of tiling, be made so. The importance of location and arrangement with reference to the fields and pastures is a point often overlooked, and much valuable time is frequently wasted in driving stock to and from the barn that might with a very little foresight be saved. Most kinds of stock will naturally seek shelter upon the approach of a storm, and if the pastures are so arranged with reference to the barn, or the barn with reference to the pastures, that this natural instinct can be utilized the labor of housing and sheltering in the case of a sudden severe storm will be greatly reduced and the benefits

of comfortable shelter will frequently be realized when otherwise the stock would of necessity be left shivering in the fields. There is a knack in so arranging these conditions as to secure the greatest degree of convenience; that is, in so planning and constructing barns, yards and fields that the advantages they afford may be utilized with the least possible loss of time and labor. It is not every man who possesses the ability to do this, but the suggestions which accompany many of our plans will be found helpful to all. And so of drainage: the barnyards must be so situated or constructed that they can be kept dry. Tile drainage may be utilized to a much greater degree than is customary when the natural drainage is insufficient, and a liberal use of cobble-stone or gravel in the yards adds so much to the comfort of the animals as well as of the owner that it is surprising that in locations where either can be obtained at a reasonable expense they are so sparingly used. Nothing is more disgusting to the farmer's family, if they have any refinement about them, than a muddy, filthy barnyard; and the farmer's son who has been compelled throughout all his boyhood to wade through one of these disgraceful, stinking, wasteful cesspools is justified in his desire to leave the farm forever upon the first opportunity. Make the farm and all of its belongings attractive, if from no other motive than that of inspiring a love and respect for the farmer's calling in the minds of the boys who are born and brought up upon the farm. And nothing will go further toward accomplishing this object than so constructing the barns and yards that they and their surroundings may be easily and economically kept clean and comfortable. It should never be forgotten that wet, muddy barnyards, and damp floors go far toward neutralizing all the advantages obtained by what would otherwise be comfortable and profitable shelter. It is a consideration of no small importance in this connection, that from every point of view a system of barn building and management that provides for the frequent if not daily removal of all manure from the barns to the fields is by far the most economical and profitable. And by following this practice what will otherwise become a nuisance about the barnyard becomes a

car 27m

source of revenue when removed to the field. The system of allowing the manure to lay in heaps about the barnyard is not only disgusting and filthy but it is wasteful and extravagant. The barn should be so constructed that the manure may be at one handling loaded into the cart or wagon and taken thence directly to the field; or at most nothing more inconvenient than a wheelbarrow should necessarily intervene between the manure where it is dropped and the cart or wagon that is to carry it in order to accomplish this. When this system of immediate removal is considered impracticable or undesirable the manure may be removed from the barn by the wheelbarrow or cart and neatly stacked or penned up at a convenient point outside to be hauled off at leisure; but as before remarked in substance, both economy and comfort demand that there should be at least a weekly carting of the manure to the fields or pastures where it is needed. The maxim: "Time is money," is no more true and important to the farmer than that "manure is money," and the importance of saving both time and manure is seldom appreciated by the farmer in the construction and management of his barns.

The question of a good supply of water is one that must not be overlooked. Where a reliable and abundant supply can be surely obtained by the sinking of wells to a reasonable depth, this will probably be found the most satisfactory and the cheapest; but if there is the least particle of doubt as to the abundance and permanence of the supply from this source, cisterns had better be depended upon from the first. The annual rainfall throughout the grain and grass-growing regions is sufficiently large as it falls upon the roof of the ordinary barn to furnish an abundant supply, provided it be carefully caught and conducted to well-built cisterns of sufficient capacity; and in either case the windmill will probably be found the cheapest and most economical means of pumping.

As will be seen in many of the plans herein presented, the idea of the old-fashioned great barn, with its heavy timbers and complex frame work, has been generally abandoned by the progressive practical farmers of the Western States, and a

system which, while certainly much cheaper, affords much greater room for the storage of hay and other coarse foods, and admits of much better ventilation and lighting in proportion to space inclosed and money expended, has been adopted in its stead; the central portions being used mainly for storage of foods and the sides for the farm stock. Several barns constructed upon this general idea will be found in this volume, more especially in that portion devoted to cattle barns.

But the whole subject in its every aspect is so thoroughly reviewed in the suggestions, hints, and descriptions accompanying the various plans herein given that a fuller discussion in this connection can scarcely be profitable, and we may well dismiss it here without further comment.

MISSOURI COLLEGE BARN.

The accompanying plan is the work of Prof. J. W. Sanborn, for many years actively connected with the Missouri Agricultural College. Some two years after the structure was built it was destroyed by fire, supposed to have been the work of an incendiary. Prof. Sanborn writes of it as follows:

The barn was located near the farm house, the yard being on the side opposite from the house. This was the source of some criticism, as all barns that may be fairly so named in this region are located quite distant from the house. The purpose in locating it near the house (about 110 ft. away) was that of concentration of work, as the barn was designed to cover everything on the farm that was supposed to need shelter not covered by the house. In passing I may say that no evil effects in odors or otherwise were discovered as a result of this arrangement, while its convenience was a matter of daily gratification and pleasure.

There is also a feeling with our people of Missouri, which I have no doubt is a quite common one elsewhere, that a concentration of buildings involves great fire risks, and so there is a disposition to scatter them. The buildings on the Missouri College farm went to the extreme of concentration, except that the barn was not linked to the house, as one

often sees in the Eastern States. Two buildings only were contemplated for the whole farm use outside of the laborers' cottages. The farm-house included a dairy and ice-house. The barn, as will be seen, covered every purpose that the house did not—for which buildings are ordinarily erected on a farm—tools of all sorts, all classes of stock, and all classes of stock foods, carriages, root-cellar, silo, etc.

The conceded merits of the system—great concentration of labor and saving of time—it was believed would far outweigh the increased fire risk. To this is to be added the saving of cost in construction and repair, as it is well known the larger the space covered the less outside surface of roof and sides has to be provided per foot of space enclosed. Whether scattered or concentrated, however, buildings are usually insured; and the cost of insurance is so comparatively slight as to induce one to accept its protection and then go forward on a line of economy that is formed without reference to risks involved by fire. The annual saving of labor in the barn in question in practice, I believe, is worth many times over the fire risk involved.

The barn was located at the head of what is known here as a 'draw,' which looked to the scuth. It gave an admirable opportunity for a dry and light basement and for ease of access to the first floor, while the yards received the sun's rays, concentrated from the south in the yard, where in winter days it was a most comfortable place for daily exercise when the sun was shining.

The first cut on the following page shows the barn with the end facing the west, the yards being on the south of it. As it was especially designed with a view to the saving of steps by the arrangement of each part with reference to the other, and of manual labor by the use of horse power, steam power and gravity, I will go over each part in detail.

Beginning at the west end (first cut) where the opening is shown in the end of the barn, I will state that this opening was for the reception of the carts and wagons for farm work. The grade in front tipped toward the barn at this point for about twenty feet away in order that the wagons might be easily backed in either by horse or hand power. The floor,

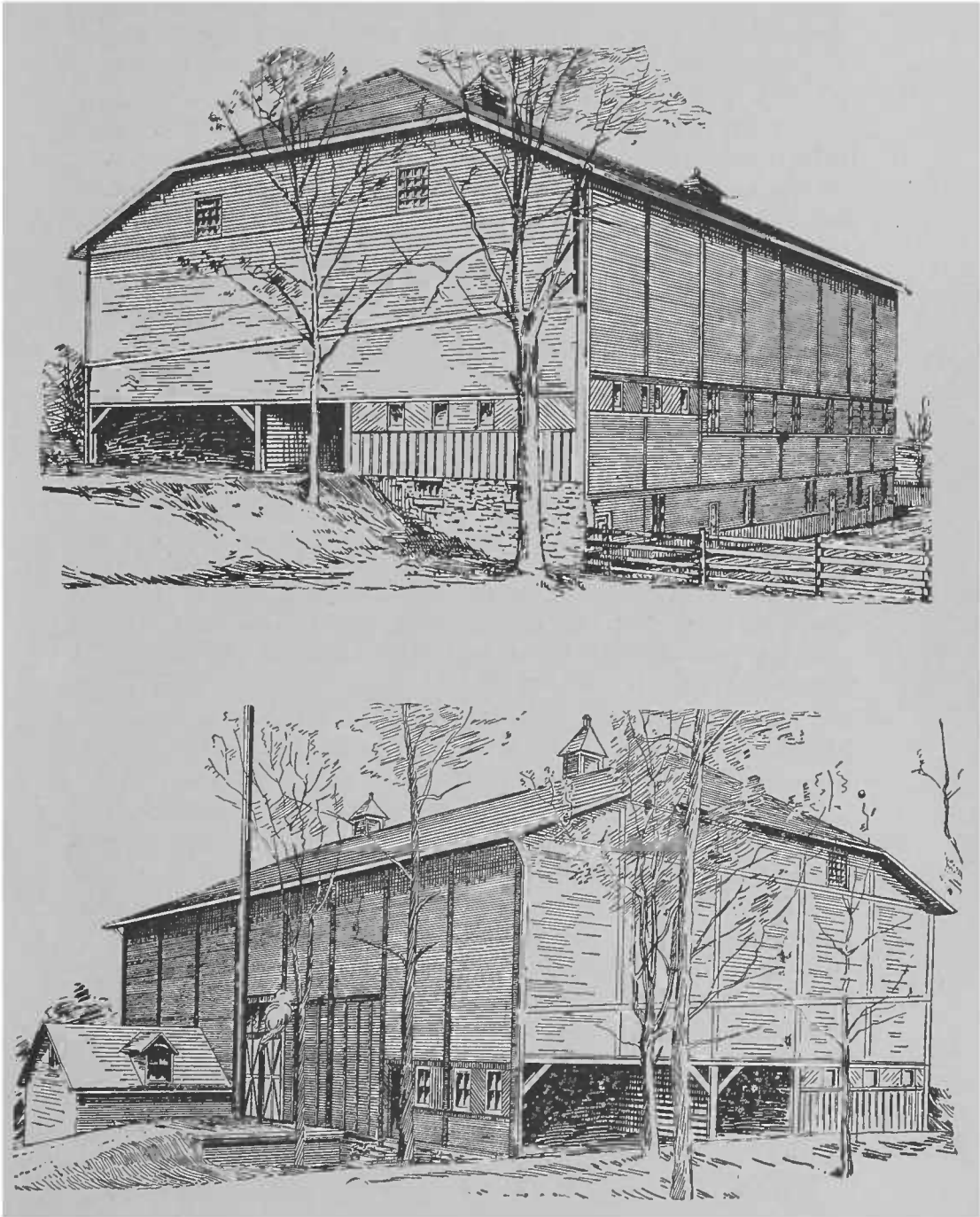

which was laid in tar, protected it from any driving rains that might beat in, although the unnecessary nuisance of run doors was contemplated. Pulleys drew the wagon beds off easily, by the aid of one man, where they were left to hang suspended to the floor of the loft above, and out of the rain, ready to be dropped upon a wagon when required. This wagon shed was located, as a subsequent cut will show, at a point which the horses had to pass in going to and coming from their stalls, so that it was about as easy to house the wagons as to leave them out of doors.

The yards show on the south side. The central ventilating shaft was not completed at the time the photograph of the barn was taken, and the fine appearance of the structure is not well brought out by the cuts. I have omitted to state that its size was 65x130 ft. After studying other forms of barns I could find no form that I believed enclosed the space desired so cheaply and arranged the conveniences so satisfactorily.

The second cut on the preceding page gives a north and westerly view. On the north side is shown, looking from the west end, first the engine-house set in the bank and opening into the cellar; second (and between the engine-house and silo, the silo being the little building with an ordinary roof), is the root-cellar. The roof of both the engine-house and root-cellar is flat or sloped on a gentle grade from the barn, forming the incline over which the crops are taken in at the doors as seen in the center of the main barn (page 15). Once in the barn the teams can be driven around and out at the west end or be backed out and turned on the flat roof. In the roof of the root-cellar is a trap-door down which whole loads of roots may be dumped from the two-horse dump cart used on the farm. The silo is incorrectly shown; a door runs fully down to the roof of the root-cellar, where a window is shown in the roof of the silo. The cutter was set at this door and the cut food fell into the silo by gravity, no carrier being used. The shutter-like work seen on the outside of the barn over the engine-house (page 17) is the exterior part of the corn-crib.

The water supply was taken from the roof of the barn

into cisterns 16x18 ft. It was found that the roof would carry water enough for all of the stock that the barn would hold; that is about 100 head each of cattle, sheep, and hogs, and

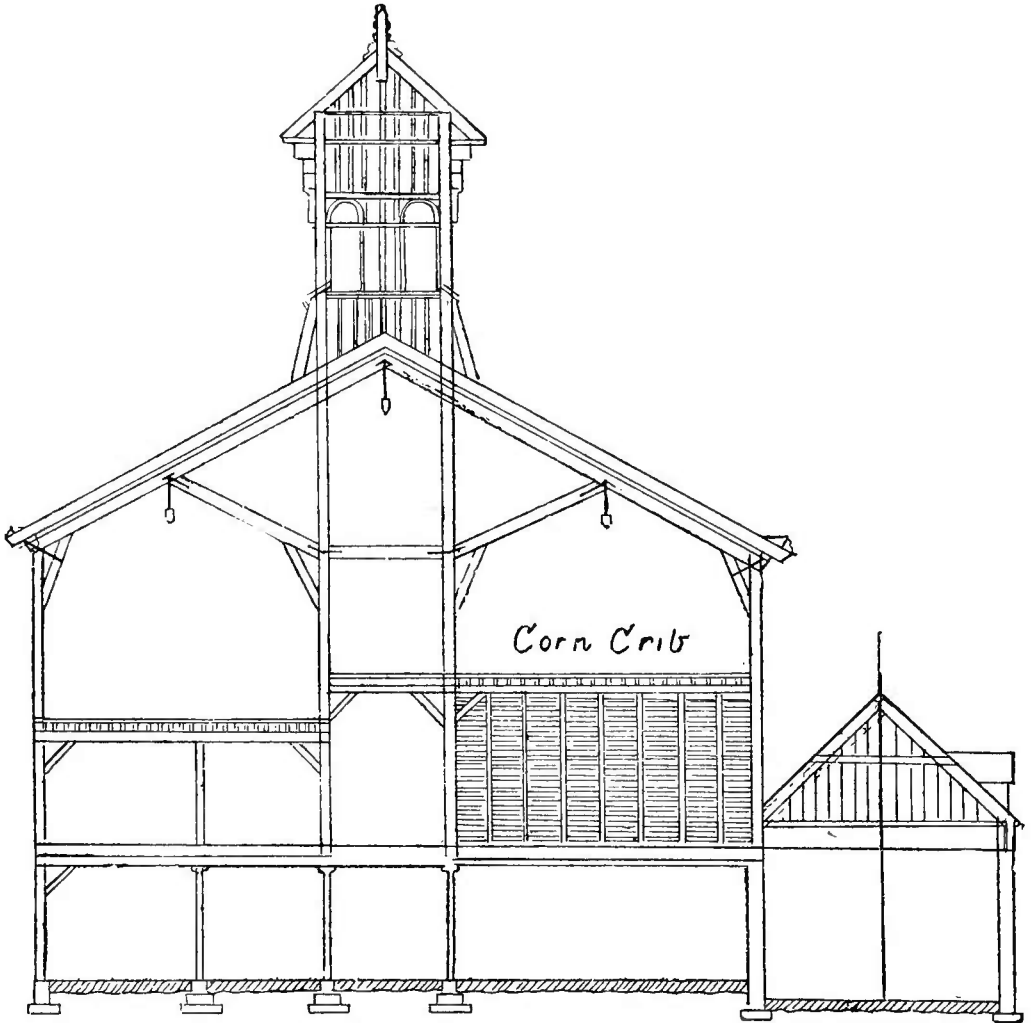

the few horses needed. This water was to be pumped up into a tank holding a week's supply for the stock and located on the second floor, from which point it could flow wherever needed. This water could be pumped up at practically no cost by the steam power while cutting fodder, grinding food,

etc., while at the same time the chill could be taken off the water if need be, by the engine for the entire mass, at practically no cost as it was pumped into the tanks. Two other methods of securing water were open to us; one by boring deeply (for the barn was on the highest point of land), but this would probably cost about as much as the cisterns; and the other was by the use of the hydraulic ram pushing water up from two rather uncertain springs below.

Stockmen who are in a region of doubtful water supply will find that the roof of a good-sized barn will collect an enormous amount of water in the course of the year, provision being made to store the spring, summer, and fall supply. Cisterns for the stock mentioned would cost here about \$650, and four of the size mentioned would be required for the size of barn given, and for our rainfall.

The cut shown on page 17 represents a cross section of the barn and shows something of the method of framing and supporting the roof of a wide barn, which must necessarily be a heavy one. It is particularly given to show the method of framing with reference to carrying the hay by the fork at three points, thus making the work of mowing away as light as possible, for the amount of hay taken away on one track in so wide a barn would make the work of moving it by hand very severe. This cut shows one side of the loft to be deeper than the other. This, however, is only for the section over the granary.

The cut on the following page represents the basement. This is ten feet high on an average—one side being nine and one-half feet and the other ten and one-half feet. This incline in the floor of the basement of one foot from side to side was for the purpose of drainage of the liquid manure, which it was intended to have pass off by glazed pipes to the manure cellar outside, at the southeast corner on the east corner of the building.

A general view of the basement will show that a central walk connected all the feed mangers with the scales, meal-room, silo, root-cellar, water trough, etc. At the same time it will be seen that every animal in the barn could be driven direct to the scales for weight by one person. The gates

Ground Plan
of Basement

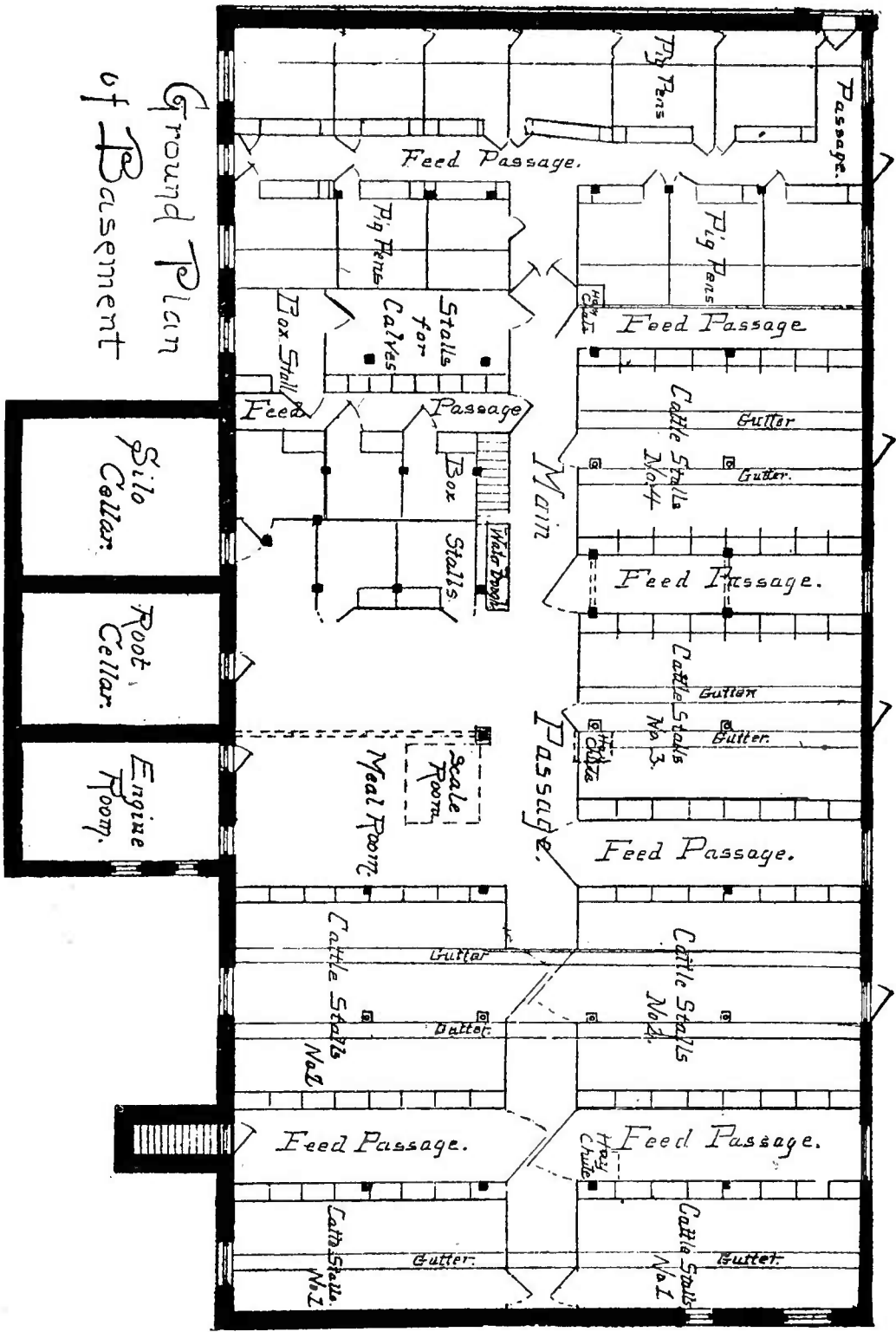

shown are so hung as to make a continuous passage to the yard from the stalls, or a continuous passage from the stalls to the scales. This plan of a passage through the center of the stalls will not strike some as being as convenient as a passage around the walls. The system was employed by me because of the constant use made of the scales in experiment work, as it gave much more direct communication with them. As a matter of economy it necessitates less waste room than the other plan and was found to work very nicely in practice.

The troughs for water in the yard were preferably used for watering as daily sunning and airing was given, except in bad weather when the water in the basement could be used. From the tank above the water could be furnished by any one of a dozen ways. The trough in question supplied a ready source of water for pigs, etc.

Tramway lines, which are cheaply made, were to run from silo, root-cellar, and meal-room; also from the water-tight gutters behind the cattle to the manure vault, so that the manure could be run off daily to the manure cellar—a building under a separate roof. This manure shed was also to be liquid tight, so that no liquid manure (which is about one-half of the value of the solid) was to be lost, either from the cattle stalls or from the manure shed. To prevent this loss in the cattle stalls the gutter behind them was laid in pitch where wood was used. A part of the cattle stood over cement floors—both systems being used as an experiment. The cement floors gave me satisfaction; they were possibly more slippery, but for the young cattle they were not objectionable to a degree to enter materially into the calculation. Their cost was somewhat more than wood, but their durability is far greater when well done.

A half dozen systems of tying up cattle were used; each was liked for its place. The system for which I am without a name, but which consists of a half circle from which a chain comes up under the throat of a cow and around her neck was one of liberty, economy of food from waste, and cleanliness of the cows. The box-stalls show their purpose.

The hog department was separated from the cattle sec-

tion by a close partition. Here hogs could be winter-fattened fully as cheaply as under summer heat, and at a time when pork would bring its best price, while for feeding and for experiment work they were directly accessible from scales, meal-room, water, etc., requiring no duplication nor change of place to feed at a loss of time.

The meal-room, by the scales, had all of its grain spouted down from the granary above by merely drawing a slide. The meal could run directly into the feed-car in the square in front of the root-cellar and engine-house, where the root-pulper and steam-box were located. It will be seen that the roots which come down by gravity from above pass out on a level floor to the pulper and in the direction needed.

The fodder for the stock comes down the three large ventilating tubes. In the loft these tubes have a series of doors one above the other, so that, however full the loft, fodder could be pitched into it easily. Pure air is an indispensable requisite of stock quarters. To procure this these three ventilating shafts were inadequate, hence all around the sides of the barn numerous others were provided very cheaply by nailing boards on the studding until the eaves were reached, under which an opening lets out the ascending current. The base of all of these many ventilators could be opened and closed at pleasure in cold or warm weather. It is needless to say that with double windows such a basement would not freeze in winter and would be cool in summer.

I suppose the reader will understand that the feed passages are entered from the main passage and that two rows of cattle are fed from one feed passage. In experiment work the fodder was weighed up in bags and each animal's food placed in the feed passage before its manger.

The cut on page 22 represents the second floor, to which easy access is had from the ground. On the west end the open wagon-room is seen, and by its side, separated only by the passageway, were the horse stalls. These stalls were neatly made and so formed that no food could be pulled out under foot. Behind them was an open square for currying, and around the side not occupied by stalls a harness closet and also places for every stable convenience.

FIRST STORY

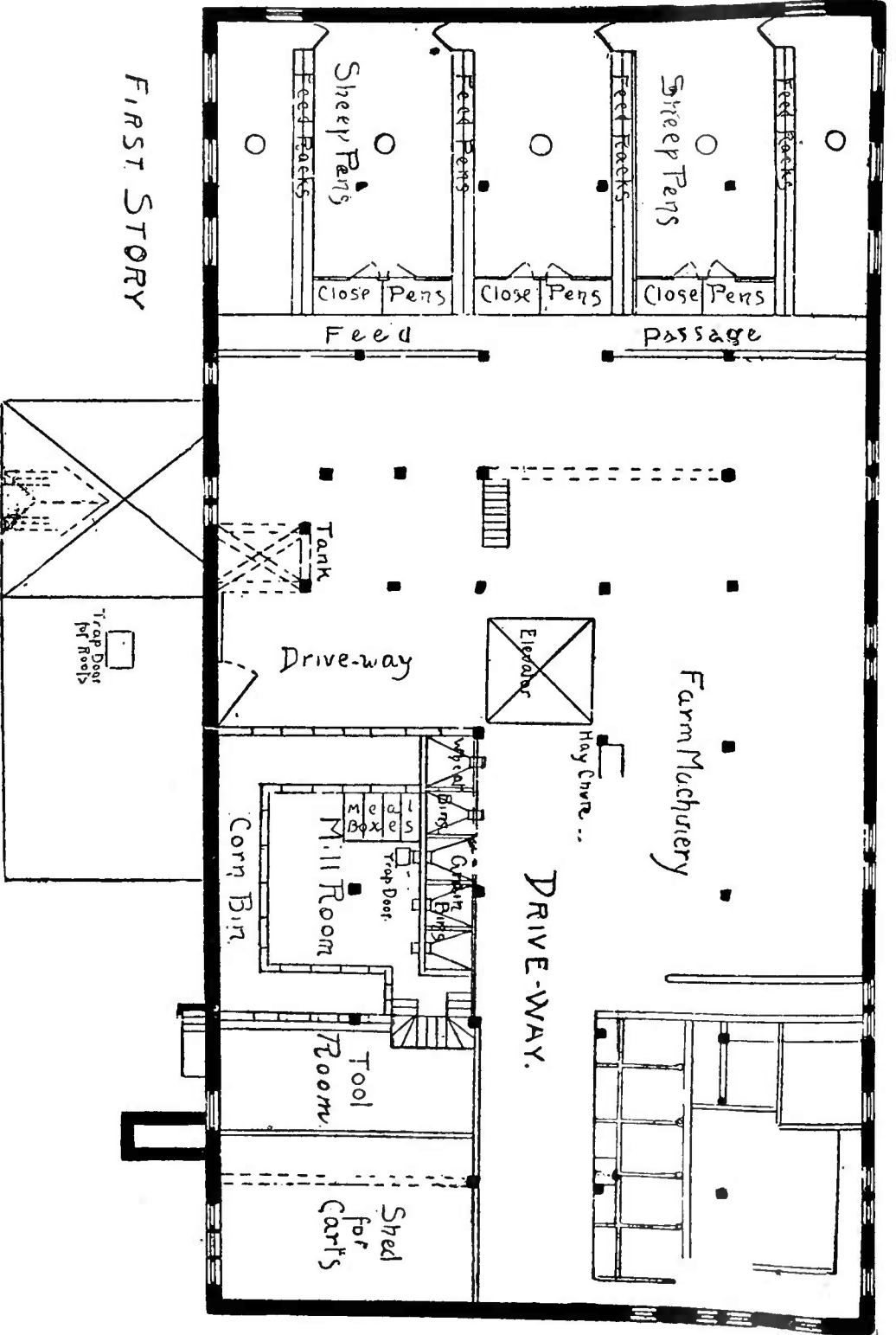

Hay Loft Floor Plan.

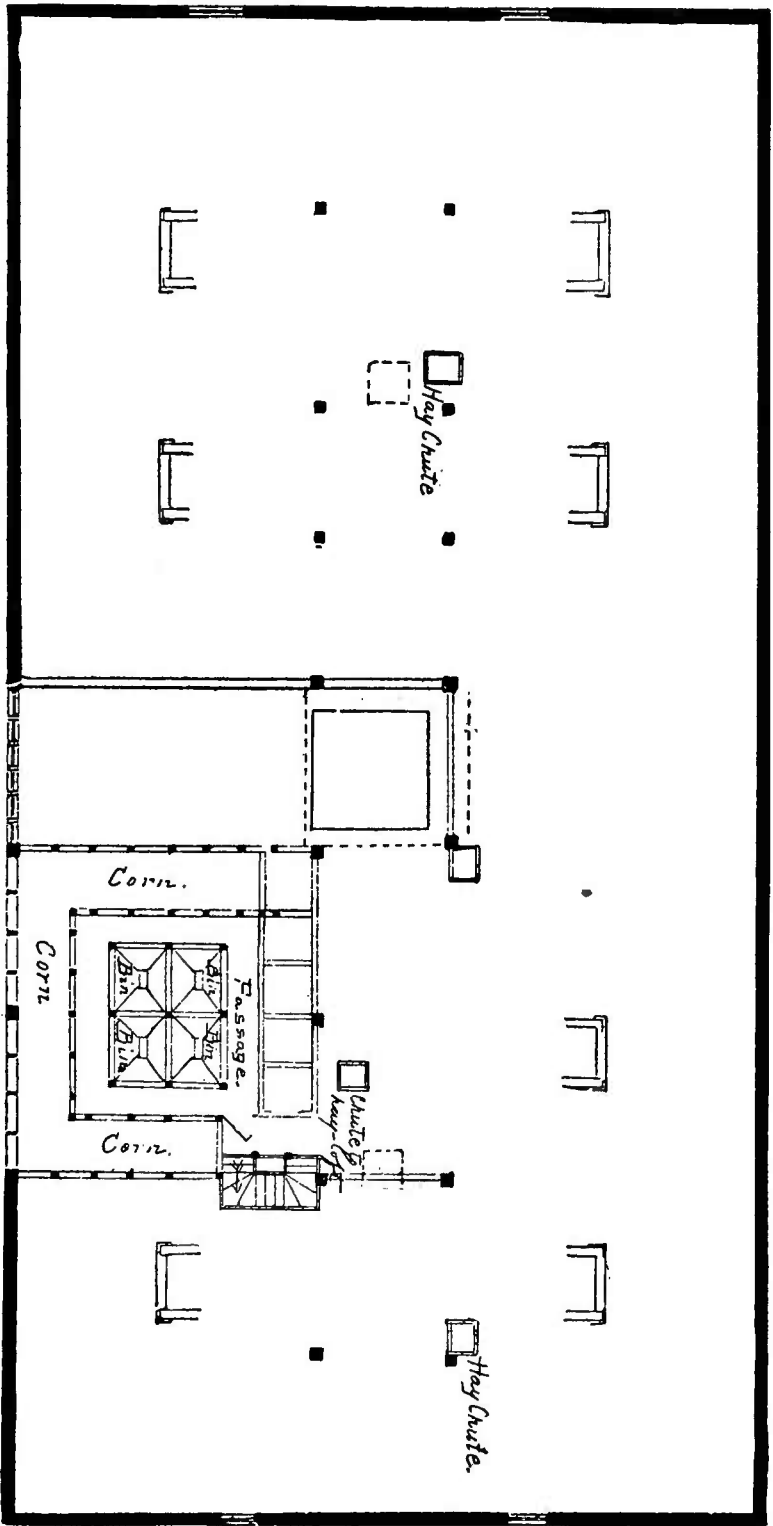

The small tool-room was ceiled up by itself and contained every small tool needed on a farm, including assortments of bolts, nails, screws, etc. Upon its walls every tool was painted that would admit of being hung up; and every one was required to put the tools in the places thus mapped out for them. It is a most successful and gratifying plan, saving perennial hunting for tools, and at night one could put his hands on any tool needed. A broken or lost tool would at once be missed on the most casual survey of the room; also a dirty one could at once be traced home to the party last using it. Where several laborers are employed this is indispensable, and it is a great convenience if no one is hired. The proximity of this room to the large farm implements was equally convenient. It was easy and encouraging to make repairs on them and convenient in bad weather to do it. This room was 30x70 ft., including a section for carriages. A general catch-all room for lumber, boxes, etc., of 27x30 ft., including room for the tank, will be seen on the plan where the tank is marked.

The sheep barn occupies the east end of the barn (page 22) and provides room for 100 sheep. The hay for these sheep and also for the horses is dropped in front of both sheep pens and horse stalls by a cut-off door inserted in the ventilating shafts. These doors are operated in the loft by either ropes or rods. The sheep are fed by entering the open end of the rack from the main floor. Turning doors act as cut-offs to the sheep from eating hay while grain is being fed and when swung at the right angle as racks, from whose small opening left unclosed by the two—one from each side of the rack—the sheep pull the hay as needed, any dropping passing into the receptacle below. By this plan no hay seeds get into the wool of the neck. This rack I first saw on the farm of the late Col. John B. Mead of Vermont. The yards are on the east end and not shown in the plan.

All fodder drawn into the barn passed over scales set in the floor in the driveway and not shown in the plan. The central point from which the fodder was drawn into the loft above is shown.

The grain room was believed to be a model of conven-

ience and difficult to improve upon when all points are considered. The cribs were four and five feet wide for corn and fourteen feet deep. This narrow width was for the purpose of securing ample ventilation, thus enabling us to put the corn in early, as I have always advised. To further secure this end the cribs were slatted up—the outside section being put up like shutters in order to keep out rain. The inside was nailed up in a plain way with slats with spaces for air to pass, except that at all needed and convenient points the slats were set at an angle and dropped into slots from the outside of the crib. These could be taken out and put back at will even when full of corn, so that we could get the corn out or put it in from any point of the crib.

The grain bins shown were also fourteen feet tall and their tops stood by the side of the thresher on the upper floor. As the grain ran from the thresher it could very largely drop into the bins without being touched. From the bottom of these bins arrangements were made to spout it out. In the square formed by the grain and corn bins the grinder and sheller were set. The ground grain was put in boxes whose bottom centered at a spout from which it could be drawn out below for the stock.

The method of getting the corn to the bin was, so far as I know, an original one. Four boxes were set in a wagon bed into which the corn was thrown as it was husked out. These boxes would hold as much as a wagon bed with the extension on. On the sides of each wires were placed, which with a bail dropped from a hay-carrier placed over the bins formed a swivel. The boxes were drawn up by horses and carried by them over the bins on the track. When at the right point the man below, holding a rope attached to the box, pulled the rope, tipped the boxes bottom side up and emptied their contents upon an inclined plane which shed the corn off into the bin. Of course the corn-bin was covered by a roof to protect it from the hay. This plan worked admirably.

The cut on page 23 shows the loft. It needs no explanation. The ventilating shafts, place for threshing, etc., etc., are all shown. All foods are drawn into it—corn-fodder,

grain, etc. The grain is threshed at leisure in dull or winter weather. The loft of the barn would have held about 400 tons when pressed to its full capacity. Three hundred and fifty tons could be put in without encroaching upon the room used in the sweep of the central hay-carrier fork. This room was usually filled from the farm of 118 acres.

MR. S. J. HARRISON'S BARN, LANARK, ILL.

This barn is described by Mr. Harrison as follows: It is 86 ft. long, 44 ft. wide, 20-ft. posts, 18-in. cornice, requiring 43,000 *A* shingles, 37,213 ft. of lumber, sided with A ship-lap. There are two cupolas and forty windows. The cost at prices prevailing here (1882) may be estimated as follows: Lumber, \$753.42; carpenter work, \$300; masonry, \$60; painting (lead and oil), two coats, \$75; hardware, \$40. Total, \$1,228.42. Its capacity is 94,600 cubic feet; corn-crib, about 680 bushels in ear; granaries (five bins), 2,100 bushels; mow for hay, 59,824 cubic feet (allowing 512 cubic feet for a ton), 110 tons. Buggy-room has space for two vehicles. Main driveway at rear of horses, room for four two-horse wagons. Nine box-stalls, each large enough for two horses if tied; and, as indicated on ground plan, room for forty-five head of young cattle.

The convenient points attained may be summarized as follows: Buggies and wagons just behind horses—no mud to go through to get horses to and from them. Vehicles can be drawn into shelter before unhitching. All the stock kept in barn can be watered without going outside the building. Grain equal distance from each end of feed-alley, and hay dropped from mow nearest possible to place of feeding. Driveways so that all manure is pitched on wagon and hauled and spread on fields where wanted. This saves much labor and loss of strength in manure; keeps the premises neater, cleaner, and healthier than when piled up outside of barn. For the purpose intended this barn combines capacity, convenience, and economy better than any the writer has yet seen. By economy I do not mean something

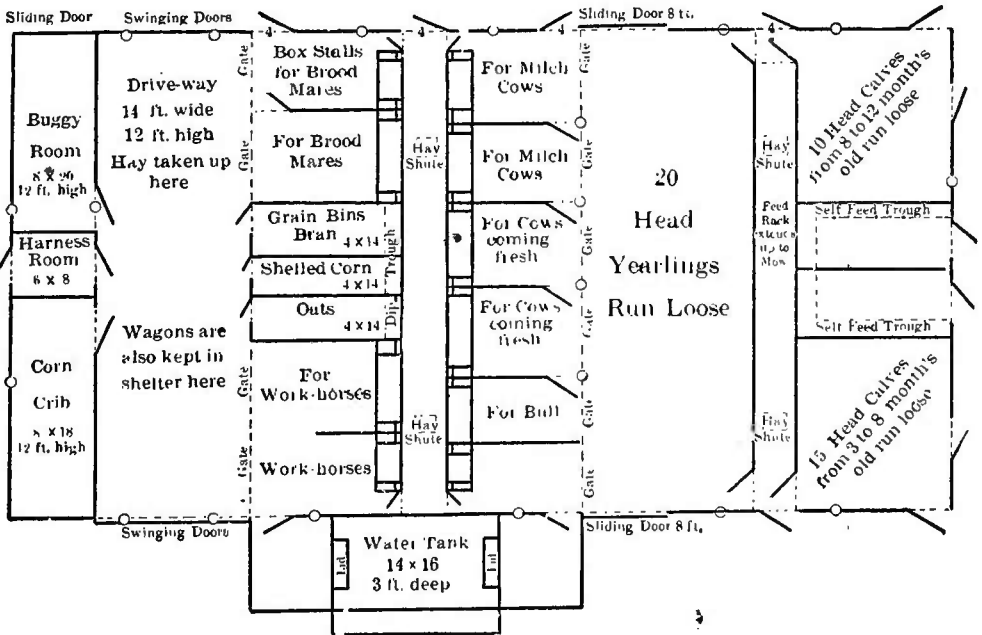
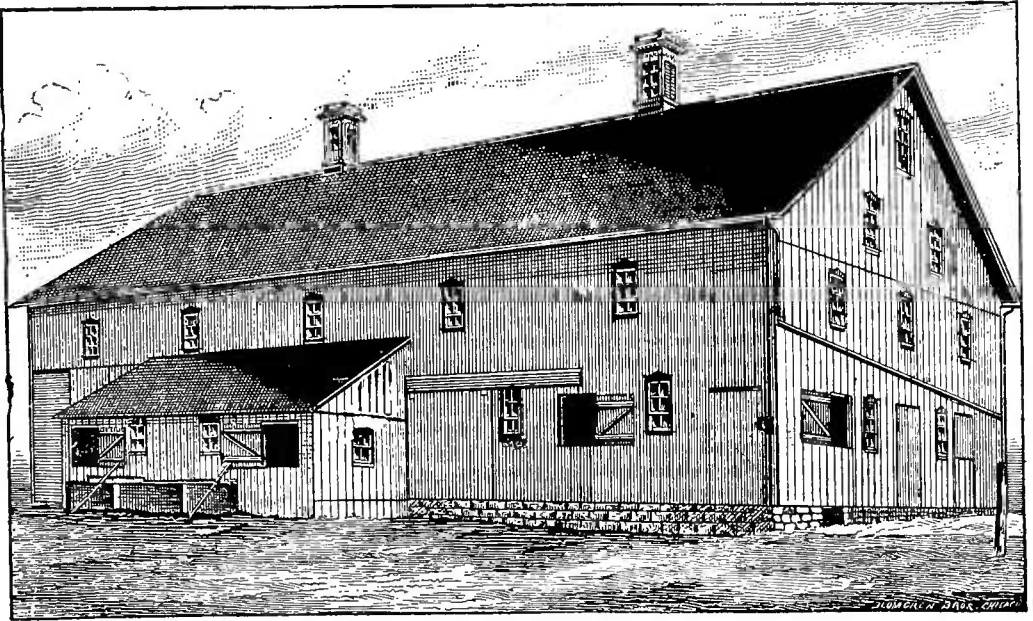

cheap and temporary. My experience is that everything temporary is expensive. In building, therefore, I did not regard present cost so much as durability. Ground barns usually give way first in the sills. I therefore have no sills across the barn, nor at the doors, to rot out, but the posts rest on large rocks selected for that purpose. There are no floors except in feed-alleys, granaries, and in the stalls for horses and milch cows. The floors in the stalls consist of two-inch plank laid flat on the ground. Plank on the ground will last as long if not longer, when stock is kept on them, than if laid on joists, and as a foundation for the plank ground in this country is cheaper than lumber and is more enduring. The outside sills rest on a wall about two feet high and the barn is filled up with dirt to the top of the wall. This makes the barn drain readily. A couple of loads of dirt occasionally brought in keeps the floor in good order.

[Our drawing of the elevation fails to show the ground leading up to the sliding door *properly graded* to permit of driving teams into the barn.]

MR. R. F. AYRES' BARN, LOUISIANA, MO.

This barn is described by Mr. Ayres as follows: It is the most convenient barn I have ever seen. It accommodates ten horses, twenty cows, and twenty-five calves, with ample room for each. The stock, as you will see, are all in the basement. The basement walls are of solid masonry, 8 ft. high: the second story is frame, 14 feet to the square of the building, floored with 2-inch oak for driveway and 1½-inch oak for balance of barn. Can drive loaded wagon anywhere over barn floor. Have no loft above; have abundant room for hay to supply stock for one year. Office, corn-crib, and bins being 10 ft. high, leaves 4 ft. under the eaves; this, running out half-way over the driveway, with a tight floor, is used for storing sheaf oats. The rafter support is something new "under the sun," so my carpenters tell me. I planned the whole thing, from top to bottom. There are three posts, 6x6 14 ft. high, running through the center

the long way; on the top of these is a center beam same size as post; upon this are set dovetailed struts in the shape of the letter V, 12 feet apart, in pairs; and on top of these the "purline plates." This makes a very simple frame for roof, and does away with the network of timber usually found in the haymow of barns. The dotted lines between driveway and haymow and "farm implements" and haymow (lower cut on following page) are imaginary lines showing how I

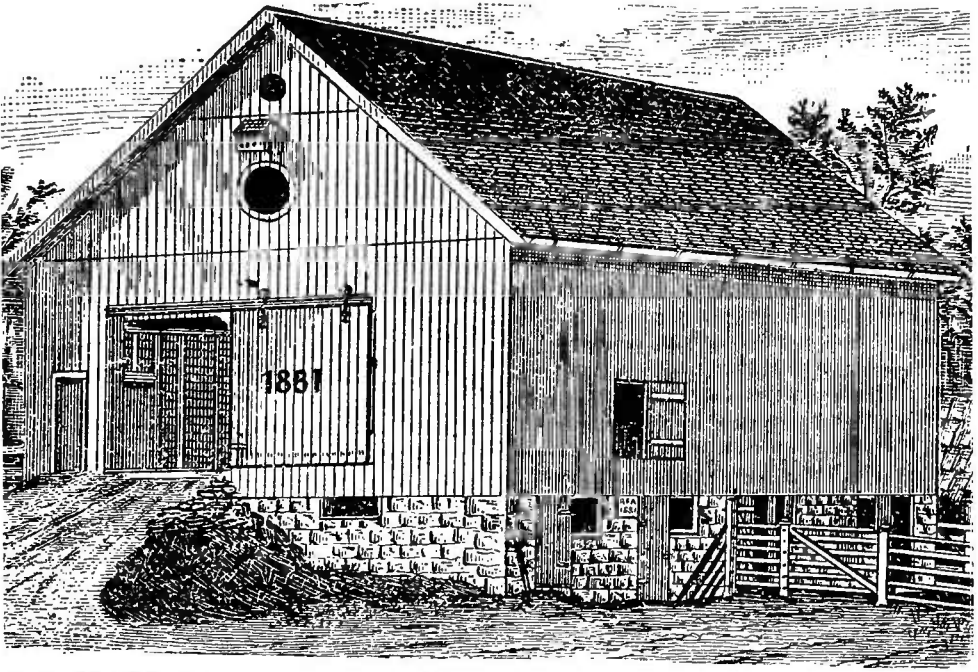

make the divisions in storing away the hay. Can turn with wagon and team around post, coming it at either door.

The north side is five feet under ground, with east and west ends gradually coming to the level of the ground on south side. The stock—horses, cows and calves—are all separated, each going to separate pastures. All the stock stand with heads to halls. This barn can be built at a cost of from \$1,500 to \$2,000, locality and convenience of material to be considered.

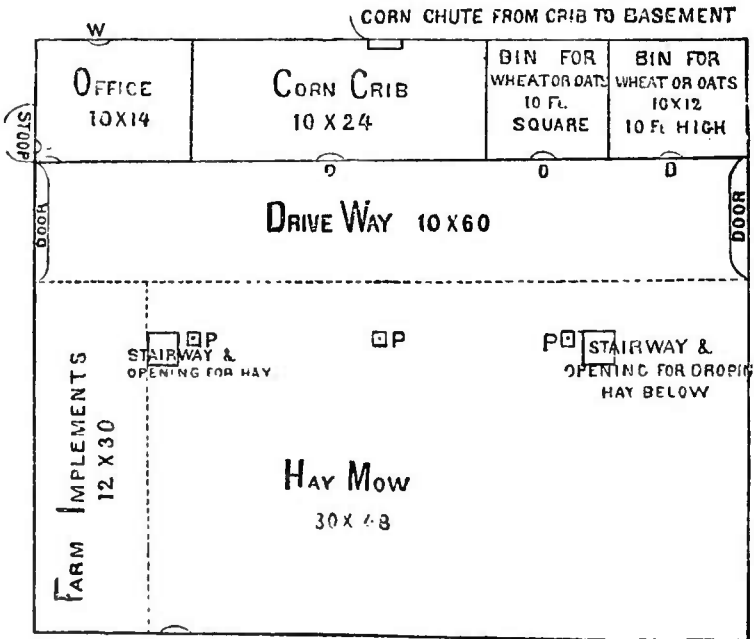
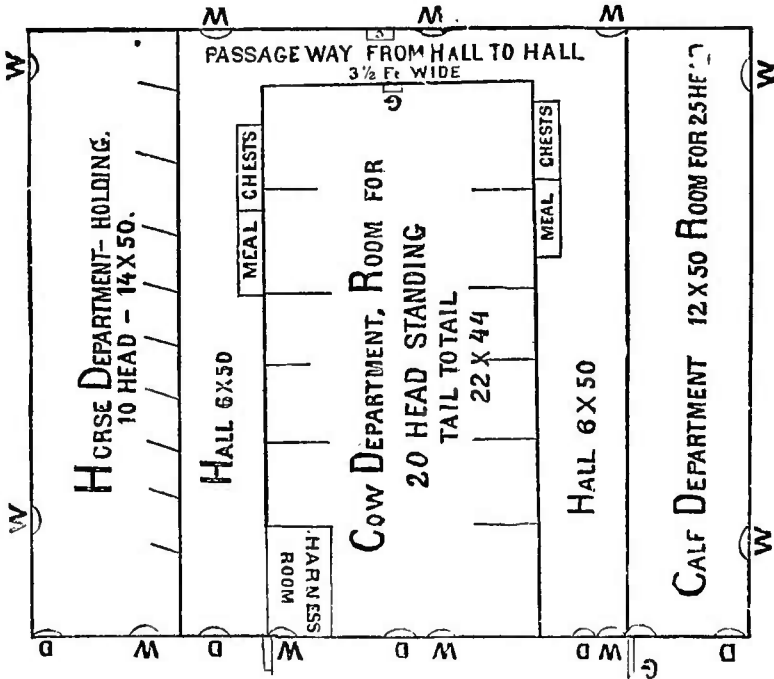

COLDREN & LEE'S BARN, IOWA CITY, IA.

This barn is described by Messrs. Coldren & Lee as follows: The total cost, including paint, etc., was \$2,200. The foundation consists of stone piers under each post 2x2x4 ft. deep. In addition to this Mr. Lee has, with his characteristic attention to details, placed cross-sills laid on extra piers

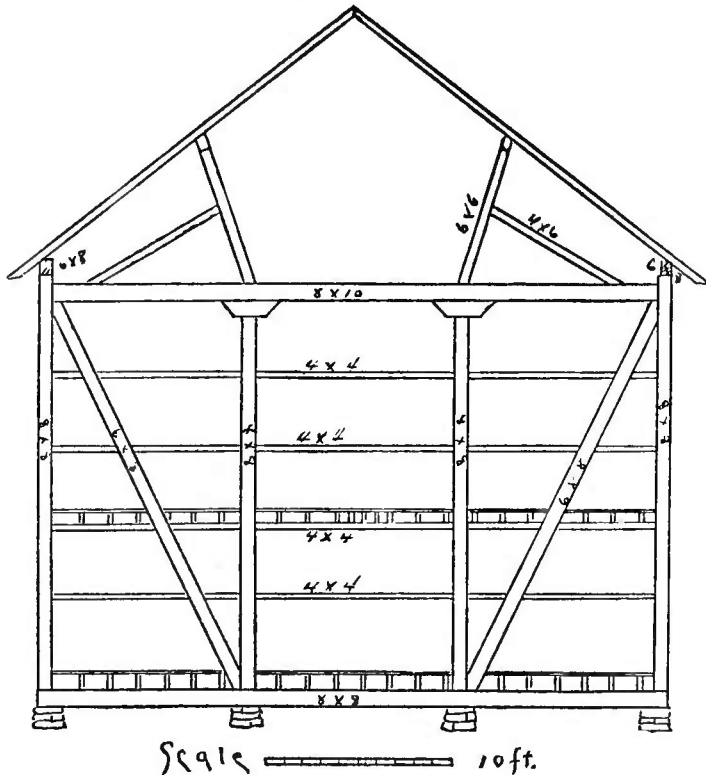

between the several bents. The frame is a mortise-and-tenon structure with this peculiarity, viz.: the usual small 4x4 braces are dispensed with and in their stead long 6x8 pieces are used, as shown in diagram. The same system is used on the sides, and it makes a wonderfully strong and durable frame at probably but slight additional cost over the usual method. Sills and posts are 8x8, the latter 22 ft. 8 in. Plates and braces 6x8. Cross-ties 8x8, except the end plates which are 8x10, to prevent bulging at the ends. Joist, first

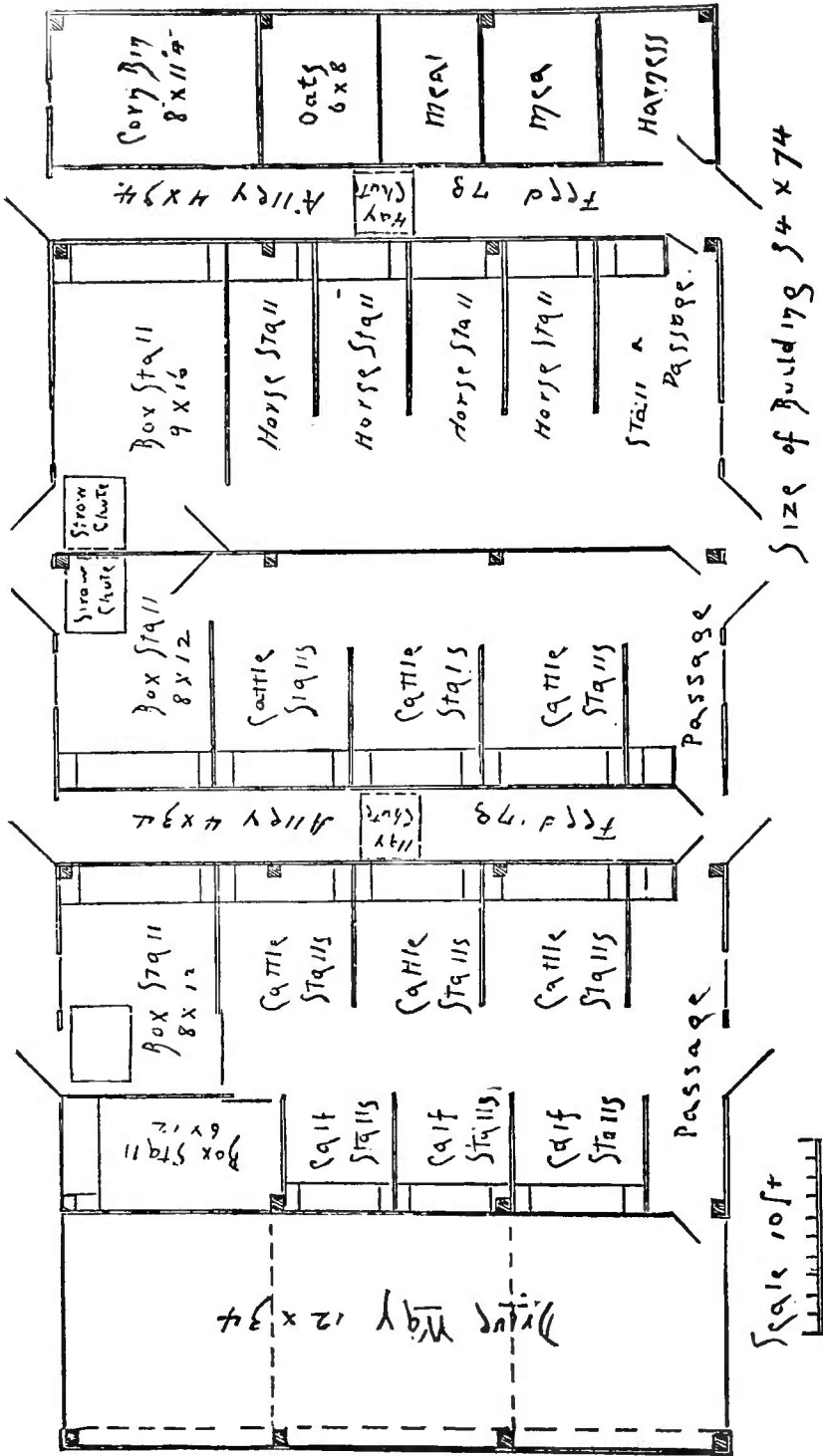

Size of Building 34 x 74



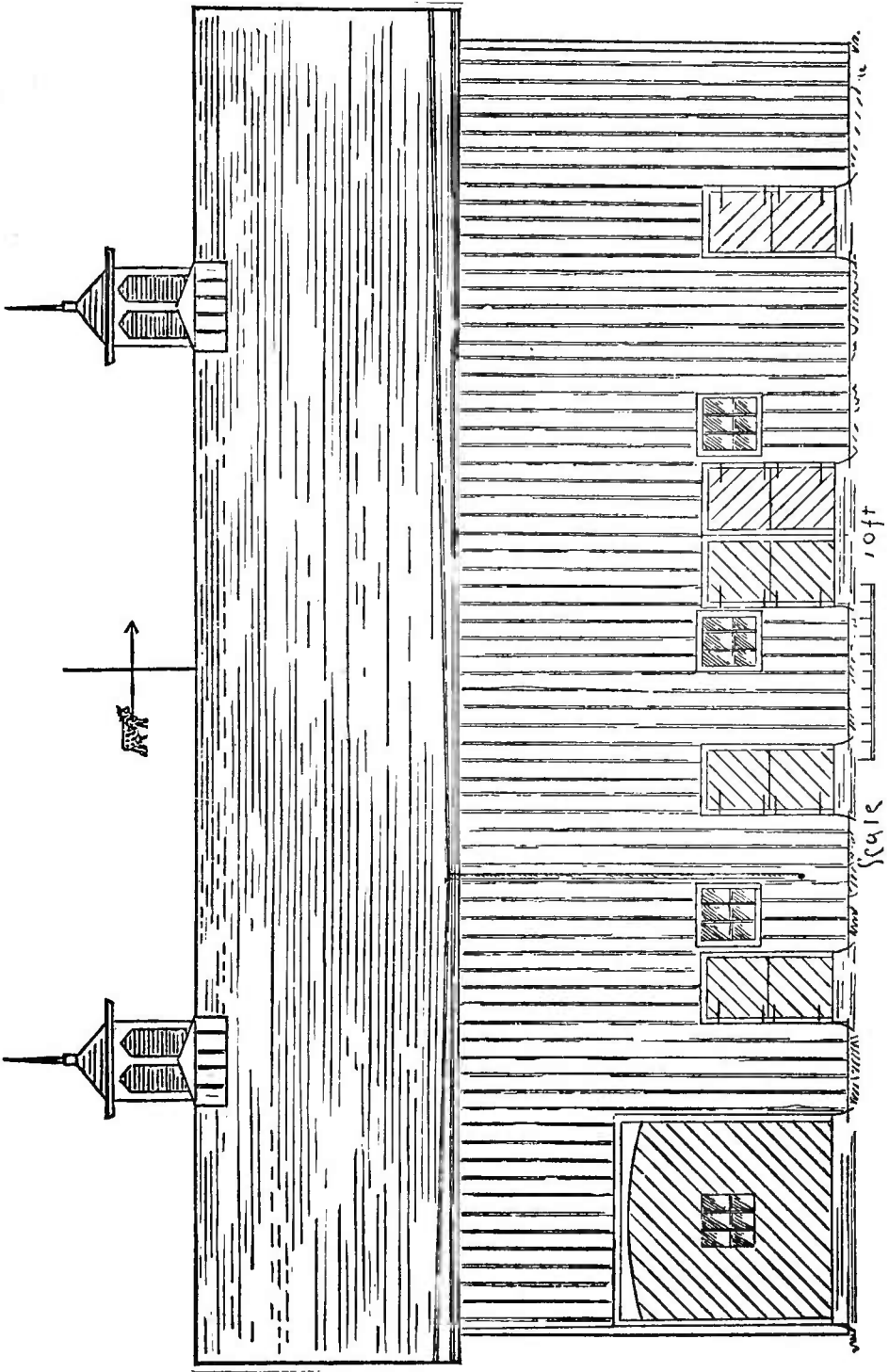

floor, 2x10 18 in. apart. Joist, second floor, 2x8 16 in. apart, with an extra one through the entire center of barn. Floors under stalls, etc., 2 inch laid slanting to rear for drainage. Floors of feedways, etc., 1 inch. Floors of loft 8-in. matched lumber. Rafters 2x6 20 in. apart. Shingles $4\frac{1}{2}$ inches to the weather. Roof elevation—eaves to apex—13 ft. 6 in., something over one-third pitch. Siding 12-in. stock boards with O G battens painted before being put on. The eaves project 20 inches. Windows are 6 lights, 9x14 in. Doors 3 ft. 6 in. by 7 ft. 4 in. The cupolas are well proportioned and very neat, being 4 ft. square and 5 ft. 10 in. from apex of roof to eaves of cupola. The roof is tinned.

The large driveway doors are hung on weights (first make and weigh your door and then procure the requisite weights). They are 12x12 ft. and slide up on the inside. The driveway has a hinged feeding rack and partition gates, and will accommodate a number of calves. The hay is unloaded here through a 12-ft. square chute above. There are two straw doors (not shown in front elevation) on rear elevation to take in straw upon the loft floor on that side, the chutes marked in ground plan serving to bring it to the stables as needed. Altogether it is the plan of perhaps one of the best-arranged and most carefully-built barns.

The following are the items of cost: Carpenters, \$375; paint, \$175; hardware, etc., \$137.50; tin work, \$70; windows, \$10; lumber, etc., \$1,432.50. Total, \$2,200.

FARM AND SHEEP BARN BUILT BY DR. N. D. GADDY, LOVETT, IND.

Dr. Gaddy writes of his barn as follows: The size of the barn is 56x84. The posts are fourteen feet apart each way and stand on stone pillars, which are, at top, a few inches above ground and reach below the surface beyond the freezing point. There are no sills in the barn, unless that which the crib rests on might be so termed. It is high enough above the top of the ground to admit lambs under the crib by going between rollers, or "lamb creeps." Under the edge of the crib is a trough, in which corn, or meal, etc., is

kept for the lambs. After they learn the way under and to the corn, oats, or meal, the noise of the rollers warns the shepherd of the presence of the lambs—come for something to eat.

The divisions are made by fixing girts or stringers from post to post, one near the ground and one three feet above it. To these the refuse ends of planks left in building the barn were used and nailed upright, leaving a space of seven inches between each two upright boards, through which the sheep can put its head and eat without pulling out the hay or fodder and wasting it. By opening or closing gates the apartments may be increased or diminished in size. Instead of nailing or mortising in the girts to the posts I use a portable fence in part of the barn. This portable fence may be double, leaving space constituting a rack for hay. Sheep may eat hay from both sides then if the fences are made so that they can get their heads through, as in the fixed racks. At the east end of the sheep department are eight-foot gates, or two gates four feet each, which, when open, constitute an eight-foot driveway parallel with the carriage driveway in the west end of the barn and parallel with the middle driveway. These three driveways make it convenient to load the manure into the wagon or wagons for removal to the pastures, meadows, or cultivated fields. With plenty of straw for bedding the stock no stable, excepting that for the milch cows, needs daily cleaning. Those who drink milk or use butter will consent that a cow's stable cannot be kept too clean.

With care in bedding horses, where the mangers are high, it is not an absolute necessity to remove the manure from the horses' stable oftener than twice a month, and sometimes we neglect it a month. The manure in the sheep's stable is removed twice annually, but need not be removed more than once a year, if the owner so choose, unless the stone pillars are so low as to allow the accumulated manure to come in contact with the lower ends of the posts.

As we are done looking around on the ground floor; let us ascend the stairway in the west, or carriage driveway. Before starting up, however, you should notice the door fasten-

ings to the large doors at either end of the driveway, and note that the buggy or wagon may be driven in, the horses ungeared, watered at the well here, put in their stalls and fed grain and hay without exposing them again to the storm, if it exists.

As we go up the stairway you will observe that the south end of the driveway, for an extent of 14x14, is not floored above. The same arrangement exists at the north end of this driveway. (This is convenient for unloading hay at this end of the barn.) The remaining 14x28 ft., you observe, is floored tight; or from west to east, 28x42 ft., then an open space over middle driveway of 28x14 ft.; then, again, floored for a space of 28x28. On each side of the last the floor is lowered eighteen inches, and floored 28x14 ft. on each side. As these floors, aggregating a space of 56x28 ft., are over the sheep stables, they are laid very tightly. Over the horses' and cows' stables are floors 11x28 ft. each, on which are built additional granaries. The intervening space of three feet between these and the main floor admits of hay being thrown down into the mangers. Across and above the middle driveway are foot-bridges, one at each side of the main floor, over which let us walk and descend another flight of stairs into the middle driveway. As we approach the large door to go outside, take hold of the lever that hangs on one door and raise it to a horizontal position and you observe that it raises the lower piece that fastens between stones at the bottom, while it lowers the upright piece that goes into a mortise hole in the tie across above the door. Now, push open the door and you observe the door carries the fastening apparatus with it, so that it is always ready for use just when and where you want to use it. I had become tired with the usual troublesome fastening, by means of a movable upright, to shut the two doors against; and about three years ago I devised this, and had my carpenter construct it; and I find it very convenient for double-door fastening, when properly made. This fastens one door, and the other can be fastened to it very easily.

On each side of the sheep department are gates eight feet long, to fasten the sheep in and keep the doors open for ven-

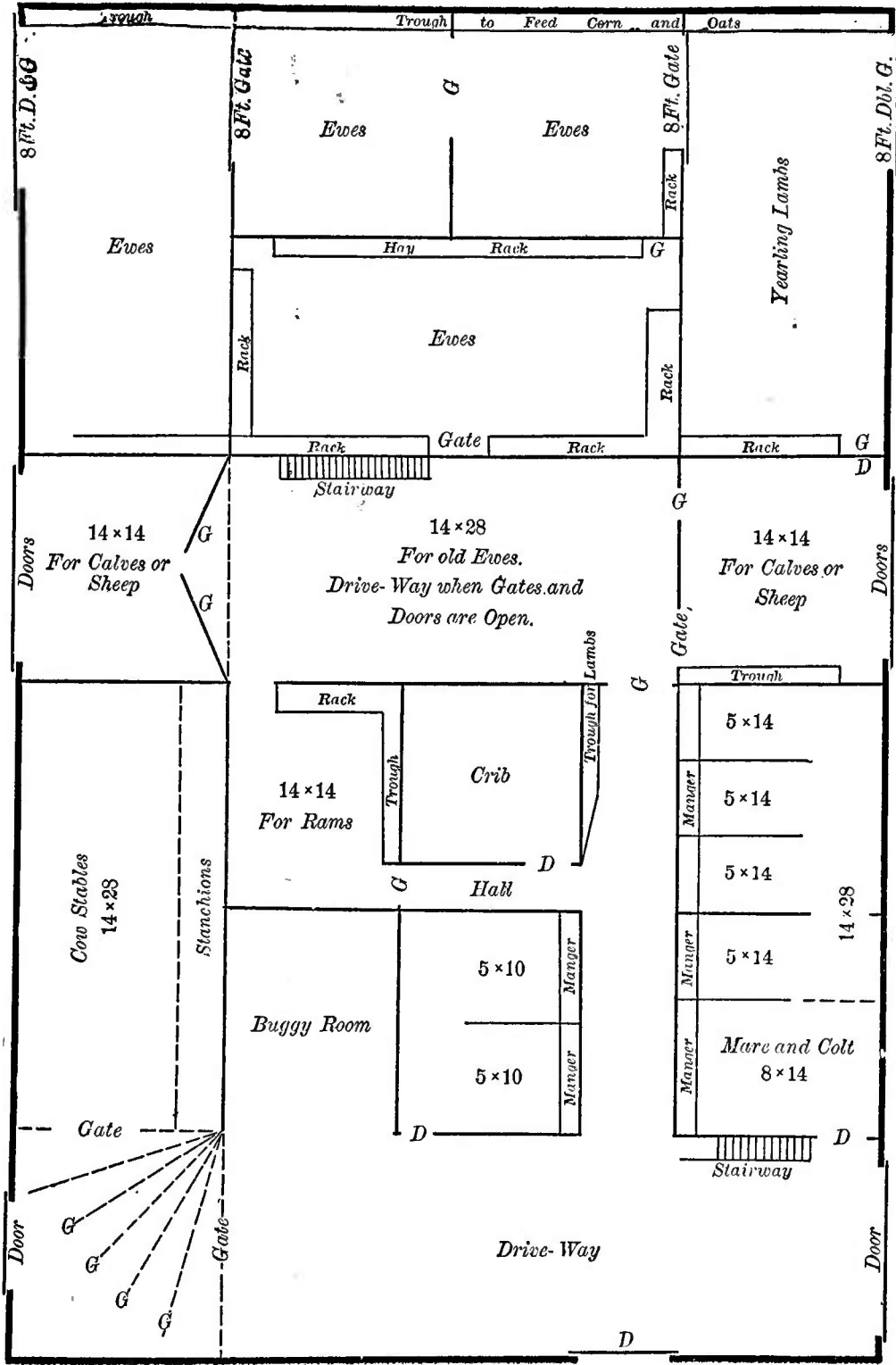

tilation in warm weather. In snowy or stormy weather the doors may be closed. Long, sliding windows are so made in the east end of the barn for the purpose of additional ventilation, as well as for the admission of light.

CATTLE BARNS.

Before entering upon our series of illustrations of cattle barns we may well supplement what was said upon the subject of barn buildings in general by the following from the pen of Col. W. A. Harris, a well-known and experienced cattle-breeder of Linwood, Kan:

The ideal location for the barn should be as nearly as possible in the center of the farm. The dwelling, of course, must be near and, alas for the gossips and the people who "get lonesome," more than a few feet from the county road! The advantage of having as many pastures and fields directly connecting with the barns is immense. Time, distance, labor, all are saved; and oversight, at all seasons, of the stock made more convenient. The character of the site, however, is of still greater importance, and if there is anything worse than a low, flat, undrained barn-yard and adjacent lots the writer has yet to see it. Strange to say, nothing is more common.

If such a location is unavoidable then it will pay to use all the resources of drainage, tile and stone, till even the longest wet spell loses its terrors and planks and rails no longer are needed as bridges to cross the depths and reach the barn door. Wet and not cold is, besides, the greatest enemy to thrift and flesh, and the floors of all sheds and pens must be high, dry, and well drained. We read of covered and paved courts, etc., in England that seem "all too bright and fair" and beyond our fondest hopes, so perhaps we had better go to the barn at once, though do not forget the importance of a sufficient number of well-fenced, conveniently-arranged lots of sizes from a hundred or so square feet up to an acre or two. There are never too many. There is an infinite variety of wants met by an infinite variety of circumstances, mental peculiarities, and financial conditions, resulting in a corresponding variety of farm buildings

to be found scattered over the land, from the huge, ark-like structures that dominate the landscape in Lancaster Co., Pa., to the four forks with a prairie-hay roof that shelters the pony team in Kansas and Nebraska. We are of the West, however, and the great grain crops here grown are not housed "in the straw" as they are there, and our need is greater for the shelter and protection and convenient feeding and care of animal life, hence our talk must be in that direction. First and foremost we must place good air, good light, and dryness; they go together. One of these qualities lacking the others are almost sure to be absent. The dark, cavernous recesses of very large barns are seldom ventilated or dry, and this is almost necessarily a consequence of great size. The heavy foundations imply a basement dark, damp, and stinking. The great roof and floors mean heavy timbers, much skilled labor, and expense, and last but not least is the chance that some winter night, in red and yellow flame skyward soaring, the huge structure vanishes with all the horrors of agonizing death to helpless creatures (we will not say brutes) and to the owner loss immeasurable. Let us rather have two or more smaller buildings, all above ground, on light foundations, light timbers, but little "framing"—the "balloon" style of construction permitting the use of much ordinary labor—far enough apart for some degree of safety from fire and a chance to save life. Doors on every side and ample windows. Nothing is so cheap as sunlight and yet nothing is so scarce in the average barn or stable. Another great advantage of somewhat scattered and smaller buildings is the possibility of dividing up the stock and obtaining direct access from different lots and pastures of different classes of stock. It is not uncommon to see in the middle of the night, in a large barn, a hundred cattle aroused and disturbed by one uneasy heifer or lost calf. Avoid all plank flooring as one of the worst temptations of the artful architect. Broken stone (eight inches) with here and there a three-inch tile running to the outside, with six inches of porous, yellow clay on top, wetted and tamped, hardening like a brick, will always be dry, never slippery, needs only here and there after the

winter is over a little fresh clay and affords no harbor for rats. Have no narrow, contracted passageways for the larger cattle to crowd and jam together in. A favorite arrangement seems to be a narrow feeding alley, two rows of cattle, heads in, and two narrow passageways behind the cattle. This is a misuse of space, more expensive and not a bit more convenient. Far better have one wide space, not less than ten feet, which is less than the three, in the center in which the cattle have ample room to walk quietly to their stalls, where they stand heads to the wall. A hand-cart is used to distribute the feed (before the cattle come in at night) and every animal has the same stall always. Time and time again we have seen seventy head of cows walk into such a stable from three entrances and be tied up and munching their feed in twenty minutes, by two men, with neither noise, hurry, nor confusion.

Every barn should of course have now sufficient at least to supply its inmates with the winter's hay, bins for bran and prepared feed, but corn-cribs should be separate and distinct structures.

In latitudes where the mercury only now and then falls below zero animals suffer more from the barn being too warm and close than from cold. In fact but for the difficulty of properly apportioning feed, so far as health is concerned a good, deep shed, say twenty feet from front to rear, with a hay-rack and plenty of bedding is better than any barn; the air is pure, no drafts and no over-heating and no chilling. Health and vitality are in direct proportion to pure air, and *well bedded is half fed*.

No matter how perfect the barn may be nothing can take the place of abundant bedding, and convenience in getting it in and getting it out (in the shape of manure) easily and rapidly is a thing indispensable. The manure should go direct from the stalls to the pastures and cornfields. For meadows and wheat it must be kept, of course, but not in or near the barn. As long as wheat will pay the cost of production the straw is a sufficient profit to justify the stock-grower in raising it. Sawdust and even dry leaves are useful if straw is lacking. Water in the barn is seldom a suc-

cess. A large central tank of say 200 barrels supplying drinking troughs in every lot, fitted with covers to be closed at night in the winter, seems to serve every purpose, and it is a rare day when all kinds of stock should not be turned out for a few hours at least. Warming water was for a time a favorite "fad" and the writer tried it for one winter; since then the heater has rested in "innocuous desuetude." Thirsty cattle coming suddenly out of an overheated barn may be hurt by drinking ice water, but the cold air has the same effect and the condition of the cattle is the fault.

"Our armies swore terribly in Flanders but it was nothing" to that which ensues when at night or morning "the barn door is off the track." Hinges of course are obsolete. Nothing but the best of rollers should be used, the track of iron, put up as true and solid as it is possible to have it, and then watch and keep clean the groove in which it runs at the bottom. Box-stalls should be built wherever a roof can be extended along the sides without cutting off the light and air from the main building. A long shed closed in front and divided into box-stalls, on the north side of a lot, is of greatest utility. One or two extra warm ones should always be provided a little to one side for winter-night calving, sick animals, etc.

Many patent fastenings have been suggested and advertised, but after all nothing in practice has been found more convenient, more speedy or more safe than the old fashioned German chain cattle tie with about a foot play on a vertical half-inch iron rod under the edge of the manger. The cattle have perfect freedom up and down and can reach to the center of the manger of an eight or nine foot double stall. When taken off the cattle the end ring should be hooked over a nail in the side of the stall just above the animal's neck, where it is just in place for use at night.

By way of supplementing what Col. Harris has said in the foregoing upon cattle barns in general it may be interesting to refer to the diagram herewith given, showing the plan and method of construction adopted by him in a cheap cattle barn which he built upon his farm a few years ago. As will be seen it fully carries out his idea that an expensive, elab-

orate barn is a necessary adjunct to successful cattle breeding in the Western States, but that reasonable shelter for the herd from the rigors of winter and some little outlay for

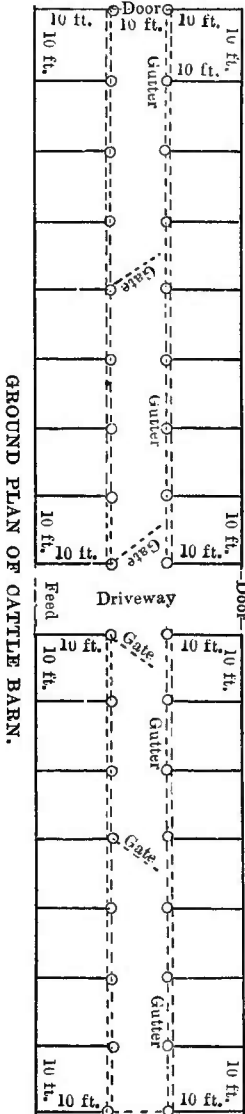

GROUND PLAN OF CATTLE BARN.

the protection of the hay is in keeping with the best principles of economy. The unpretentious yet admirably arranged building (briefly described herewith) was built at Linwood a few years ago, and has given the best of satisfaction. The material used in its construction was as follows: 32 telegraph poles, 20 ft. long; 32 telegraph poles, 25 ft. long; 6,000 ft. of boards, 16 ft. long; 30,000 shingles; 400 battens, $3 \times \frac{1}{2}$, 16 ft. long; 34 sash, 4 lights, 10×12 ; 4,500 ft. of flooring; 200 joists, 2×8 , 16 ft. long; 2,500 ft. of rough boards; 250 pieces, 2×4 , 16 ft. long; 1,400 ft. of masonry in underpinning.

Concerning the advantages of the plan of arrangement followed out Col. Harris writes:

“In reply to your favor regarding the barn which has attracted your favorable attention I would say that the points in its favor are cheapness, light, ventilation, and ample room. The wide alleyway permits the ready and uncrowded passage of cattle, and the same is true of the stalls. Wagons go through and take up the manure, which goes direct to the fields. Bedding is distributed in the same way, and we are now using hay from the outside distributed in this way, holding in reserve that in the mow. Our pastures are arranged so that cattle come in from three

different lots without interference or confusion. The dirt floor is cheap and never slippery and we are not annoyed by rats. The holes which wear are readily filled by a load or two of dry earth which is at once an absorbent and deodor-

izer. We have all the windows open on one side or the other (to the leeward) and have no wheezing or coughing. It was built by two carpenters and four laborers in thirty days, cost about \$1,100, and can be afforded by any farm of 160 acres. The mow holds near 140 tons of hay by filling up after the first has settled. It now has tied up fifty-six head of cows and heifers, and their calves loose. The roof of the north side will be extended sixteen feet next season so as to make fifteen box-stalls 10x16, the windows of which will be opposite those in the barn so as to permit the free passage of air. It will cost only about \$350 or \$400 to do this and will then

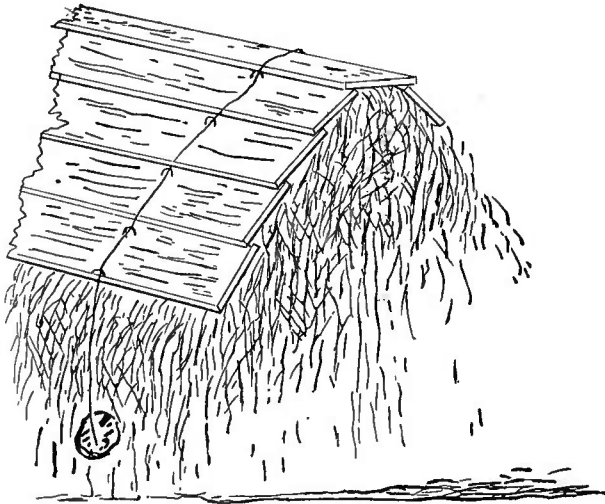

shelter more cattle at less cost and in a healthy way than anything I have seen."

A simple and inexpensive device is employed by Mr. Harris for the preservation of hay put up in "ricks" or stacks, a rather crude illustration of which is herewith appended. As to its construction, which is of the simplest character, Col. Harris says: "In making this cheap hay cover we use common boards twelve to sixteen feet long, a foot or more wide, putting one on top of rick first, then slipping one on each side under the top one about two inches and fastening by driving a common fence staple over a number nine smooth wire just at the edge of the upper board so as to make a sharp bend in the wire over the edge of the

upper board, and so on down as far as wanted; six to eight boards on each side are generally enough; then fasten a good-sized stone in the end of the wire and the thing is done—two wires to each length of board about two feet from ends and as many sections as may be needed for the length of rick, putting the middle section on last with ends lapping over the next ones. In using the hay a single section is taken off by drawing out the staples and the rick cut down so as to leave the cover on the remainder. Boards and wire can be used over and over.”

PLAN OF BARN SUGGESTED BY HON. T. C. JONES,
DELAWARE, O.

The building may be 40 ft. in width, to allow two rows of stalls, each stall being 8 ft. long, with a gutter of 1 ft. in the rear; and a space of 6 ft. between the gutters and the outside walls would leave, after allowing for space taken up by walls and partitions, 8 ft. for a passageway.

To afford ample room above for the storage of hay, etc., the posts may be 25 ft. long, which, assuming the stable to be 9 ft. high, would give about 14 ft. in the clear for the upper story.

The length of the building will depend upon the number of cattle we wish to provide for. Allowing 8 ft. in width as ample room for double stalls for large cattle, a barn 90 ft. long would accommodate, say, forty-five or fifty head of different ages, the younger animals requiring much less space, besides giving room for boxes for calving cows and cribs for calves, meal boxes, etc. The apartments for the calves should be cribs made of strips of boards 3 in. wide, with spaces of about the same width between, because the air near the floor is always foul where young calves are kept in close boxes, even when they are open above. These cribs may be movable, and constructed with only one side and two ends, the stable wall, to which they may be attached by a movable fastening, forming the other side. The space of 7 ft. behind the cows would allow the placing of these cribs there, as would be convenient for very young calves.

The chaff-cutter may be in the upper story; and at intervals of 20 to 25 ft. in the middle passageway there should be conductors extending up through the hay loft to the roof and

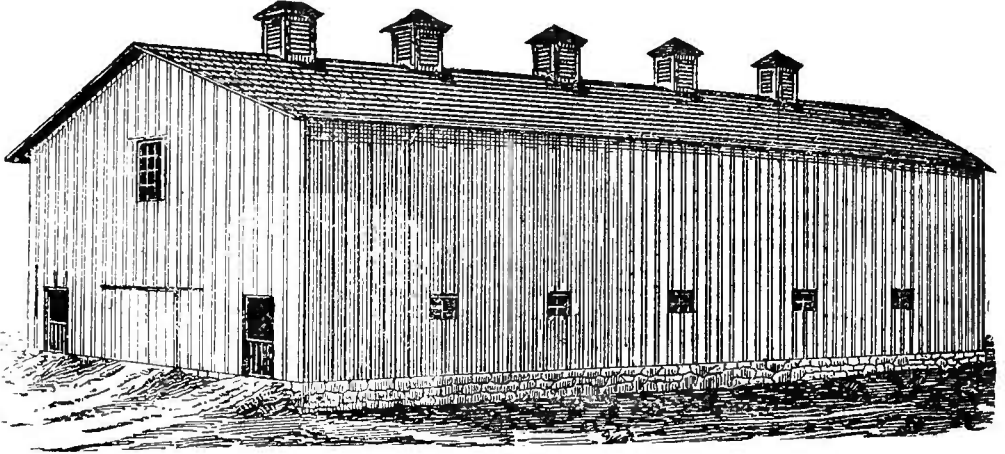

ELEVATION.

terminating in well-constructed ventilators. These conductors or chutes should be about 4 ft. square, with openings in the upper story to let down into the passageway hay, chaff, etc.

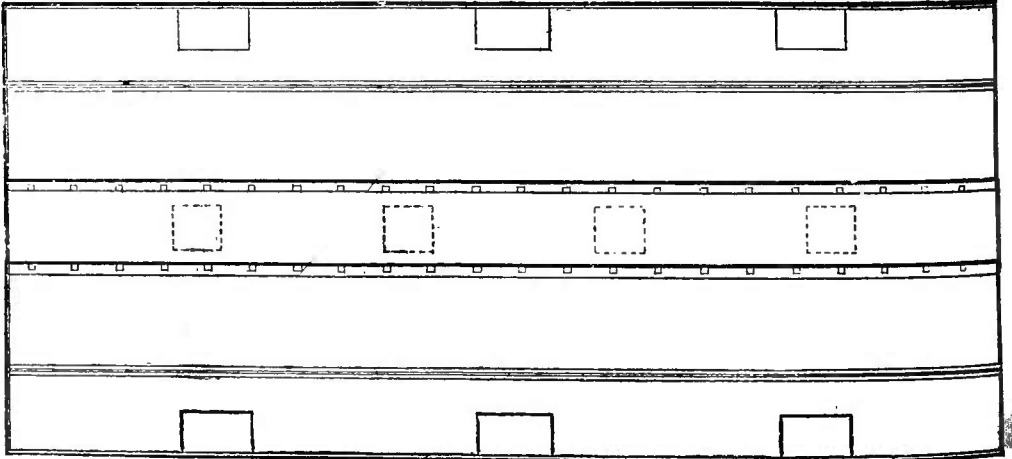

GROUND PLAN.

The mangers will be about 22 in. wide, and 2 ft. high above the floor of the stalls, and the bottoms should be about 6 in. above. The floors for cows may be of dry earth, with a square timber for the inner side of the gutter, which may be

made of hard-wood plank, and the space between the gutters and the walls may be paved with cobblestone. Sometimes planks are used for this purpose; but as cattle are liable to slip and fall in passing in and out on these floors the stone pavement is preferable. A box for meal, bran, etc., 10 to 12 in. wide and about 10 in. deep, may be placed in the manger at each corner. The top of the outside of the manger should be a 2x4 in. scantling, in which, near the meal box, holes will be bored for the chain ties with which the cattle are fastened. The advantages of the double stalls are that less space is required for a given number of cattle than where each has a stall to itself. A large cow would not be comfortable in a stall 4 ft. in width, while 8 ft. will give ample room for two—it is also found that there is great convenience in having the long manger for feeding shock-corn, etc., as may be done in the double stalls. The barn should have suitable openings for light and air, some of which should have glass widow sash, and all be provided with proper shutters. All the doors should be made with upper and lower halves, not only because they are more convenient and lighter, but for the reason that the upper halves may be left open for ventilation when necessary.

MR. H. H. CLOUGH'S BARN, ELYRIA, O.

The accompanying plan is that of a cattle barn in use by Mr. H. H. Clough near Elyria, O., specifications for which are as follows :

Walls to be of stone up to joists of main floor—two feet thick at ends, eighteen inches at sides—and of suitable thickness and depth below ground, according to nature of soil. Frame to be of 8x8 stuff (plate beams 7x7), put together with mortise and tenon and stayed with braces and girders between sill and plate-beams, the interior frame extending to and supporting roof. Besides the four corner posts of frame there are to be five posts on each side, two on each end and two sets of five each in the interior, placed as shown in cut. Rafters to be of 2x6 stuff, two feet apart, projecting two feet at eaves and gables. Joists to be 2x12 and one foot

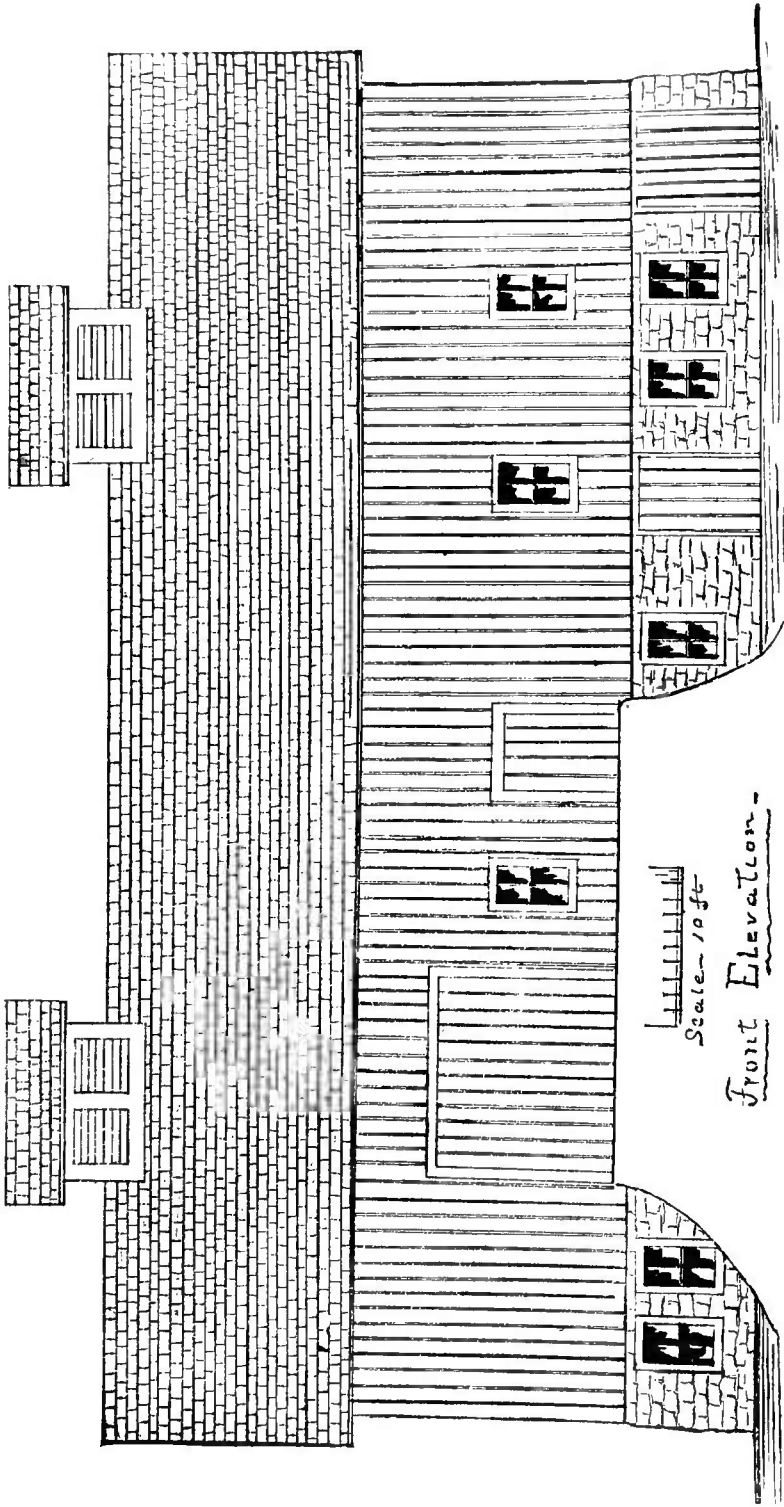

Scale 10 ft

Front Elevation

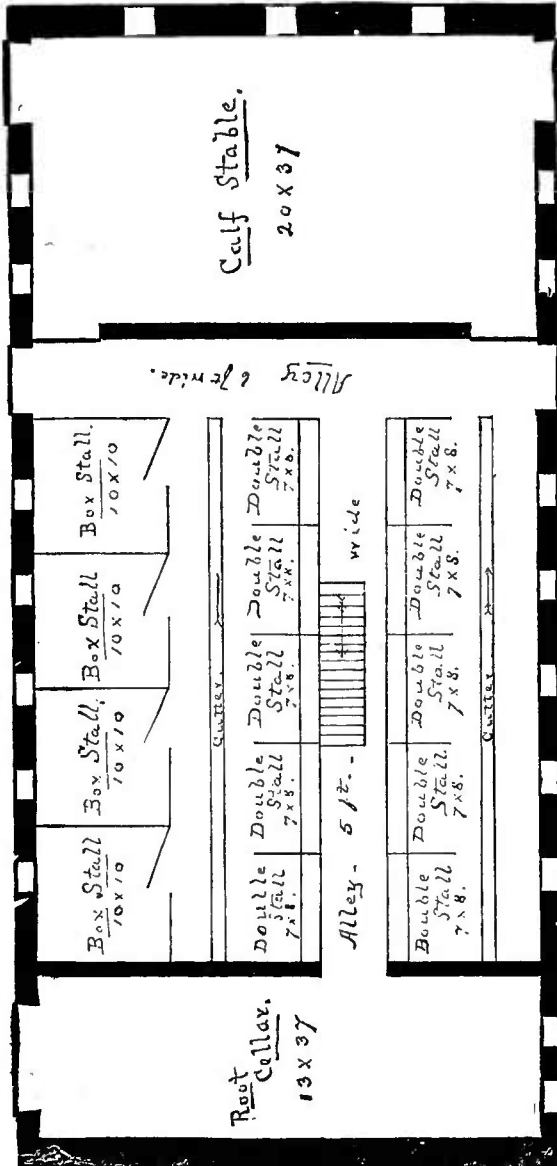

Basement Plan
Scale - 1/8" = 1'

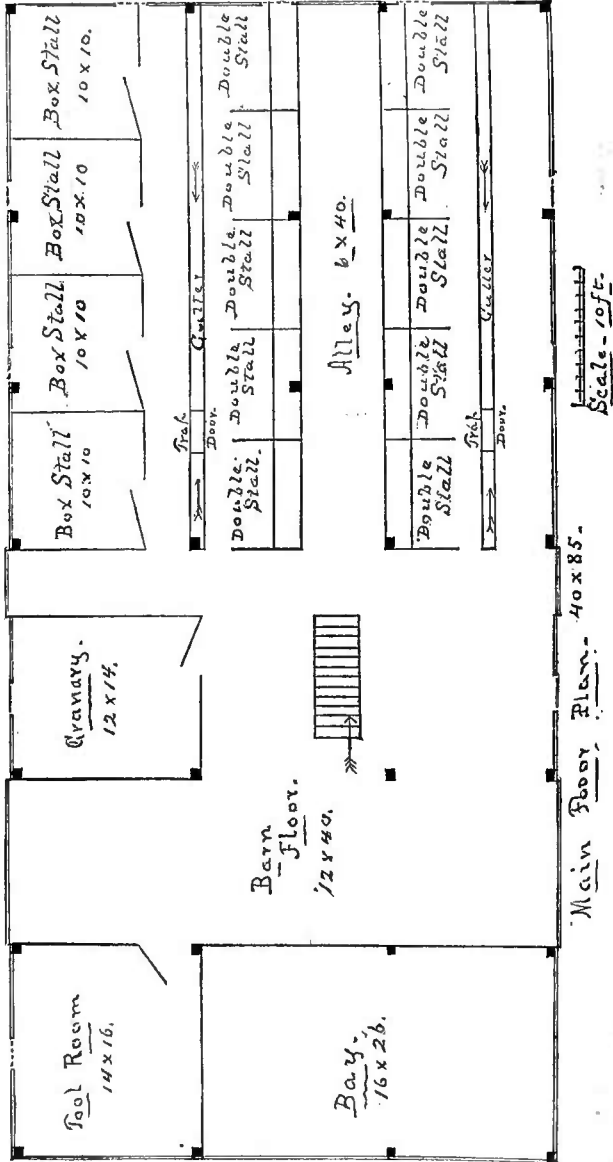

apart. Sides to be of 12-in. barn boards planed on one side and cracks battened. Flooring and sides of stalls to be of 1-in. hard-wood lumber. Floor of loft, and sides, and ceilings of tool-room and granary to be of matched lumber. Barn floor to be of two thicknesses of 1-in. oak, lapped and matched. Windows to be 2 ft. 6 in. x 4 ft. 6 in. Basement elevation 8 ft. 2 in. to joists. Floors of stalls to be slightly raised at head for proper drainage, and gutters ditto, as indicated by arrows.

Although built with a stone basement this is not a "bank barn."

We are advised that the cost of this building, unpainted, was about \$2,000. It is a large and commodious structure designed for the special accommodation of a herd of pure-bred cattle, and has given Mr. Clough the best of satisfaction.

MR. E. W. PAYNE'S BARN, MORRISON, ILL.

In sending us the sketch from which the engravings on the following page were made Mr. Payne writes :

It is strictly a cattle barn ; is set upon concrete piers, made of cement and gravel, each pier standing upon a footing 2x3 ft. and 6 in. deep, made of best Portland cement to resist frost. These piers are 2 ft. long, 14 in. thick at bottom and 10 in. at top, and 18 in. high, standing 10 ft. to centres, and are made of Louisville and Akron cement and gravel. I think they cost more than stonework would have done, but the expense might have been lessened by using some quicklime. The sills are 8x8, and lower joists 2x8. The main barn is 32x80, and built after a design of my own. The bents of the frame are 10 ft. to centres, and each bent is constructed of two 2x6 studding for each outside post, and the inner posts which slope slightly outward at the top, with a tie joist reaching through from outside to outside, spiked between the two studding. These bents are fastened together by ribbons 2x6, gained in a half inch, and gained into the studding $1\frac{1}{2}$ in., bringing the ribbons flush. The second joists are supported by a 4x4 cut between the inner

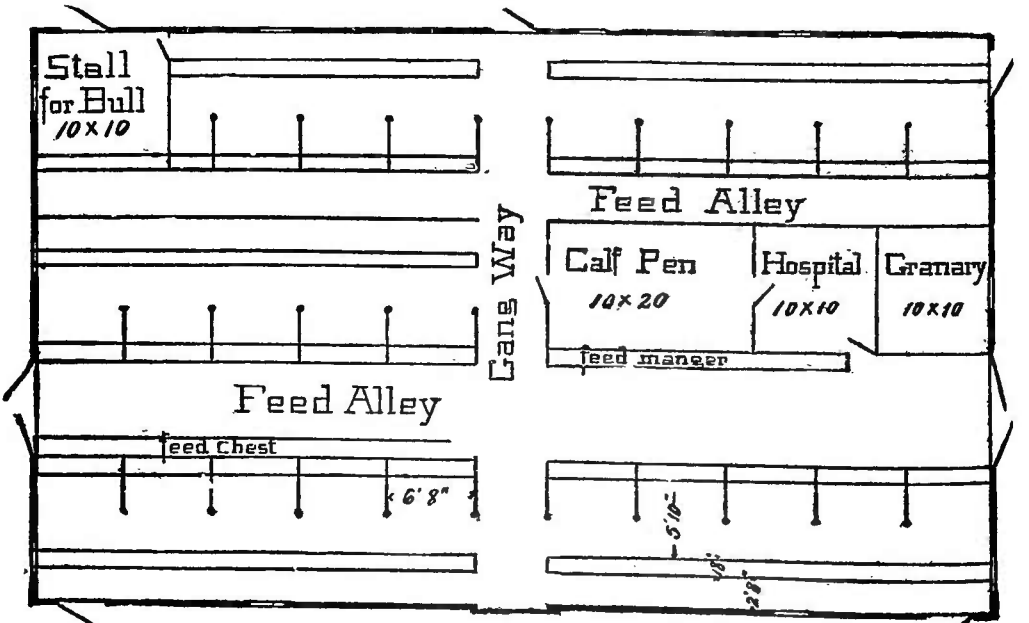
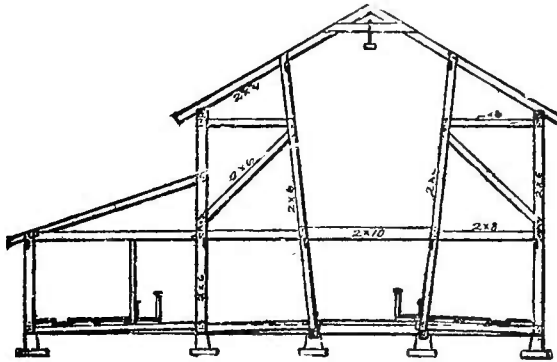
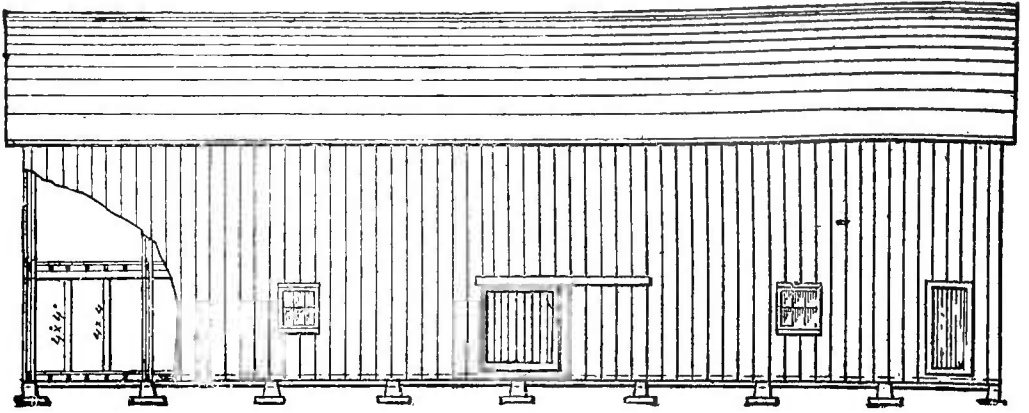

ELEVATION, SECTION, AND GROUND PLAN.

posts and beveled on top to take the bearing of the joists, and are supported by three 2x6 studding for each 10 ft. set upon the sill and cut under the ribbon and 4x4, these short studding being set at the same slope as the posts, and 3 ft. 4 in. to centres, which is the space allotted to each animal. The hay loft is clear from the floor to the peak, in which a track is constructed and a hay-carrier used. The hay is mowed between the bents at the sides with very little labor. The track does not extend outside of the barn, and no difficulty is found in operating the carrier six feet to one side of the load. The floor is divided into double stalls 6 ft. 8 in. to centre, and the partitions extend across the manger. Cattle are tied with chains attached to an iron staple at the side, upon which the chain can slide up or down sixteen inches. A feed alley runs through the whole length of the main barn, cattle standing with heads to the centre. There is on one whole side an addition 16 feet wide arranged in stalls and a box-stall for a bull, which opens into a yard for exercise, as shown in the diagram.

A discrepancy will be observed between this description and the plans in regard to the supports for the second joists. This *description* is according to the facts, and is better than the perpendicular support as shown in the plan.

MILLER & SIBLEY'S BARN, FRANKLIN, PA.

Perhaps one of the most complete, elaborate and convenient barns for dairy cattle in this country is that of Messrs. Miller & Sibley of Franklin, Pa., well known on account of their success as breeders of Jersey cattle and trotting horses. The description, which is quite full, will form a profitable study for such of our readers as desire to adopt the octagonal form in barn building. Messrs. Miller & Sibley describe it as follows:

Our barn, as will be seen by reference to the cuts accompanying, is a polygon of sixteen sides. There has been no attempt made at display. We hope, however, that nothing has been neglected which can add to the comfort or health-

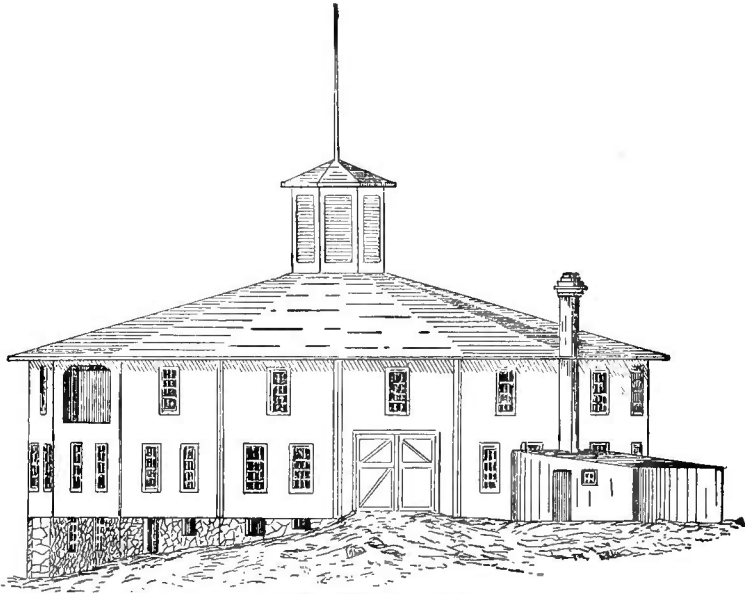

ELEVATION.

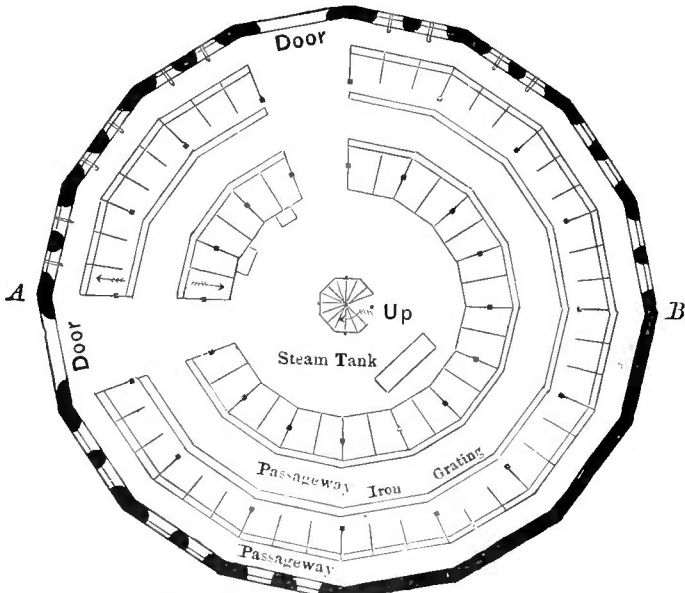

PLAN OF BASEMENT.

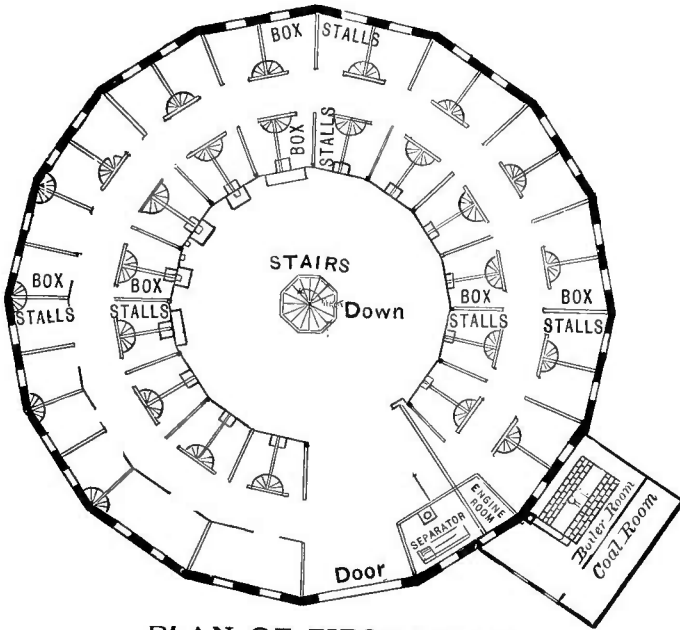

PLAN OF FIRST FLOOR.

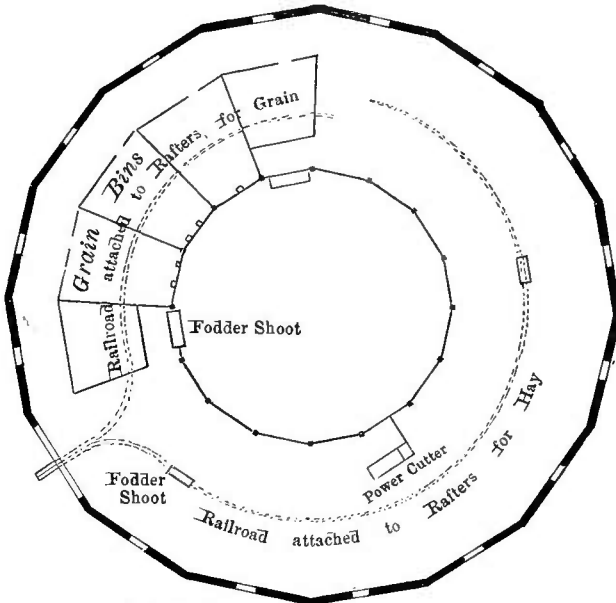

PLAN OF SECOND FLOOR.

fulness of the herd, for we maintain that perfect health is the first requisite for the breeding of butter-producing animals.

The barn is heated by steam, and in winter a uniform temperature of from 40 to 45 deg. Fahr. is maintained night and day, never colder than 40 deg., never warmer than 45 deg. Self-registering thermometers, in locked cases, show, at all times, any variation from this temperature. We do not think any one can charge us with keeping our cattle in a

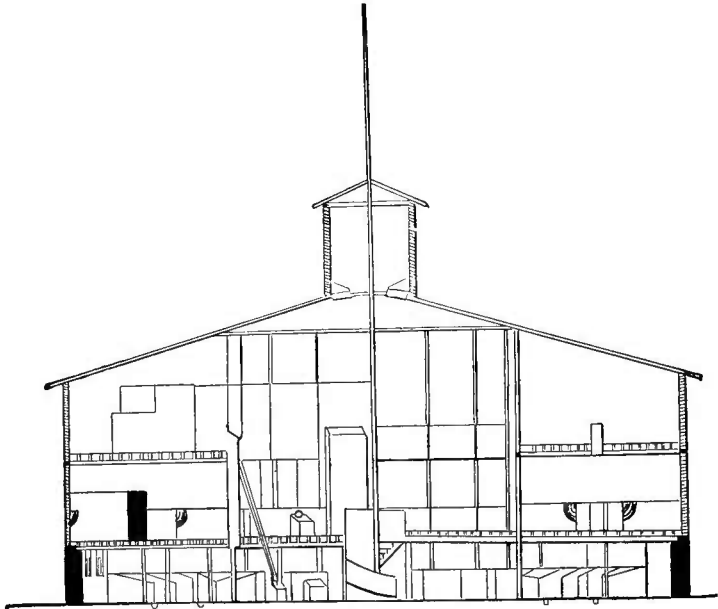

SECTION A. B.

hot barn, the aim being only to maintain a temperature just above the freezing point.

More attention to proper ventilation has been paid than to all else, and we doubt if any private house or public hall is more perfect in this respect. The barn is surmounted by a cupola twenty feet in diameter. This is open every day and night in the year. The lower sash of each window is raised eight inches and a board placed under the sash. A hole six inches in diameter is cut through this board, in which is placed a zinc pipe, opening outwardly, and turned up on the inside some three feet in height. This allows for the admis-

sion of air between the two window sashes, and also of a full current of air through the six-inch pipe, thus preventing any possibility of a current of air striking directly upon the animals. By this arrangement, no matter what the weather may be, a full supply of pure fresh air is given to every animal by the current from the lower floor passing up the stairway in the center of the barn, and also through two chutes extending from the lower floor well up toward the roof.

The basement of the stable is devoted mainly to the milking cows. It is laid with concrete. Gutters, covered with iron gratings, extend back of the cows and terminate in a sewer which leads 100 rods away from the stable. This floor can be scalded out with hot water, the gutters and sewers flushed, and the cattle put back in the barn on a dry floor in an hour's time.

The first floor is of two thicknesses of matched yellow pine, with tarred paper between the layers. Sawdust is used for bedding on this floor, which is devoted mainly to box-stalls, both open and tight, for the service bulls and for cows soon to calve.

In a room on this floor is placed our cream separator and engine. On this floor is also our cleaning machine, which, by a system of revolving brushes, cleans a cow perfectly in from three to five minutes' time. During the winter months each cow receives a daily cleaning, three men being able, by this method, to thoroughly clean 160 head per day.

The second-floor space is devoted to storage for fodder, grain, and bedding, and also for our power cutter, which cuts one ton of dry corn-fodder into one-third inch lengths in twenty-five minutes.

The barn is lighted by sixty incandescent electric lamps. A night watchman is employed who, at intervals of every half-hour, makes a complete tour of the stable, seeing that all is well, a touch of the button enabling him at any time to notify the Superintendent of anything wrong. To insure the watchman's wakefulness and attention to duty an electric time detector is in use, which keeps perfect record of his movements through the barn.

MR. C. S. BARCLAY'S BARN, WEST LIBERTY, IA.

Mr. C. S. Barclay, a well-known Short-horn breeder of West Liberty, Ia., has recently built a barn which may commend itself to other breeders as affording shelter for a large number of cattle, as well as a goodly store of hay, at moderate cost. Particulars as to construction are furnished by Mr. Barclay, as follows:

For frame of barn, 18 pieces 6x8 in.x24 ft.; for end center posts, 2 pieces 6x8 in.x22 ft.; posts for doors and girths, 12 pieces 4x4 in.x12 ft.; posts for doors, girths, etc., 12 pieces 4x4 in.x16 ft. and 1 piece 4x4 in.x14 ft.; rafters for main building and outside shed, 50 pieces 2x6 in.x16 ft.; rafters for first shed, 22 pieces 2x6 in.x20 ft.; for plates for outside shed and girths on which to nail the siding, 38 pieces 2x4 in.x16 ft.; for plates and girths for first shed, 51 pieces 2x4 in.x16 ft.; braces, 246 pieces 2x6 in.x12 ft.; hip rafters, 2 pieces 2x6 in.x26 ft.; girths for ends of barn, 16 pieces 4x6 in.x12 ft.; girths for ends of barn, 2 pieces 4x6 in.x16 ft.; plates for main barn, 30 pieces 2x8 in.x12 ft.; roofing boards 12 in. wide, with hollow batting 4 in. wide and 1 in. thick laid under the boards, all well painted with mineral paint; upper roof 16 ft. boards, 15 in. projection, with eave trough to carry water off made of 6-in. fencing; second roof covered with 20 ft. lumber, projection and eave trough same; siding boards 12 in. wide, battened with O. G. bats; doors hung on rollers; windows for each box-stall, 4 lights 10x12 in.: 4 in shed end, 4 lights 10x12 in.: 2 in front end, 6 lights 10x12 in.; box-stalls all boarded on the inside four to five feet high and have double partitions where not made of 2-in. plank; bull-stalls made with doors opening into stable and outside; feed trough 8 in. deep, 12 in. wide at bottom and 16 in. wide at top; hay-rack made of 4-in. strips 4 ft. high, bottom tight, and made so that all chaff and seed falls into feed box; double stalls for cows 7½ and 8 ft. wide, with floor for cows to stand on 6 ft. long. Of the posts used for sheds the longest were 22 to 24 ft., set in the ground 2 ft.; the outside ones are from 10 to 14 ft. They are swamp burr oak, cut in May and peeled; used

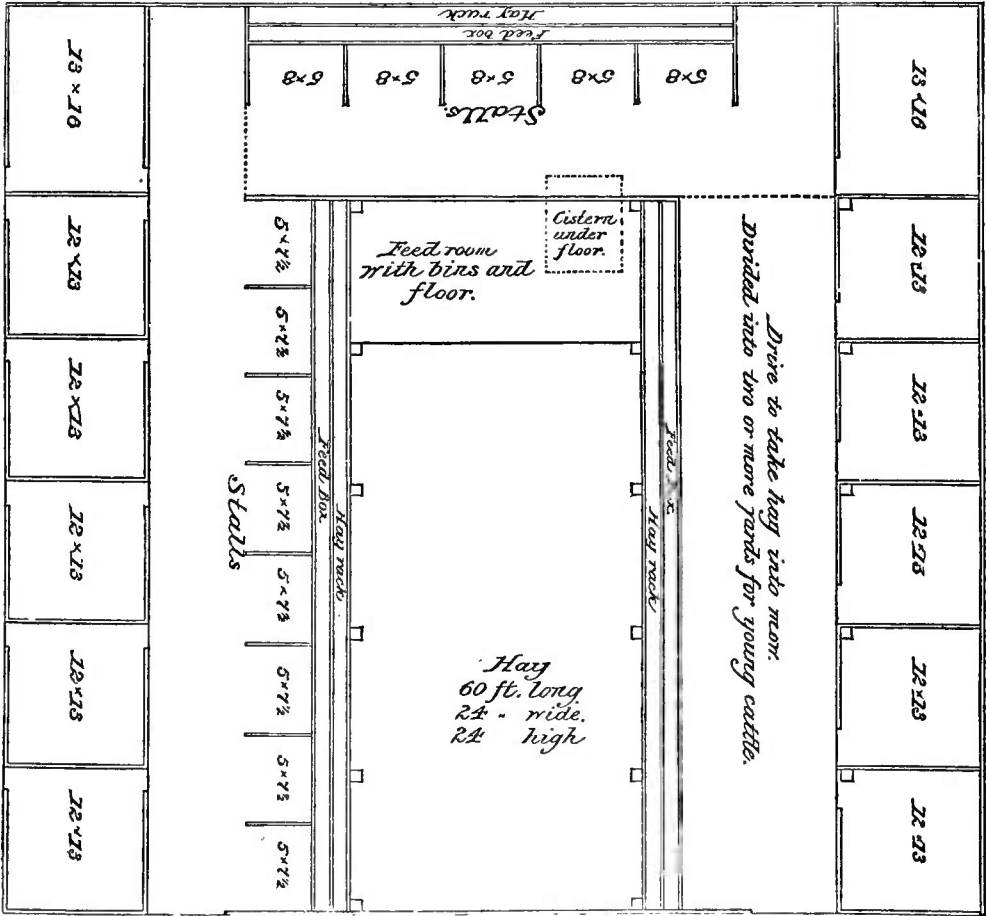
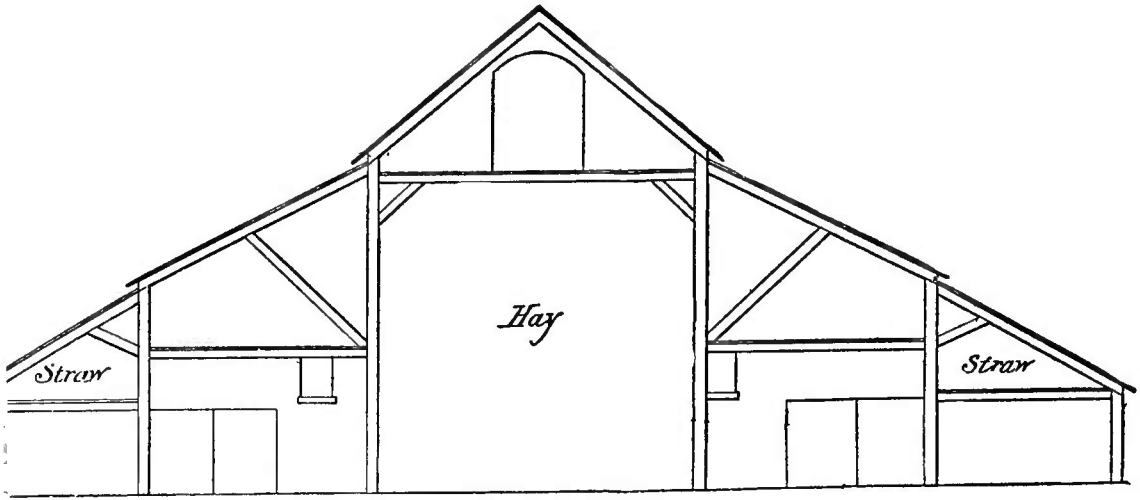

CROSS SECTION AND GROUND PLAN.

38 of these. Building is well braced throughout and strong enough to stand anything but a tornado. Posts of frame are set on heavy burr oak blocks, with brad in bottom of posts. We calculate we have room for 150 tons of hay and straw for bedding for the winter.

This barn will accommodate over eighty head of cattle and its total cost was about \$700.

MR. ORLANDO CRITTENDEN'S BARN.

Mr. Orlando Crittenden, an Ohio cattle-breeder, describes the barn herewith illustrated as follows:

I built this barn expressly for the winter quarters of my herd of Short-horns. It is a bank barn on nearly level ground, there being but a slight rise. The barn is 44x80 ft., posts 24 ft. running from wall to plate, setting 16 ft. apart. Lower story 8 ft. between shoulders, and wall 18 in. high, making in all 9 ft. 6 in. We use dirt floors, so you can see at once that the stable is warm; the windows have blinds, but no glass, so that the temperature can be easily regulated by opening or shutting the slats. The upper flooring is matched the same as house flooring, so no seed or dirt can get through on the cattle. We have plenty of ventilation above, as I will show later. I drive in on the upper floor from the back side of the barn, not shown in the sketch. I have a bridge running back 16 ft. with some slope, and from that back it is graded so that a team can easily walk in with a ton of hay. I stow all my grain above and thresh above, keeping all the straw in the barn for use as bedding.

Plan of basement—44x30 ft.; *a a*, cow stable, with double stalls; *b*, calf stable, the same; *c*, bull stall, 8x16, which is ceiled tight; *d*, room 10x16, which is plastered and has a chimney for stove (this room is for the herdsman, as he is needed by night as well as by day); *e*, granary, 8x16 (this is filled from above); *f*, alley or feeding floor 12x68 (this floor is two feet above the ground or stable floor; the hay is fed by pushing off each side, which falls into the mangers); *g*, stairway; *h*, entrance; *i i i*, water tanks (water is pumped in the

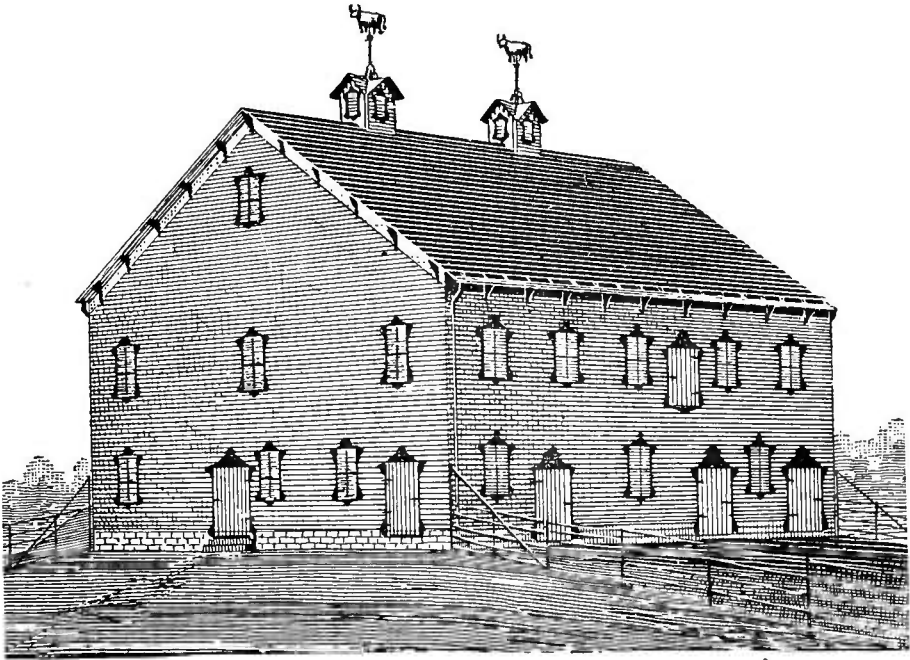

ELEVATION.

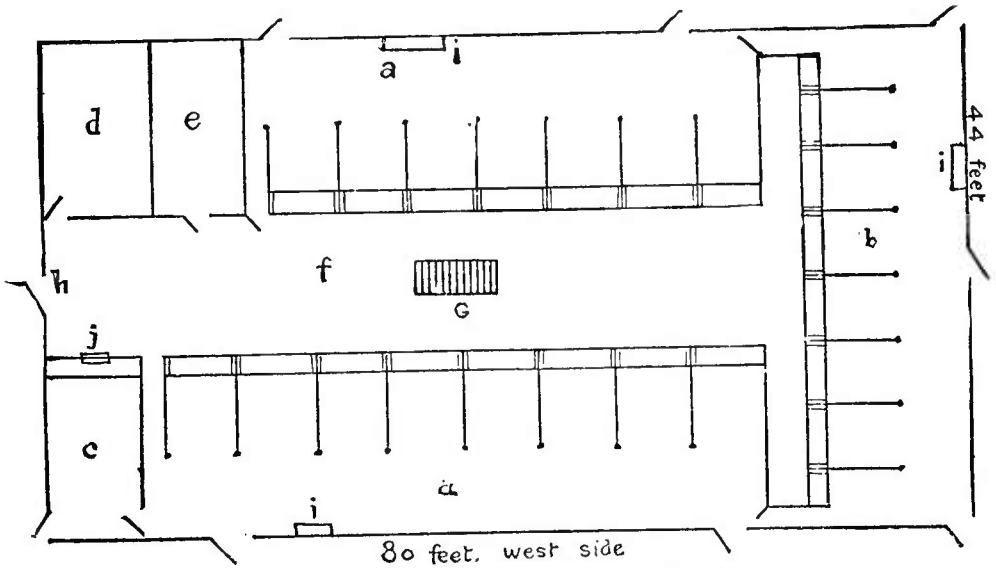

80 feet, west side
DIAGRAM OF MAIN FLOOR.

barn by a windmill which stands about ten rods from the barn); *j*, door, sliding up on rollers between the ceiling and the place where hay is put in for the bull.

Plan of upper story—1, straw mow; 2, driveway; 3, hay mow; 4, alley 4x32 (this is for carrying grain to granary

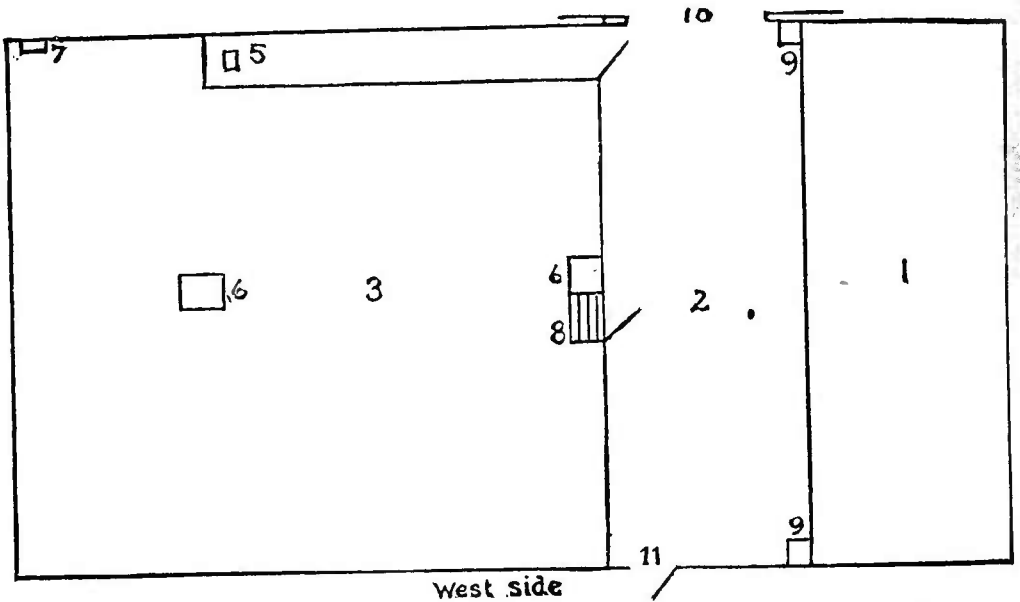
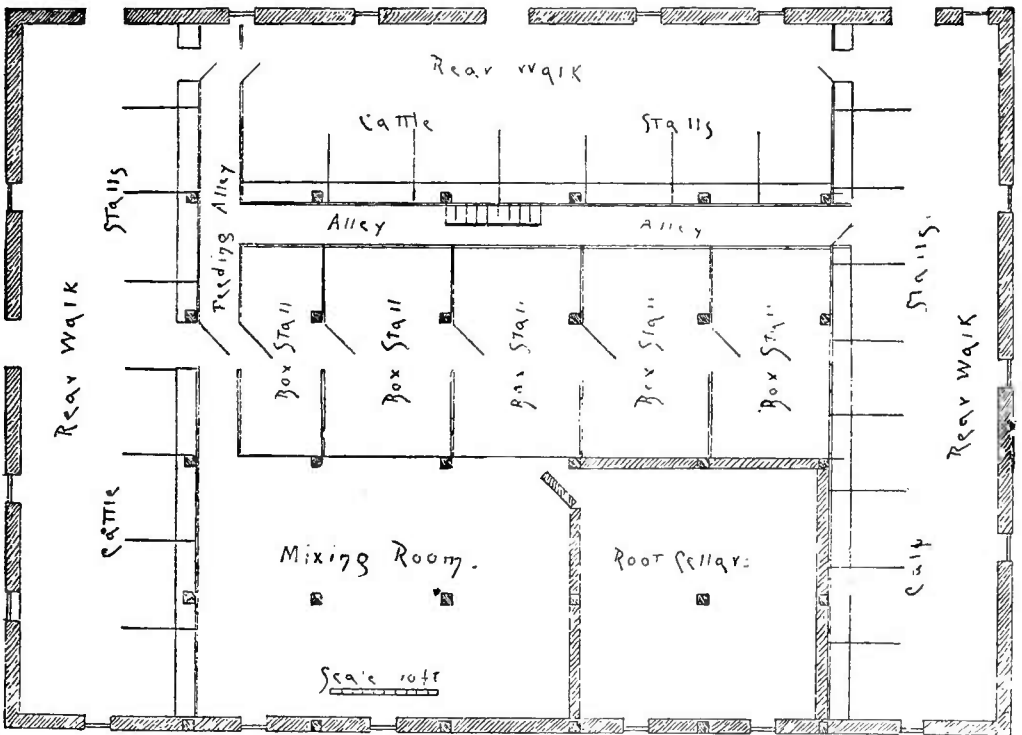
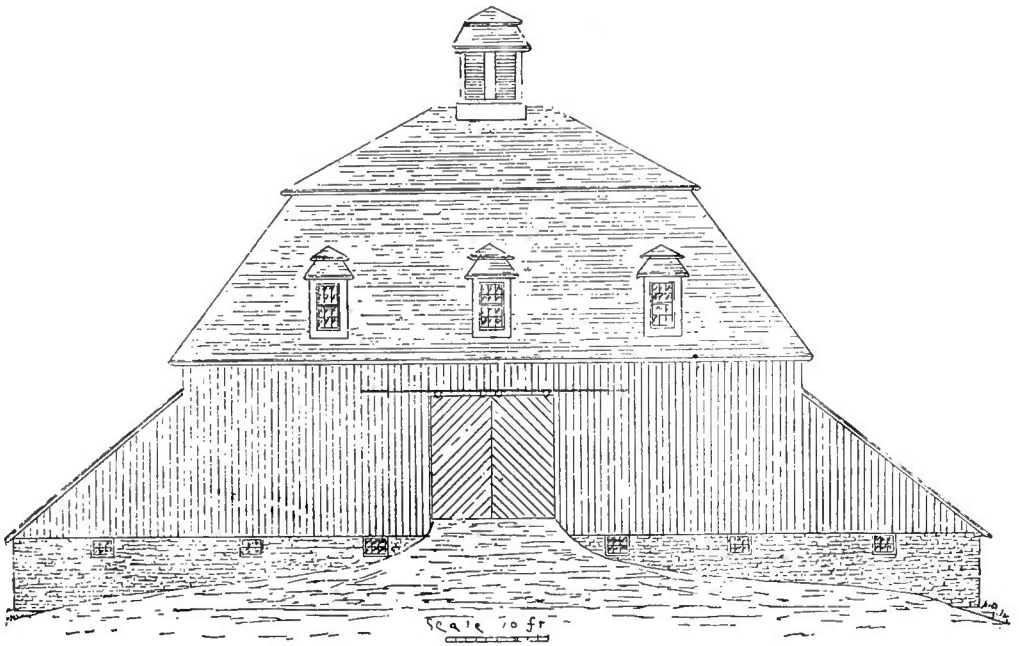

DIAGRAM OF SECOND FLOOR—CRITTENDEN BARN.

when thrashing); 5, hole in floor over granary; 6 6, hay chutes 4x4, with doors to open as the hay lowers in feeding; 7, chimney; 8, stairway; 9 9, straw chutes, the same as the others; 10, double doors for driving in; 11, the door for the belt of the machine when thrashing. The four chutes give ventilation from below.

MR. THOMAS CLARK'S BARN, BEECHER, ILL.

Mr. Thomas Clark of Beecher, Ill., the well-known Hereford breeder. has a remarkably compact, convenient, and substantially-built cattle barn, the most noticeable feature of which is its immense capacity—both in the way of loft room and accommodations for cattle—all in such a very compact shape; and it is on this account, and in the same ratio, con-



ELEVATION AND GROUND PLAN.

venient. It will not require a mule cart and a half-dozen men to feed the sixty to seventy head of cattle this barn will accommodate. On the contrary, we venture to say that Mr. Clark with his own hands will be able to deal out the rations of roots and hay in one short hour of a cold winter morning.

The main part of the building is 50x60 ft., the outside posts of which are 18 ft. from basement ceiling; and inside posts 34 ft. extending to and supporting the hip roof. Upon three sides of this structure there is a 17-ft. lean-to, making a total ground floor (it is not properly a basement) of

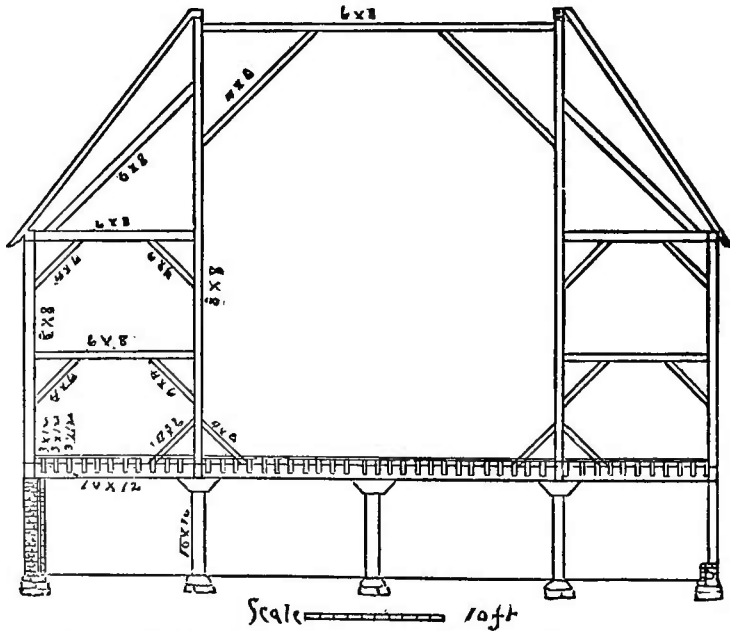

SECTION SHOWING CONSTRUCTION.

67x94 ft. This is to be used as shown in diagram. The foundation upon the front side abuts a bank, giving easy access to the barn floor above. The wall is 19 in. thick, of brick, and is built up about 7 ft., the height of ground floor; upon the other three sides it is only a little above ground. Piers under each post support the main part. The posts of lean-to are 4x6 in., 7 ft. high; sills 6x8 in.; rafters 2x6x24 ft., 3 ft. apart; siding 8-in. shiplap laid up and down; posts supporting main part are 10x10 in., about 7 ft. high with caps; 12x12 sills upon each set of these support the joists, which

are in turn very heavy—3x12—11 in. apart, and are set into the sills 3 in. and 8 in. deep, thus having 4 in. of the width of the joist extending over the sill. This arrangement saves space and makes things very secure. The first section of roof is a two-thirds pitch, and upper part one-quarter pitch. Eaves project 16 in. and are boxed in all round. Cupola is 6x6x6 with 8-in. eaves. Dormer windows to loft 6 ft. high with twelve 8x10 lights. There are two such windows also on each side and three in rear. There is an air-space chamber in the front foundation wall to prevent frost entering.

The ground floor is of crushed stone and cement, with proper fall to rear of cattle. The loft floor is of matched lumber; roof of shingles, of which, by the way, it takes about ninety thousand; but much of this expense is saved in the siding. The total cost was about \$3,000, the several items of which are not at hand.

MR. WILL R. KING'S BARN, MARSHALL, MO.

The engraving on next page illustrates the barns of Will R. King, at Peabody, five miles south of Marshall, Saline Co., Mo. It is arranged so as to provide comfortable quarters for 100 head of cattle. The windmill as shown in the engraving is a five-horse power double-header and furnishes power to run the corn-sheller, feed-mill, and hay-cutter. The loft in the barn, shown on the right as you face the page, has in it a hay-cutter and will hold 100 tons of hay. The loft over the horse barn, shown on the left, will hold fifty tons of hay, and the corn-crib holds 2,500 bushels of corn in the ear. The ground adjoining this barn is divided off into suitable dry lots which are provided with racks for feeding hay to stock when not in the barn. The posts are sixteen feet. At the lower left-hand corner of the diagram is shown a row of sheds opening into the barn-yard with hay-loft overhead. The horse barn proper is 60x40 ft. and the cattle barn 120x38 ft. The elevation shows the horse barn on the left and the cattle barn on the right, the two connected by the mill-house, 14x35 ft. The diagram is explained as follows:

B S—Box-stalls. *S D*—Sliding door. *C P*—Calf pens.

B—Stall for bull. *CH*—Cut hay. *FB*—Feed-bins. *MH*—Mill-house. *S*—Shelter. *CC*—Corn-crib. *S & H*—Shed and hay-loft. *HF*—Hay-feeder. *H*—Harnesses and saddles. *C*—Carriages. *G*—Granary. *HR*—Harness repair. *BY*—Barn-yards. *F*—Fence. *WM*—Wind-mill. *HB*—Horse barn.

C. W. NORTON & SON'S BARNS, DURANT, IA.

The special features of the plan of the barn of C. W. Norton & Son of Durant, Ia., presented herewith, are its wonderful cheapness and its great capacity both for feed and stock. The main building is devoted entirely to hay or fod-

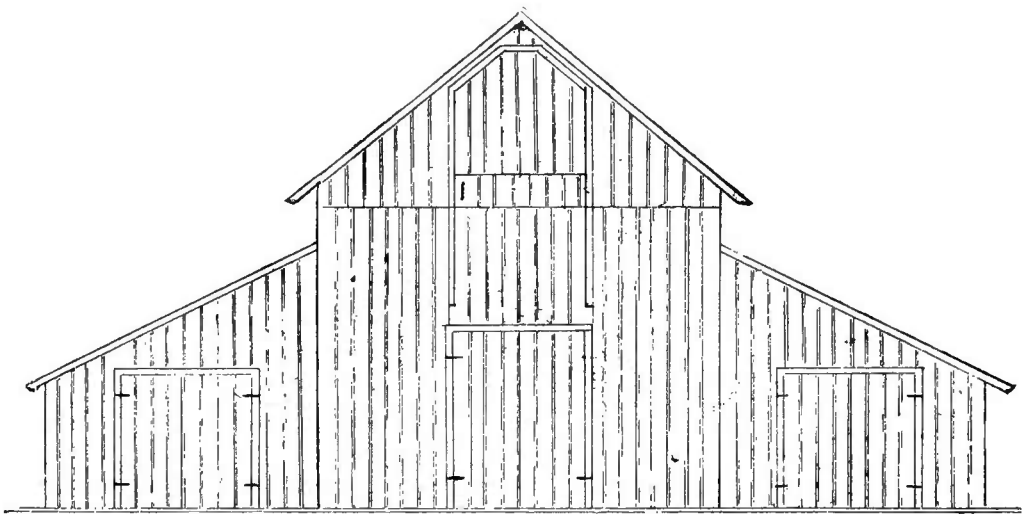

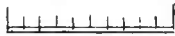
Scale  10 Feet

END ELEVATION.

der room, and the "lean-to" sheds afford protection and feeding space for much more stock than many a more expensive barn and any part of them may be readily partitioned off into stalls of any desired size. The Messrs. Norton have two such barns, one for cattle and the other for sheep, and are much pleased with them.

The frame of the main part of the building consists of posts 20 ft. high and 3 ft. below ground, placed 8 ft. apart as shown in diagram. The posts of the shed are 8 ft. high. The posts

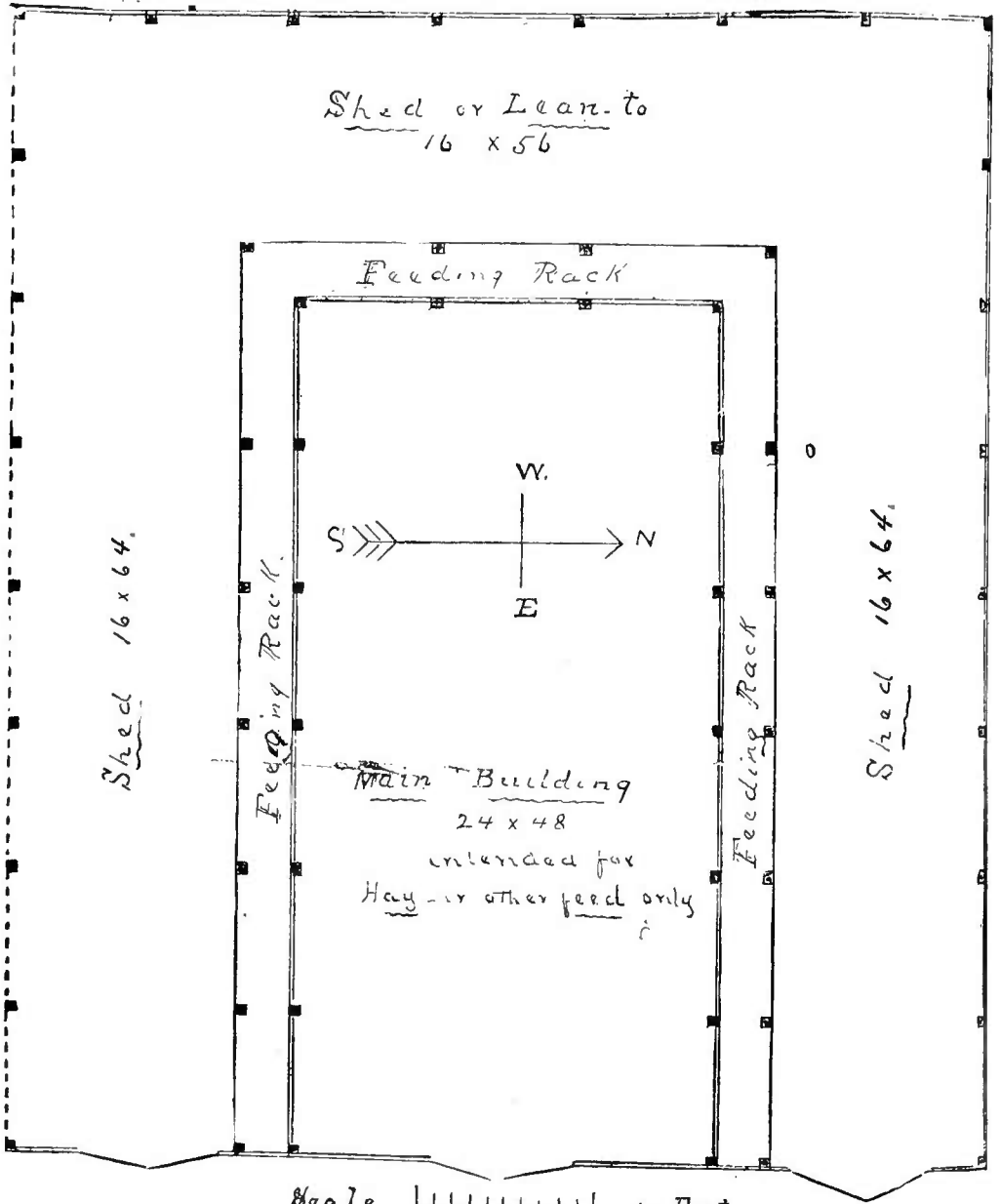

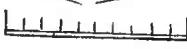
Scale  10 Feet
GROUND PLAN-NORTON BARN.

of the feeding racks extend obliquely to and support the roof of the sheds. The plate beams are of 2x6 scantling and spiked to posts. The roof consists of 2x6 rafters 8 ft. apart, with two sets of 2x6 girders between eaves and ridge-pole and covered with 12 in. barn boards planed on one side. The shed roof is of same material. The frame is stayed and made firm by the support of the "lean-to," and there are also girders of 2x6 stuff across the main part every sixteen feet. The sides are of 12-in. barn boards and battened. The shed upon the south side is not boarded up. The large doors at gable end are desirable in order to drive in and out to haul away manure.

Expense items are as follows: 8,000 ft. boards at \$16, \$128; 8,000 ft. battening at \$4, \$32; 1,500 ft. rafters, girts, etc., at \$14, \$21; Carpenters, hardware, etc., say \$19. Total, \$200. Should it be necessary to buy lumber for the posts, 1,800 ft. are added, at \$14, \$25.20. Grand total, \$225.20.

MR. DAVID E. CUNNINGHAM'S BARN, AMANDA, O.

Mr. David E. Cunningham of Amanda, O., has recently completed a barn diagrams of which are herewith presented. It is built on a roomy, liberal scale, with a 20-ft. floor in centre. It is 22 ft. sill to plate, stabling 8 ft. in the clear with dirt floors. The sills are 12x12, balance of frame principally 8x8. Joists of barn floor 2x10, 15 in. apart. Joists of loft 2x8, 15 in. apart. Joists of alleys 2x6, 15 in. apart. Rafters 2x5, 2 ft. apart; one piece 13 and one piece 14 ft. long. It is set upon stone pillars about 2 ft. deep beneath each post. The roof projects 15 in. The sides are of 9-in. shiplap.

Expense items are given by Mr. Cunningham as follows: 31,000 ft. stuff lumber at \$12.50, \$387.50; 6,000 ft. shiplap for siding at \$19, \$114; 8,000 ft. boards, flooring, etc., at \$18, \$144; 4,500 ft. sheeting at \$14, \$63; 36 M shingles laid at \$5.50, \$198; carpenters, \$346; foundation, 290 ft. at 10c., \$29; paint, 770 square yards at 15c., \$115.50; 19 windows at \$3, \$57; hardware, etc., \$46. Total, \$1,500.

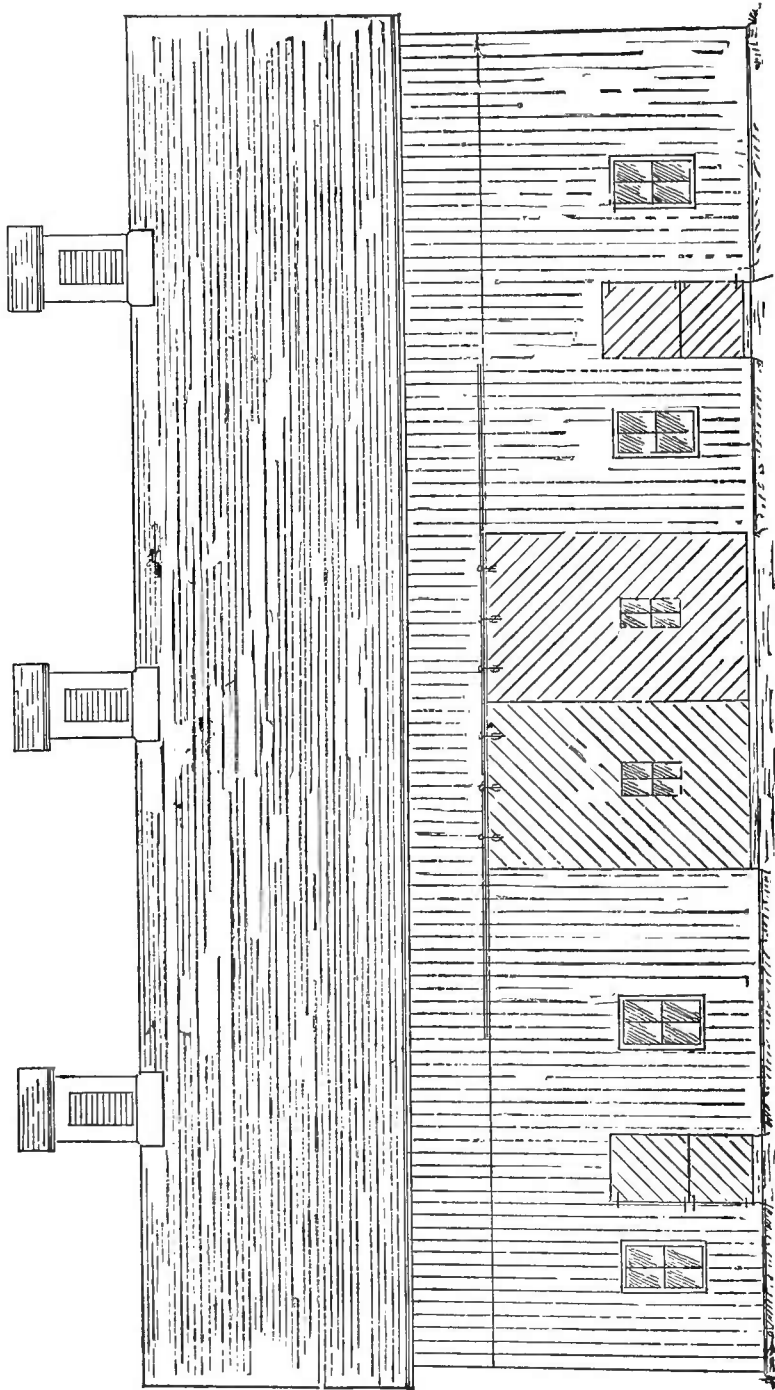

Scale 1/4" = 1' 0"
SIDE ELEVATION.

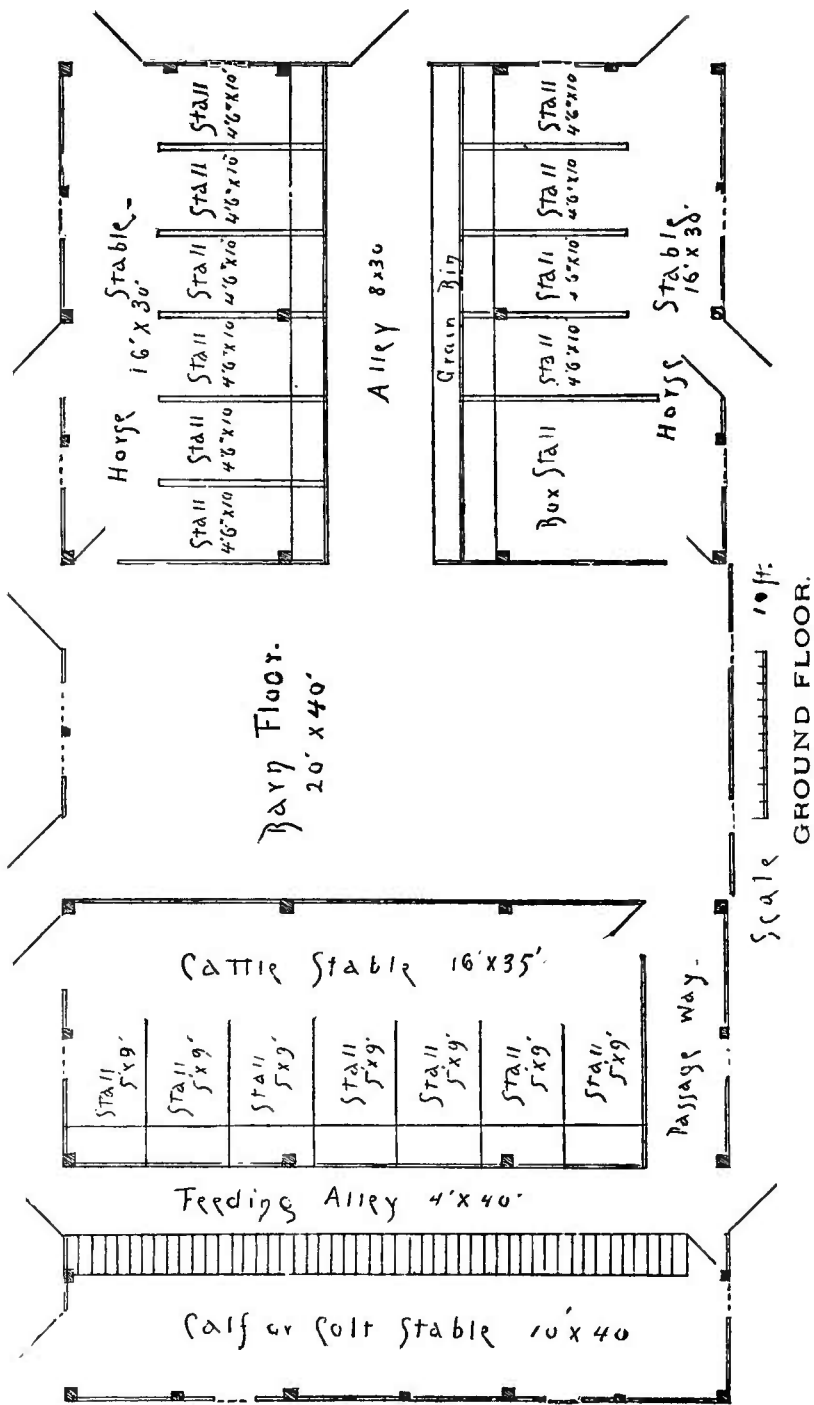

THE MILLER BARN AT GOODENOW, ILL.

The accompanying sketches represent a barn built on "the old Miller property" at Goodenow, Ill. It was designed and its construction superintended by the Hereford breeder and commission salesman, Mr. Tom Smith of Crete, Ill., and is especially noteworthy as being an eminently convenient, roomy and well-ventilated cattle barn, but of extremely simple construction and small cost. It will accommodate sixty to seventy head of cows and calves, having twenty-two

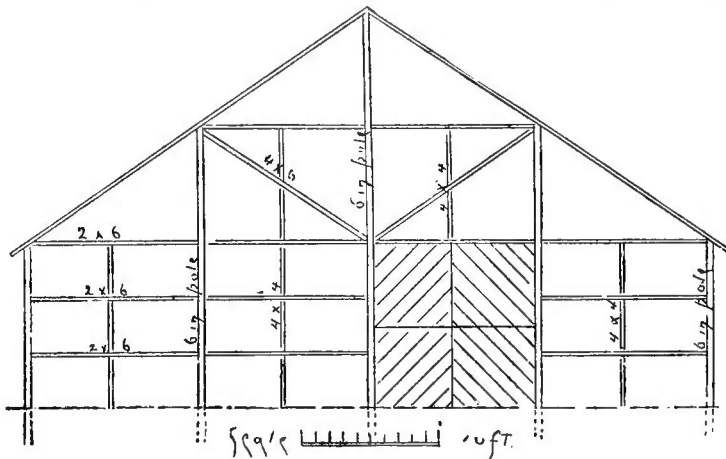

CROSS SECTION.

double stalls and six box-stalls, besides a roomy granary and hay floor at one end. Attention is called to the inside bay window in the bed-room of the office wing. This affords a most excellent view of the entire stableful of cattle.

The frame consists of common telegraph poles sunk into the ground and placed as shown in diagram, twelve feet high to eaves, and roof about one-third pitch. There are two sets of 2x6 nail ties and a 4x4 plate for rafters to rest upon. Four-light windows upon one side and double-hinged doors upon the other afford light and ventilation. The sides are common barn boards, planed, painted, and battened. The roof is of shingles and floor is dirt. A "brush drain" extending the length on both sides serves the double purpose of water conductor for roof and drain for interior. It

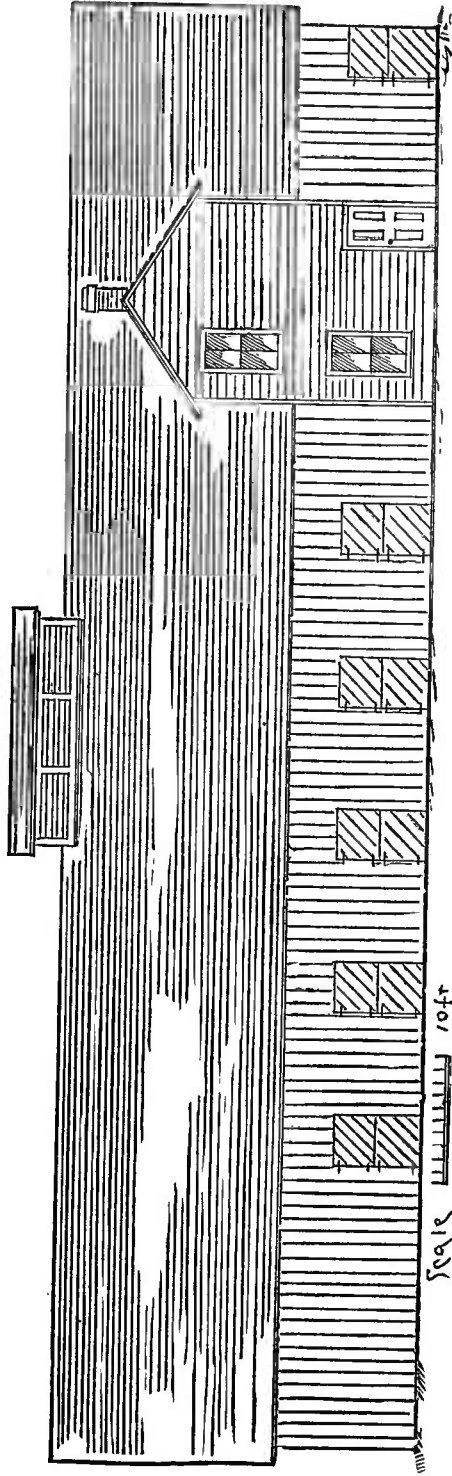

Scale 1/4" = 1'-0"

THE MILLER BARN—SIDE ELEVATION.

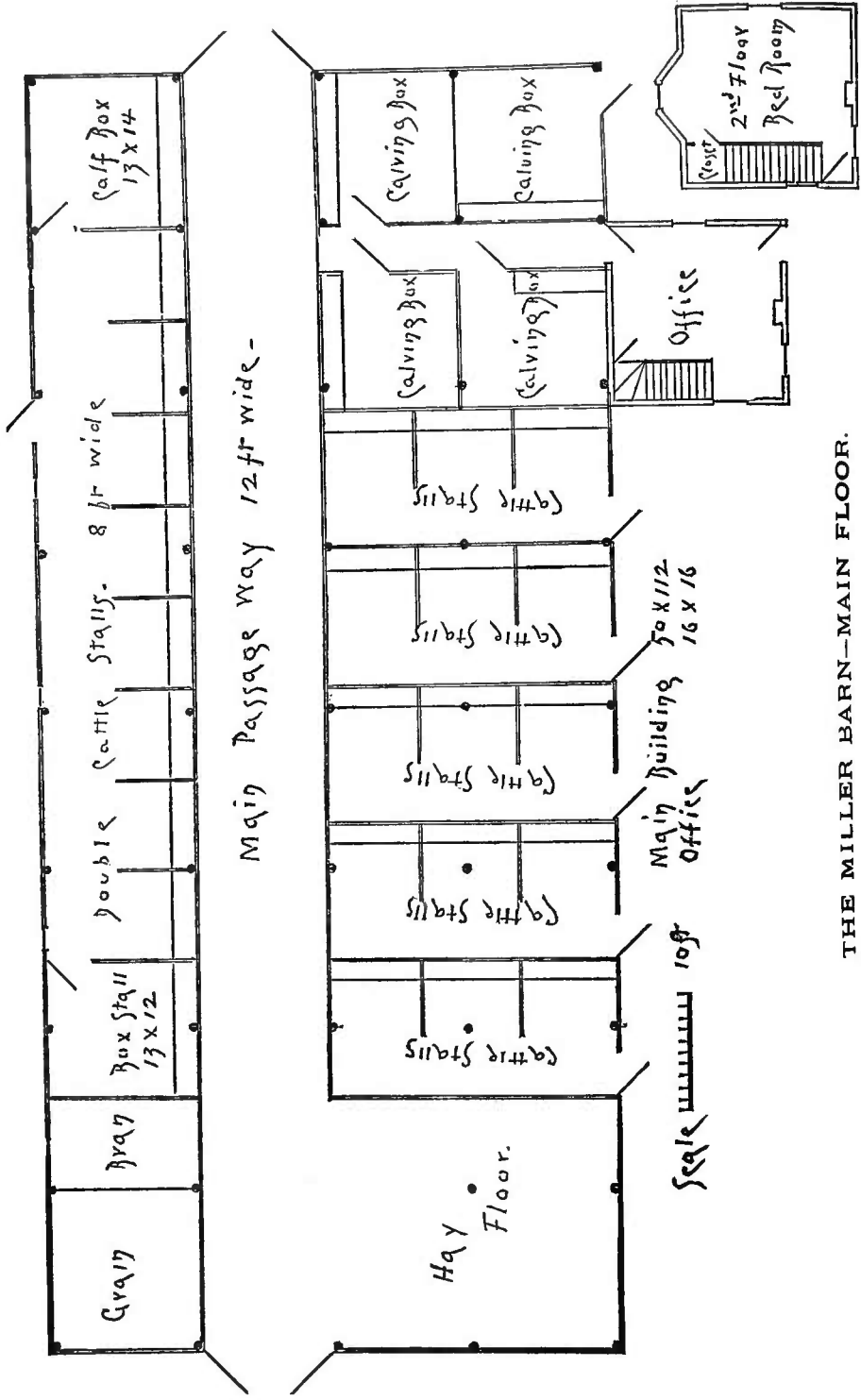

THE MILLER BARN—MAIN FLOOR.

is three and a half feet wide and two feet deep, and of course has a proper fall and outlet.

The partitions, alleys, stalls, boxes, etc., are all about three and a half to four feet high. There is no loft, the hay or fodder being hauled as needed, although the hay floor at end will hold quite a quantity.

Items of expense were as follows: Eighteen poles 15 ft. long, 18 poles 23 ft. long, 9 poles 32 ft. long, say \$35; 4,700 ft. siding at \$15, \$70.50; 5,100 ft. rafters at \$14, \$71.40; 7,000 ft. sheeting at 11 cents, \$77; 58,000 shingles at \$5, laid, \$290; 1,500 ft. stuff—nail ties, braces, etc., at 14 cents, \$21; five windows at \$1, \$5; 5,000 ft. partitions, stalls, mangers, etc., at 15 cents, \$75; paint, \$70; carpenters, \$185; hardware, etc., \$50.10; additional for office room, \$150. Total, \$1,100.

GEORGE E. BROWN & CO.'S BARN, AURORA, ILL.

The cattle barn in use upon the breeding farm of George E. Brown & Co., Aurora, Ill., is described as follows:

The frame of the cattle department consists of 2x6 studding 22 ft. high. There are two rows of posts and beams—without braces—along the center alley at each corner of stall (as shown in diagram) made of two pieces of 2x6 spiked together edge to side, and plates of same 2 in. apart and parallel. The joists of loft are laid upon these along the center and upon the two sides of the building upon pieces spiked to the studding, and as the joists are the same distance apart as the studding they may also be spiked to each other. The roof is supported by two sets of frame-work set upon the two rows of posts and beams along the alley.

The frame of the balance—the floor department, etc.—consists of 8x8 stuff with four rows of posts, etc., as in a common mortise and tenon frame. The cattle department is 7 ft. in the clear, and the balance is 8 ft. 2 in. in the clear. The joists of loft are 2x8, 2 ft. apart; rafters 2x6, 2 ft. apart; floor, 2x10 plank; floor of loft, unplanned boards. The sides are of 12-in. planed boards, with cracks battened. Roof should be about four-tenths pitch.

The cook-room and root cellar are basement rooms 5 ft. lower than main floor, 8½ ft. in the clear, and there are large grain and meal bins above these.

The doors into root cellar are 3x3. There is a large grain box below the floor under trap door, into which oats and other grain may be dumped and thence taken to bins in loft by means of an elevator. There are chutes from these by which it can be tapped as needed.

The tread-horse power is sunk below the floor, so that there is no trouble or danger in putting on or taking off the horses.

The feed-cutter, etc., are on loft floor just above the horse power, and the cut feed falls into the bin below. There are large hay doors at each gable sliding down, and a window on either side.

The estimated cost of the barn is as follows: Excavating 160 yards, at 25 cents, \$40; 98½ perch stone foundation, at \$1.50, \$147.38; 37,000 ft. stuff lumber, at \$14, \$518; 2,500 ft. matched boards, at \$20, \$50; 8,000 ft. boards for loft floor, stalls, etc., at \$16, \$128; 8,000 ft. of siding, at \$18, \$144; 8,000 ft. battens, at \$4, \$32; 7,500 ft. sheeting, at \$12, \$90; 57 M shingles, laid, at \$5, \$285; carpenters, say \$500; paint, 944 square yards at 15 cents, \$141.60; hardware, glass, etc., \$122.02. Total, \$2,198.

J. N. LEE'S CATTLE AND HORSE BARN.

Mr. J. N. Lee of Vigo Co., Ind., sends the following concerning the barn in use on his farm:

This structure was built in the summer of 1885 at a cost of \$3,000 for the purpose of accommodating our herd of Short-horn cattle and other farm stock, and in it we can hold nearly one hundred head of stock. It is 84x62 ft. with 24-ft. posts. Over 25,000 brick were used in the foundation, which is 16 in. at the bottom and diminishes until it is 8 in. broad at the top. The frame is of 8-in. timber. Sixteen feet off of the width (62 ft.) is a shed, as shown in the end view, built thus for convenience of light and tying the building, as

ties 62 ft. long are difficult to obtain. It is enclosed with barn siding and the cracks are striped with concave battens. It is roofed with gauge shingles (poplar) and the roof and sides are painted red with the battens white. The lower floor is oak, $1\frac{1}{2}$ in. in thickness. We think it will last better than a double floor of 1-in. lumber. It is 8 ft. between floors, the floor of the mow being of matched flooring. It is ventilated from below by means of tight boxes made from boards 1 ft. wide and extending through the mow to the roof. Hay chutes (4x6 ft.) are directly above the junction of the feed-

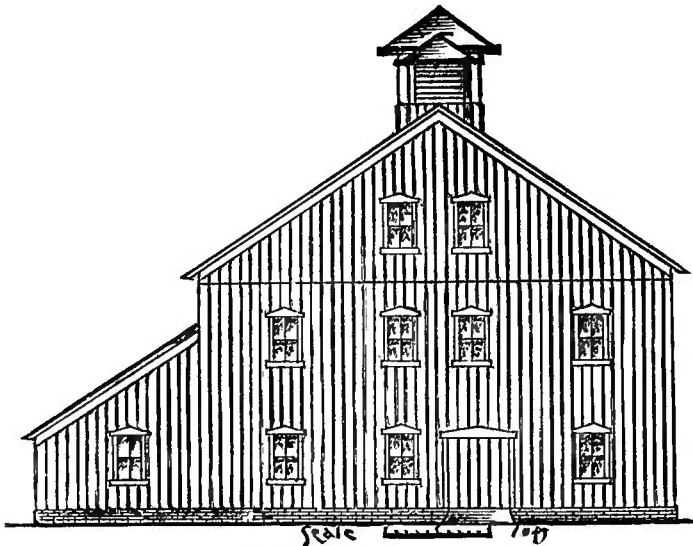

END ELEVATION.

ways and main passage, extending to near the top of mow. All bins, rooms, etc., are in the east end, so arranged that the stock in hot weather may catch the refreshing breezes as they come from the Southwest or West. As the driveway is in use but once a year we utilize this space by means of box-stalls. This is accomplished by the use of doors, which open as indicated in the plan. We set our mangers (which are fastened with hooks and staples) to one side, and are ready for harvest.

A space of 14x14 ft. is left in the drive as a place to curry and harness; and from this place, by opening a pair of drop doors, the hay is taken to the mow with fork and dead-lock

SIDE ELEVATION.

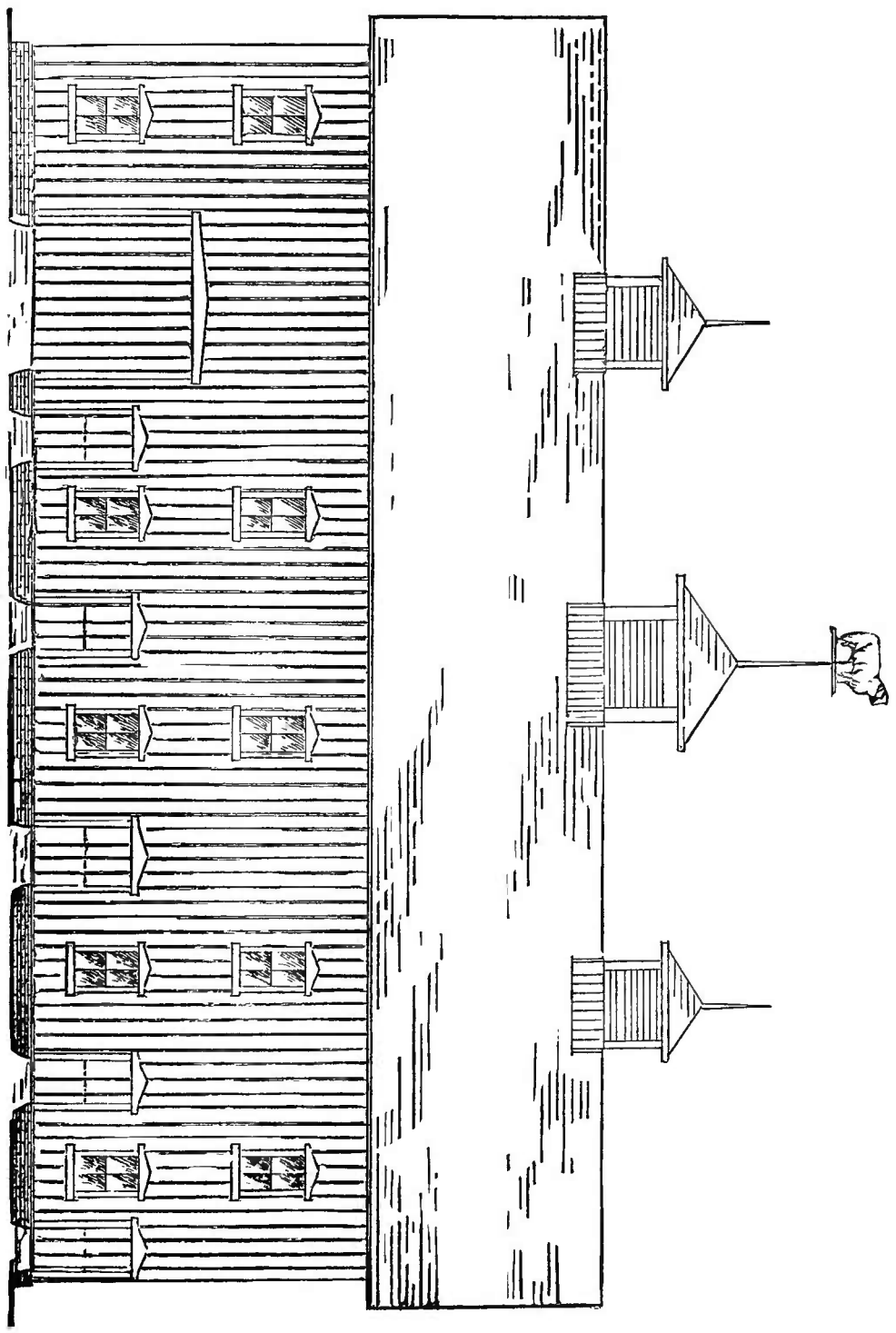

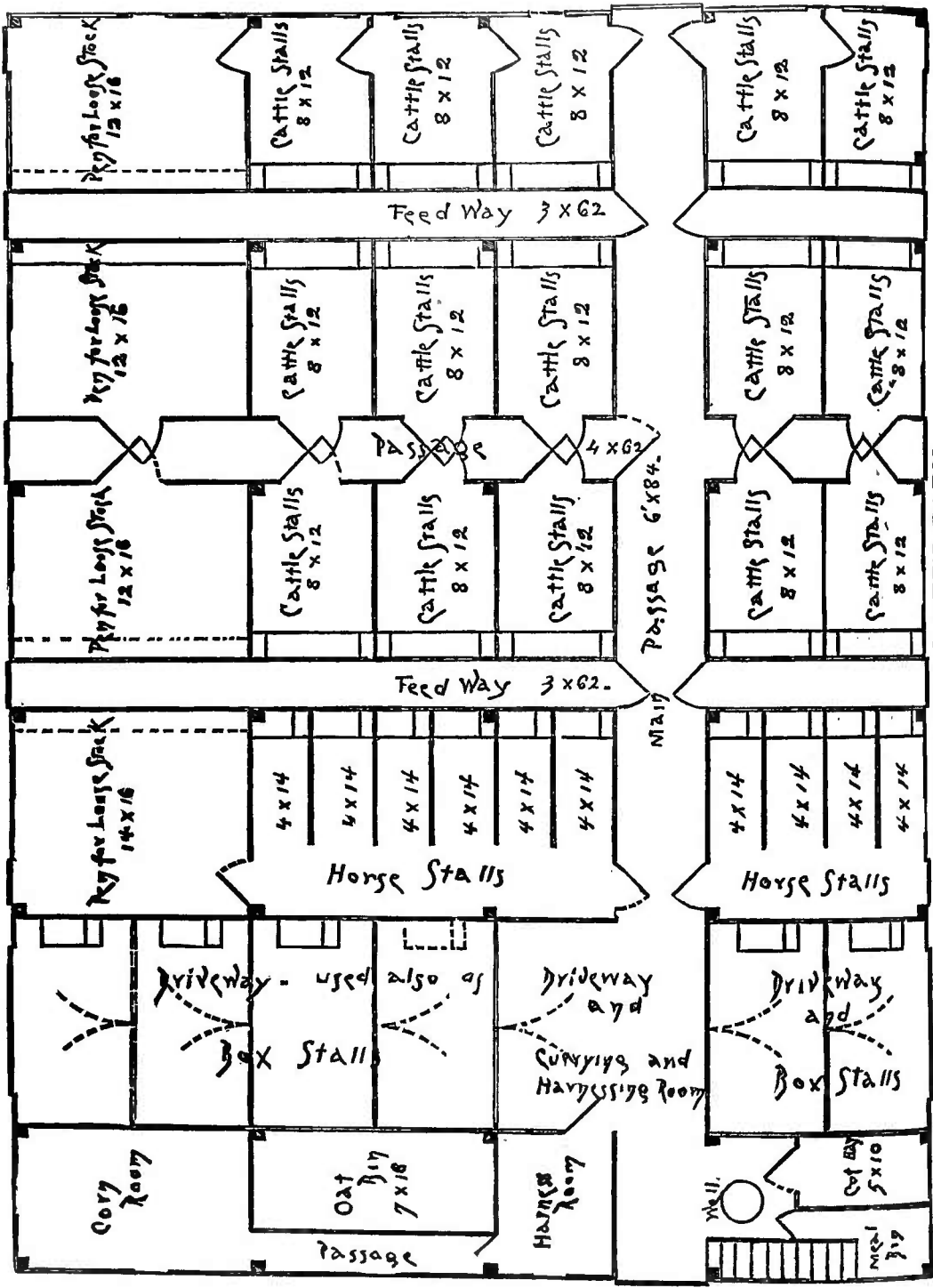

GROUND PLAN-LEE'S BARN.

carrier. A glance at the plan will show where the well, stairway, etc., are located, as also the length, width, and position of the stalls. The stalls are 3 ft. 6 in. high, with a kind of lattice-work between them so high that stock cannot fight over it. The feed-boxes are at the end of the mangers, as seen in plan. The cattle stalls are double, and the cattle are haltered at each side of the stall. There are four pens for loose stock. Doors are shown by a break in the double lines, and how they swing by dotted lines. It will be seen they open so as to close the passage, so a cow cannot help but go where she is wanted. Outside doors are shown in the plan to be at each feedway and passage.

CHARLES F. MOORE'S BARN, ST. CLAIR, MICH.

Mr. Charles F. Moore of St. Clair, Mich., has recently built a very complete stock barn as follows:

It is 40x152 ft., with a 16-ft. floor in the center. Hay carriers from floor to either end—all hay and grain unloaded by horses—16 box-stalls at one end and 36 stalls at the other, 12 of which are for young stock. There is a water box for each two stalls, so all cattle in this part can drink as they please. Water furnished by the St. Clair City Water-Works.

The entire barn is sheathed inside and out with matched pine lumber. Paper outside, then clapboards. The elevation is 8 ft., floor to ceiling, and 12 ft. loft, floor to plate, making about a 22-ft. elevation. Roof about one-third pitch. Windows are 24x44 in. at one end and 24x72 in. at the other. There is a door at each gable 48x72 in.

The windows have blinds, hung slanting, bottom out, so that when closed and the windows taken out, which is done in hot weather, there is fine ventilation and the barn keeps cool and dark, so flies cause no annoyance. The body of the barn is painted white and blinds green. It will hold about 200 tons of hay and from 50 to 75 head of cattle, and Mr. Moore considers it very nearly perfect.

The estimated cost is as follows: 528 cubic feet foundation pillars, at 10 cents, \$52.80; 46,000 ft. stuff lumber, at \$14,

\$644; 12,600 ft. matched siding, at \$18, \$226.80; 6,500 ft. matched flooring for loft, at \$19, \$123.50; 7,500 ft. boards for stalls, etc., at \$16, \$120; 8,000 ft. roof sheeting, at \$12, \$96; 60 M shingles, laid, at \$5, \$300; 15 windows, at \$3, \$45; 20 windows, at \$2, \$40; 1,056 square yards paint, at 15 cents, \$158.40; carpenters, \$609; hardware, paper, etc., \$84.50. Total, \$2,500.

THE LUTHER ADAMS BARN.

Mr. Luther Adams of Boston, Mass., who laid out an extensive farm near Storm Lake, Buena Vista Co., Ia., furnishes us the following description of the main cattle barn:

The great objects I kept in view in building this barn were economy in labor of handling, with due regard to health and comfort of the stock in a cold climate, no expense being spared to make it warm and comfortable in cold weather. The main body of the barn is 200 ft. long by 44 ft. wide, with a 14-ft. "lean-to" on either side. For 60 ft. on each end there are 18-ft. posts, above wall, with 80 ft. in center 24-ft. posts. The basement walls are 18 in. thick, 7 ft. high, built of quarried stone laid in mortar. The cellar is 200 ft. by 56; the cellar bottom was covered with three inches of sand and then three inches of Milwaukee cement. Sixty feet in one end is partitioned off for a root cellar; the balance of the cellar is used for steers and hogs, which run in and out at will.

The difference in the length of the posts of this barn was partially a matter of necessity, as I had an old barn to build on to that was 60 ft. long and with only 18-ft. posts. As I wanted more storage capacity than I could get in a barn with only 18-ft. posts my architect suggested the idea of making 80 ft. in the center with 24-ft. posts, and 60 ft. on the other end only 18-ft. posts, to correspond with the old barn and give the whole structure a uniform appearance. I was pleased with the idea and adopted it at once, as it makes a much better looking barn outside than it would have been if the roof was at the same height the entire length; it

breaks up that ropewalk look which so long a barn always has. If I had the entire structure to build over I should make only one change, in this climate, where large storage capacity is convenient. I would add two feet to the posts all round, making the ends 20 ft. and the center span 26 ft. high. Where the hay is elevated by horse power it is just as convenient to have a high mow.

The storage capacity for hay is about 300 tons, and it will accommodate about 175 cattle, old and young, exclusive of the cellar.

The two lean-tos tie up 100 head, with from three to four feet of space allowed for each animal, the stock being graded according to size, four feet being allowed in one lean-to and three to three and one-half in the other. I tie with chains for the greater comfort of the cattle.

The box-stalls are 10x14 ft. and are used for the breeding cows and young things, and will accommodate about seventy-five head.

The distance between lean-to floor and hay floor above is $6\frac{1}{2}$ ft. and over the driveway floor it is 14 ft. for 60 ft. at each end, but 80 ft. in the middle is dropped down to $11\frac{1}{2}$ ft. The pitch-holes over the driveway are in the fifth bent from each end; the driveway is 12 ft. wide and lean-tos 16 ft.

It requires but little labor to take care of the manure in this barn; it is cleaned into the gutters behind the cattle, and shoved to the traps and dropped into carts set to receive it, which are removed as often as they are filled, and the manure dumped into a pile to be overhauled and rotted, when it is used as a top dressing for meadow and pasture lands.

I have endeavored to make the water-works in this barn and yards as near perfect as possible. I have adopted the elevated railroad tank as a source of supply. The supply and delivery pipes are made frost-proof on the railroad plan of tight dead-air spaces, by being boxed in with eight coverings of matched boards and tarred paper, leaving a dead-air space between each covering. I am assured by good authority that this is sufficient protection to the pipes in northwestern Iowa if the tank is not allowed to run down too low. To

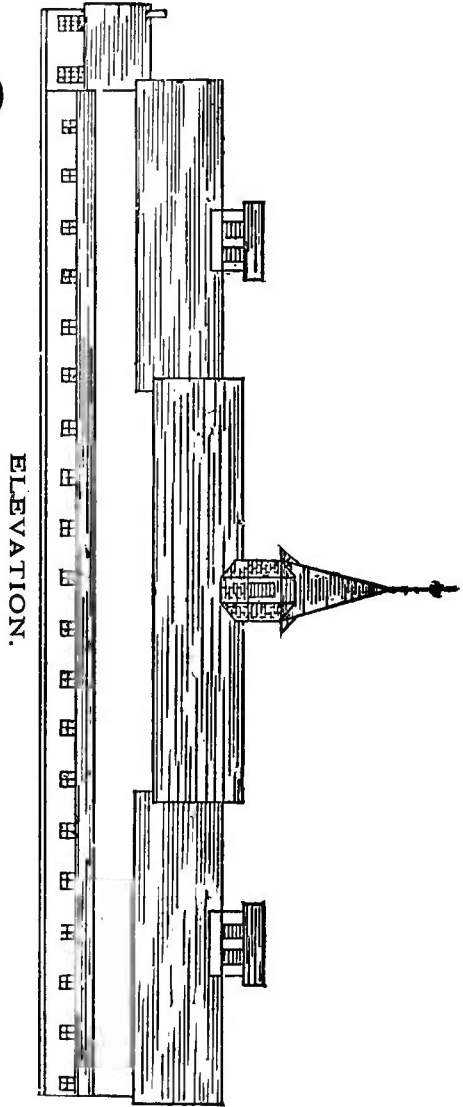
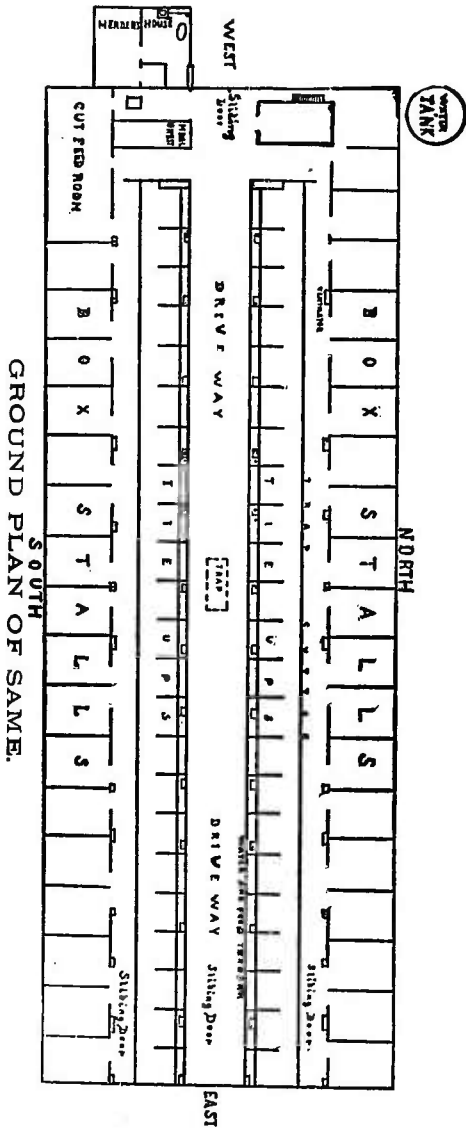

guard against accidents I have connected the tank with two wells, and use windmills for power.

It will be seen in the plan that there are watering troughs the entire length in front of the lean-tos; these troughs are 18 in. wide, 8 in. deep, with 3-in. pitch to drain the water out through a 3-in. pipe to a cesspool. Where the pipe enters the trough it is provided with a plug and strainer to be used when the trough is filled and emptied. The trough is not kept full except when it is desirable to water the cattle, and it is designed more particularly for bad weather, and after using it is emptied and used as a feed trough for cut feed or grain. The cattle in the box-stalls are watered in bad weather from troughs at the north end of lean-tos, as will be noticed in plan.

It will also be noticed in plan that the room for cut hay, mixing room, meal room, and water are all close together;

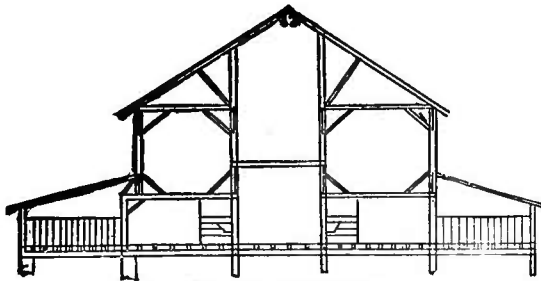

END SECTION.

the mixing troughs are set on wheels and are wheeled anywhere in the barn that is desired. The feed cutter is placed on the scaffold over and directly in front of the cut-hay room. The cut hay is dropped down into the room through a chute. The power is brought about 100 feet from the engine room by means of a chain cable. The two small rooms shown at the left end of ground plan are grain, meal, and feed rooms.

The herder's house, which is attached to the barn, is supplied with a hot-water boiler which is at all times ready for use. This house is a great convenience when cows are calving in the night or in cold or bad weather.

I have endeavored to make the root cellar frost proof; it has a double wall, dead-air space, and is banked on the north;

a wall and banked on the east and south with double windows, also a cross wall with double doors for entrance on the west. The floor over the cellar is double, with tarred paper between, then a three-inch dead-air space, then three inches Milwaukee cement.

The walls of the lower story are sheathed, also the ceiling over the box-stalls; the partitions in the box-stalls are of surfaced plank, tongued and grooved, and set on end and capped with four by sixes grooved. The mangers are also of plank.

All of the material used in this barn has been of the best. I have not tried to see how cheap, but how good, convenient, and practicable a barn I could build to handle cattle with the greatest economy of labor, with thrift and safety to the animals.

In this form of barn there is not a foot of waste room, and for a stock barn I believe it will bear a rigid comparison with any form of barn yet devised. I do not think that simply for storage of hay it would bear any comparison to a barn built on the octagon plan, but for a stock barn I prefer it. The whole building has been well painted, including the roof. Total cost, including herder's house, about \$13,000.

C. S. RICE'S BARN, DISCO, ILL.

Mr. C. S. Rice of Disco, Ill., in sending us the accompanying plan and description of his barn, says:

Allow me to present for the benefit of those who, like myself, have had no rich "dads" before them, and who, just commencing, must practice economy, with the plan of a cattle barn which I have just completed at a cost of \$700. I have endeavored in the diagram to make everything plain as to the plan, and it only remains to say how it is constructed.

I first placed forty posts in the ground upon which the building rests. These are arranged in four rows of ten each, as shown in the diagram. Upon each of these four rows of posts I spiked a 2x8 plank which has a mortise directly over each post in the ground. The frame then consists of four

rows of poles, which stand directly over these posts in the ground, each having a tenon to fit in the mortise above spoken of. The outside or eave rows are eighteen feet. The center rows are sixteen feet from the eave ones, and are about thirty feet long, extending up to form the purlines. Gains are then cut in these posts at top of first story, $2\frac{1}{2} \times 10$ in., to receive the four rows of girts. The same is done at the eave and at the top of purline save that these ties are only 2×8 and have a 2×4 spiked upon the top to give greater strength. On top of these girts are laid the joists, two feet

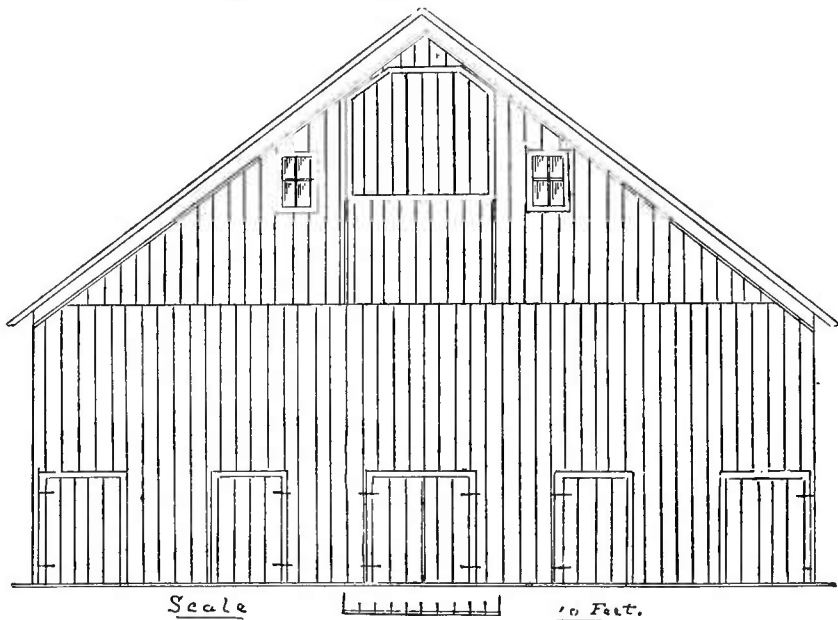

END ELEVATION.

apart, and each one that comes to the post is securely bolted, so that the building cannot possibly spread. The building is tied at the eave in the same way, only that here it is only every sixteen feet.

It is then raftered, and so on, the same as any other barn. A tight floor is laid in the mow, and braces are placed wherever it was thought they were needed. It is sided with dressed siding, completely battened and nicely painted, and makes as handsome an appearance as any barn in the country, and for convenience it has, I believe, no superior. One

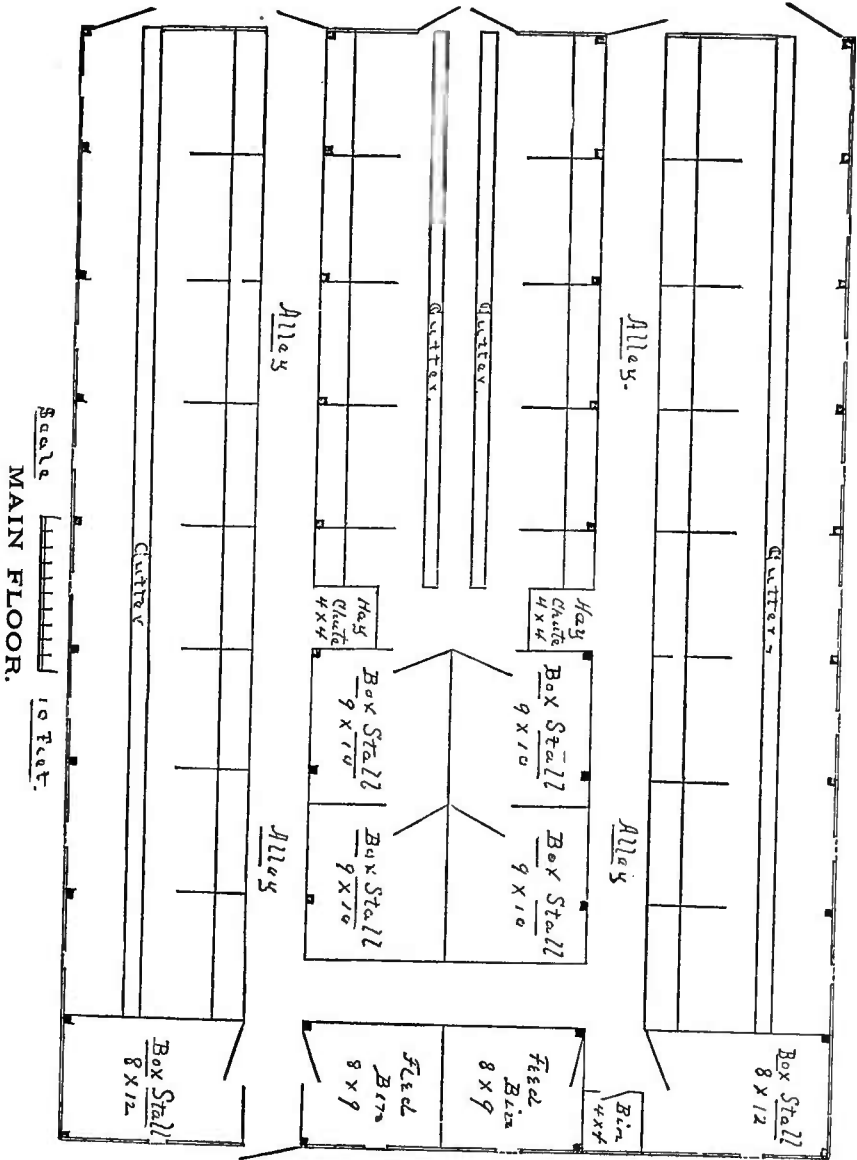

man (which is all I keep) can in a very short time bed and feed every animal in the 240 ft. of stabling. The stalls are not floored, but a tight floor is laid in all the entries. Each bin, it will be seen, is independent of the other. I wish to call attention to the hay holes. These are 4x4 and are simply boxes running from the eaves to the floor in the feed alley—save the doors in the mow to throw in the hay—and they are open from the mow down on the side that opens to the feed alley; also to the places over each stable, which are boxed above the same as the hay holes to allow the straw to drop for bedding. My girts and joists were all of the best seasoned oak. The building seems perfectly firm and is pronounced a success by every one who sees it. I used over five hundred $\frac{1}{2}$ -in. bolts in its construction.

ANOTHER ILLINOIS BARN.

The barn illustrated herewith was designed by Mr. V Barber of Decatur, and is located on the Macon County (Ill.) Poor Farm. The main feature in its construction appears to be the immense storage capacity afforded for hay and straw,

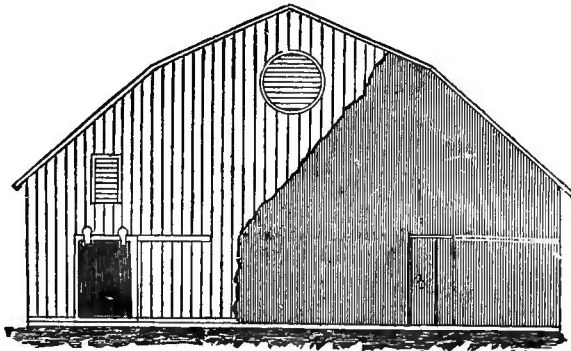

END SECTION.

and in view of the vast quantity of forage of that description wasted annually from lack of protection from the inclement weather the question arises as to whether or not more attention should not be given to that subject in the construction of barns.

Mr. Barber's plan indicates a barn 50x70 ft., with cattle

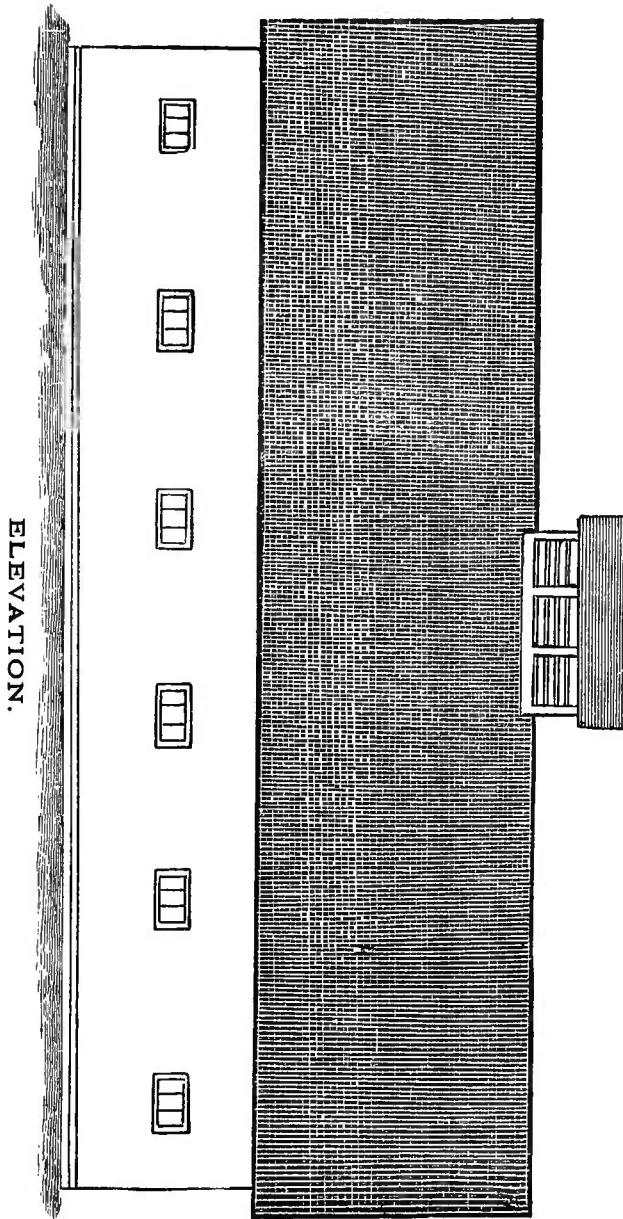

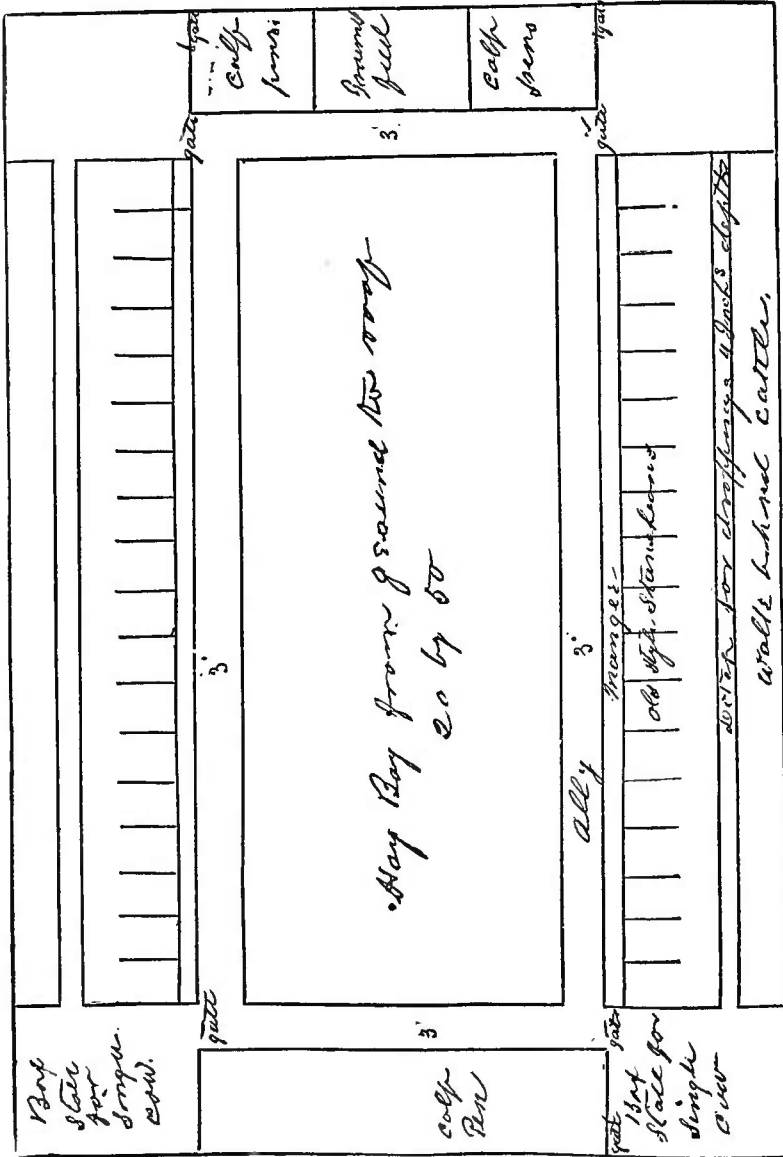

GROUND FLOOR—BARBER'S PLAN.

stalls and a three-foot alley on each side, the central space and entire area above the stalls being devoted to the mowing of hay and straw. The "end section" (page 90) is intended to show this arrangement.

There are doors at the rear end of the barn the same as in front, and over the main doors in the rear are two smaller doors wide enough to admit the straw carrier of a threshing machine, so that when threshing the machine dumps the straw into the loft of the barn over the stack on either or both sides by moving the machine. There is also a large door 10x9 ft. for taking hay from the load by the horse hay forks on track running the entire length of the comb of the barn, hauled up by horse at the other end of the barn.

Material of the following description is used: Sills, 6x8; joists, 2x8; corner posts, 6x6; other posts, 4x6; braces, 4x4; girts, 2x4; plates, 4x6; rafters, 2x4; sheeting, second fencing; shingles, 18 in., best; siding, 12 in. stock boards; flooring, 2x8.

W. W. HAMILTON'S SALE AND CATTLE BARN, LEXINGTON, KY.

Mr. W. W. Hamilton of Lexington, Ky., had a combination sale and cattle barn built upon a plan which will doubtless be of interest to breeders of pedigreed stock who hold public sales. Those who make annual sales need a building of some kind for this purpose as there are many annoyances about a sale tent—getting it on the ground the day it is wanted, putting it up, taking it down, etc. The difficulty about the construction of such a building is the loss of space when not used for sale purposes and the proper arrangement of the stalls so as to be convenient and at the same time not to interfere with the sale plan. The building is 64 ft. wide and 80 long and 20 ft. to the eaves. There are two rows of box-stalls—one at each end—8x10 ft. square each; in the center of the barn is the sale square (56x60 ft.), and in the middle of this square is a sale ring 30 ft. in diameter. Between 500 and 600 persons can be seated comfortably. When not used for sale purposes the sale square is divided into four

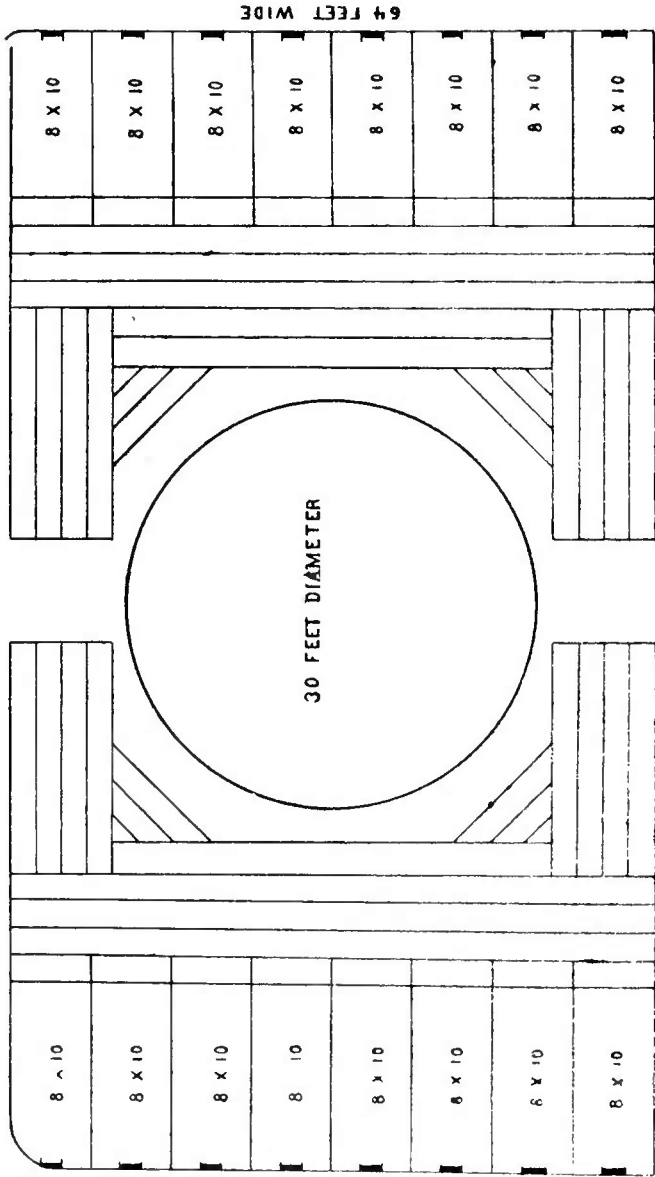

80 FEET LONG,
 64 FEET WIDE
 DIAGRAM SHOWING ARRANGEMENT FOR SALE.

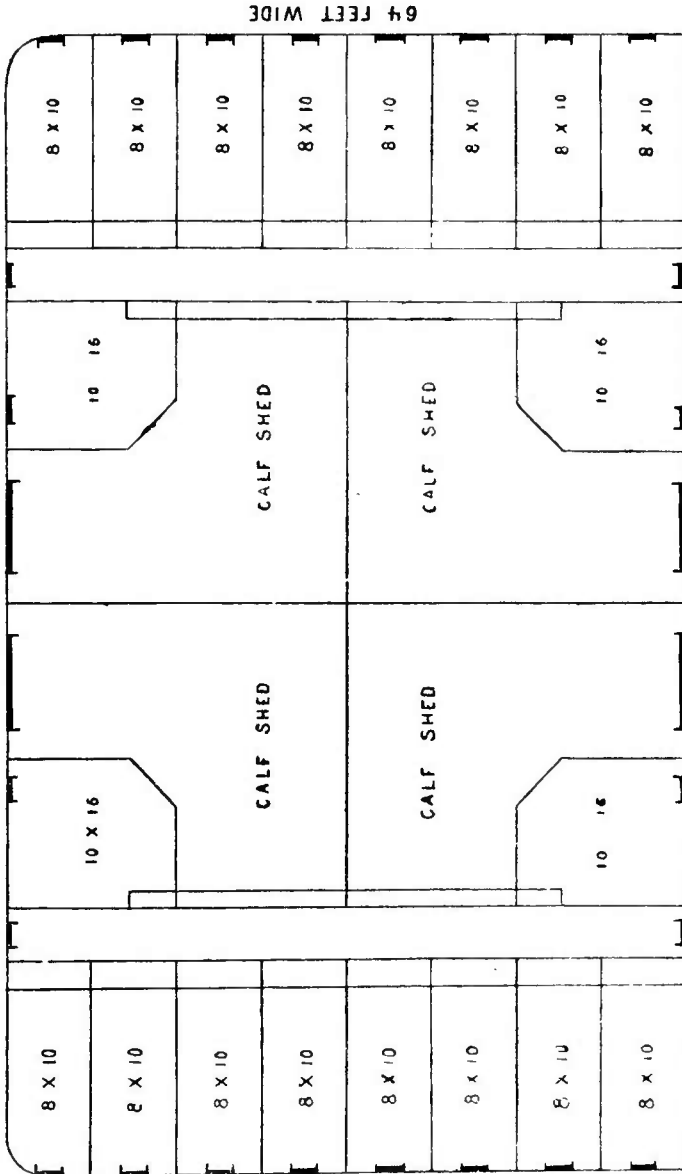

80 FEET LONG
SAME ARRANGED FOR ORDINARY USE.

large calf sheds, with a capacity of twelve head each, all of which will be readily understood by reference to the accompanying diagrams. There are two passways (4 ft. wide each) between the large square and the rows of box-stalls. There are four large box-stalls in the corners of the large square; two are used for calving and two for large bulls. The height of the ceiling over the large square and two passways is 12 ft. and over the rows of box-stalls 8 ft. There are two corn cribs and chop-feed rooms over the stalls at each end of the building, capable of holding 3,000 bushels of feed, with chutes to drop the grain in receivers in each passageway; also capacity for 100 tons of hay. Every animal in the stable is fed from the passageways. Each stall has a door opening outside for use in case of fire. This plan was drawn by Mr. Hamilton himself, and it forms a strong, comfortable, and convenient building, with plenty of light and ventilation at all times. The heavy framing timbers are of oak; the boxing is poplar; the foundation is stone laid in mortar.

T. S. MOBERLEY'S BARN, RICHMOND, KY.

A general description and plan is herewith given of the barn of Col. T. S. Moberley of Richmond, Ky. As will be seen by the elevation it is a bank barn and stands upon high ground where the natural drainage is good. The size is 62x74 ft. and from basement floor to the wind-engine tower the height is 56 ft., divided into four stories. The basement wall is of limestone, 22 in. wide and 8 ft. high, and the posts in the basement supporting the frame work are twenty in number and are of oak, 12x12 in. The parts of the frame are 10x10 in., 16 ft. high. The entire frame work is of oak, the shingles of poplar, and the siding of Northern pine. There were used in the structure 100,000 ft. of lumber and 50,000 shingles, and the total cost was about \$3,900, but at the time it was built prices of both labor and material were much higher than now. The diagrams of basement and main floor are quite complete and need but little explanation. There are two feed aisles, with a cross aisle and forty box-stalls for

grown animals, and the cross or calf aisle will accommodate fifty calves. The feed descends through a chute from the third story and two cars await to carry it down the aisles, along which it is distributed to the stalls. The columns in the second story, which extend upward and also form the third story, are thirty-six in number and 10x10 in. in size. The floor of this story is double, with pitched felt between, which protects the animals below from the ones above. This floor is inclined each way from the center sufficiently to

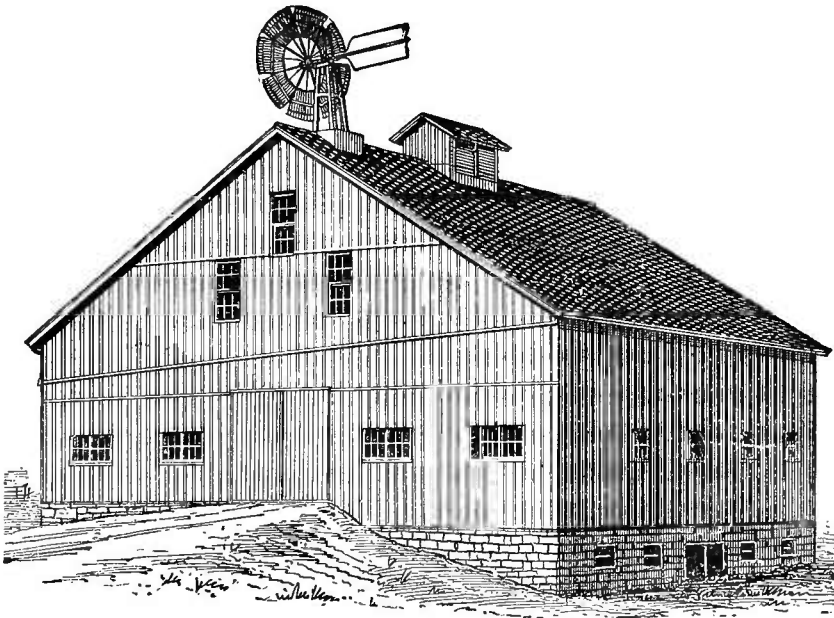

ELEVATION.

cause proper drainage. The entrance to this story is through double doors, fourteen feet high, via an elevated macadamized drive extending outward from each. Scales are placed at one door, so that the grain is weighed by the wagon load as it is taken into the barn. The wagon passes along the aisle and out at the opposite door. A gigantic hay-lift reaches down from above, takes up a load of hay and puts it in any desired part of the third and fourth stories or hay loft, which loft has a capacity of 500 bales. The second story has fourteen calving stalls, as shown in diagram, which are so arranged that they can readily be converted in case of

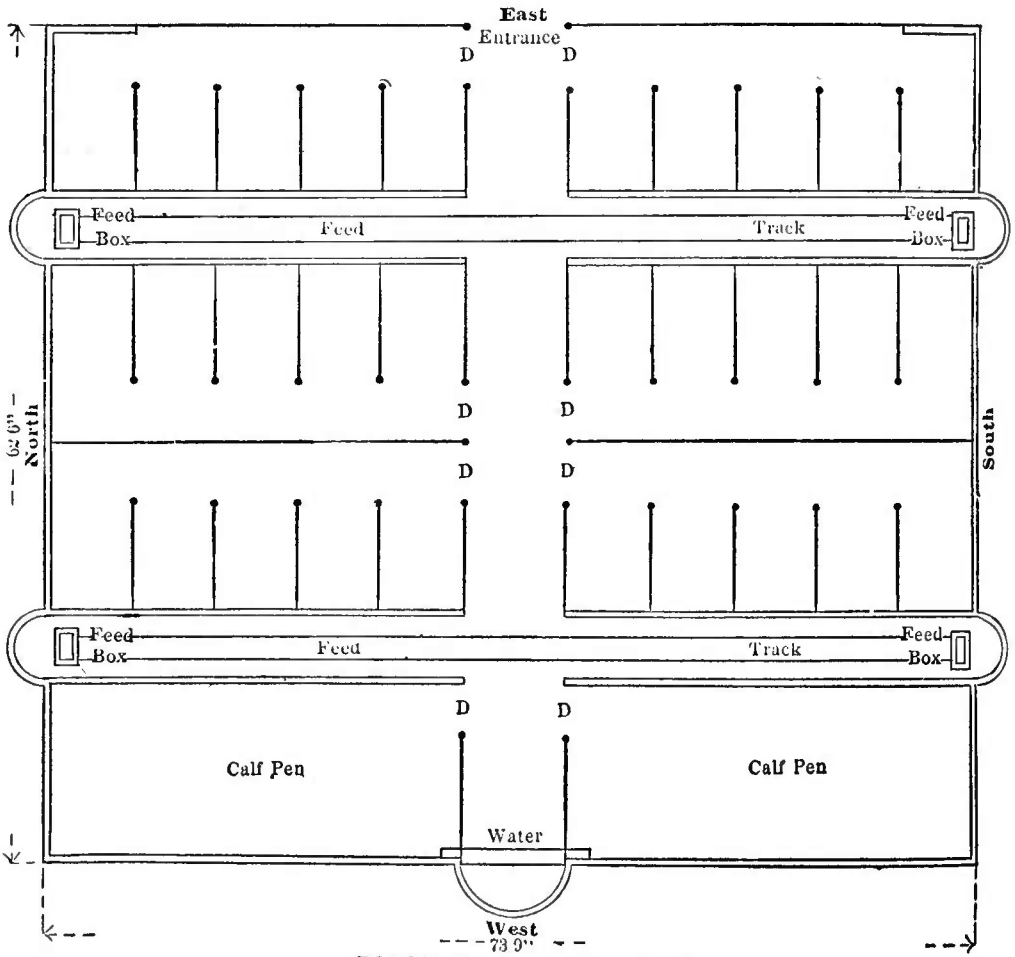

707

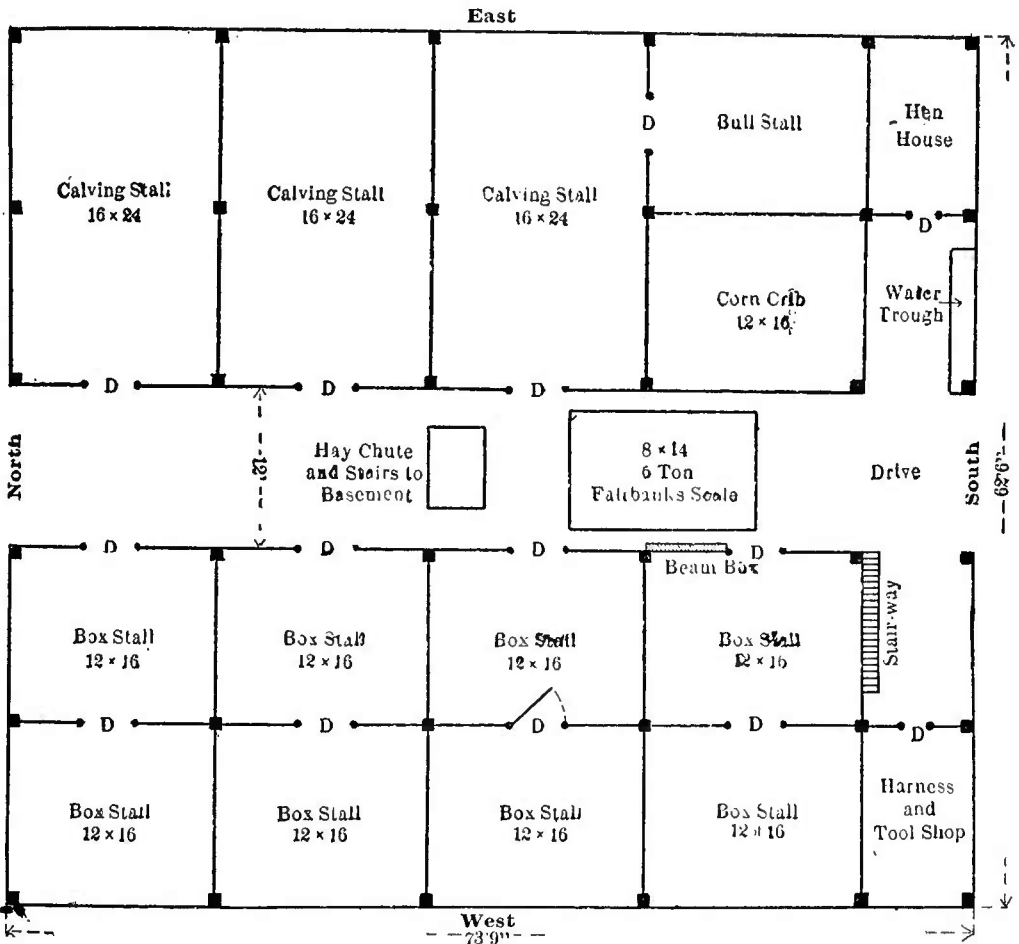

DIAGRAM OF MAIN FLOOR.

necessity into four stalls each, making room for fifty-six cows. In the center or main aisle, twelve feet wide, there is room for fifty calves.

This gives the barn a capacity of 196 animals, all sizes. Col. Moberley's office is also on the second floor. Just outside the building a cistern which holds 500 barrels furnishes the water for the entire building through a system of pipes. The third story contains the bran bin, corn boxes and cut-feed room; also the large cutting box, the corn sheller and the pumping machinery, which are driven by wind power. With a brisk wind a boy of twelve or fourteen years can cut enough grain in two hours to last a week or ten days; and so complete is the arrangement in every particular that one good man can easily feed, water and care for the stock and keep the barn in order.

C. E. KING'S DAIRY BARN.

The accompanying plan of barn for a dairy farm was designed by Prof. F. H. King of the Wisconsin Agricultural Experiment Station for Mr. C. E. King, a dairy farmer near Whitewater, Wis., and in its architecture as well as general plan may be profitably studied by intending builders in connection with the octagonal dairy barn of Messrs. Miller & Sibley (pages 53 to 57). The design herewith given was, as Prof. King informs us, "the result of a request for a plan of a barn for a dairy farm which would accommodate eighty cows and ten horses and which would permit of driving behind the cattle in cleaning and in front of them in feeding green fodder. A silo, a granary and storage space for dry fodder sufficient for all the animals was desired, and the whole was to be covered by the same roof, to be conveniently accessible in all its parts, but not very expensive"; and of its special features Prof. King writes as follows:

The plan of this barn is presented here, not as a novelty in rural architecture, but because in several fundamental features it embodies ideas which are believed to be worthy of general imitation, and this particular plan is used simply

as a concrete illustration of the character of improvements which at the present time are greatly needed to insure the highest development of a large and profitable animal husbandry in a climate of long cold winters.

It will conduce to clearness if the fundamental ideas referred to are stated concisely at the outset and then amplified and illustrated.

1. Whatever other advantages or disadvantages a shelter



Fig. 1.—Cylindrical barn, showing main entrances to first and second stories. From a photograph.

for live stock may possess, it should in no way interfere with the best performance of the animals housed.

2. The shelter should be so built that the heat necessarily given off by the bodies of animals housed shall be sufficient to maintain the best stable temperature during cold weather and at the same time admit of ample ventilation, while during warm weather the surplus heat may readily escape.

3. The construction should be such as to admit the needed amount of light to all the animals housed.

4. The construction of the shelter should be such as to

reduce the labor of caring for the animals to the smallest amount which will admit of the largest yearly net profit.

5. The form and arrangement of the buildings should be such as to necessitate the least first cost and the smallest maintenance expense compatible with the necessary accommodations.

A perspective view of the barn, from a photograph, is given in Fig. 1 (page 101), showing the main entrances to the two stories, while Figs. 2 and 3 are bird's-eye views of the interiors of the first and second stories designed to show the construction of the barn and the arrangement of its interior. It will be seen that in form the barn is cylindrical, covered with a conical roof which is surmounted by a cupola of the same form. The barn is 92 ft. in diameter and 28 ft. from sills to eaves. A cylindrical silo 24 ft. outside diameter and 34 ft. deep, having a capacity of 14,126 cu. ft., occupies the center. Around this silo in the first story ninety-eight adult cows are accommodated in two circular rows facing a common feeding alley 9 ft. wide, and behind each row of cattle is a wagon drive 6 ft. wide for cleaning the barn which leaves and returns to the common single broad entrance.

Extending entirely around the silo in the second story is a barn floor 18 ft. wide, from the outer edge of which, through chutes leading to the feeding alley in front of the cattle, green fodder can be delivered to them from the wagon or dry fodder from the storage space above. This floor also permits of driving around the silo and out at the entrance after unloading, even when the ensilage cutter is being run to fill the silo.

On the outside of the barn floor, on the right of the entrance, is stable room for ten horses, 16 ft. from front to rear, 34 ft. frontage on the barn floor and 55 ft. from end to end at the outside. On the left of the main entrance is a workshop and granary whose combined floor space equals that occupied by the horses. In the rear of the silo is a space 16 ft. deep for farm tools, having 32 ft. frontage on the barn floor and possessing a floor space the equivalent of 16x40 sq. ft. Between the tool room and the horse barn on one side and the granary on the other are two hay bays which, together

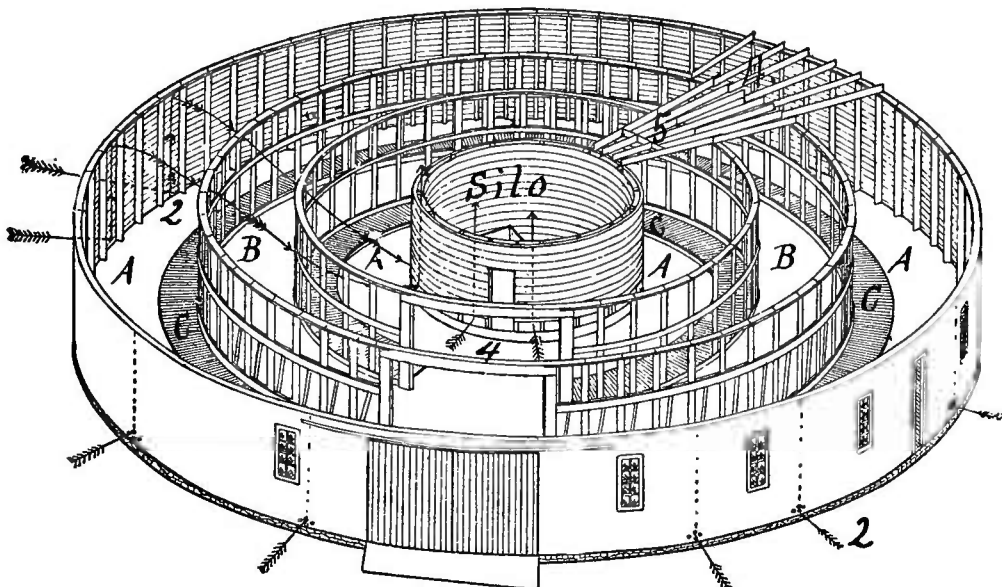

Fig. 2.—Showing arrangement and construction of first story. A, A, A, A, wagon drives for cleaning barn; B, B, feed manger; C, C, platform for cattle; 2, 2, 4, showing method of ventilation; 5, showing method of placing joists.

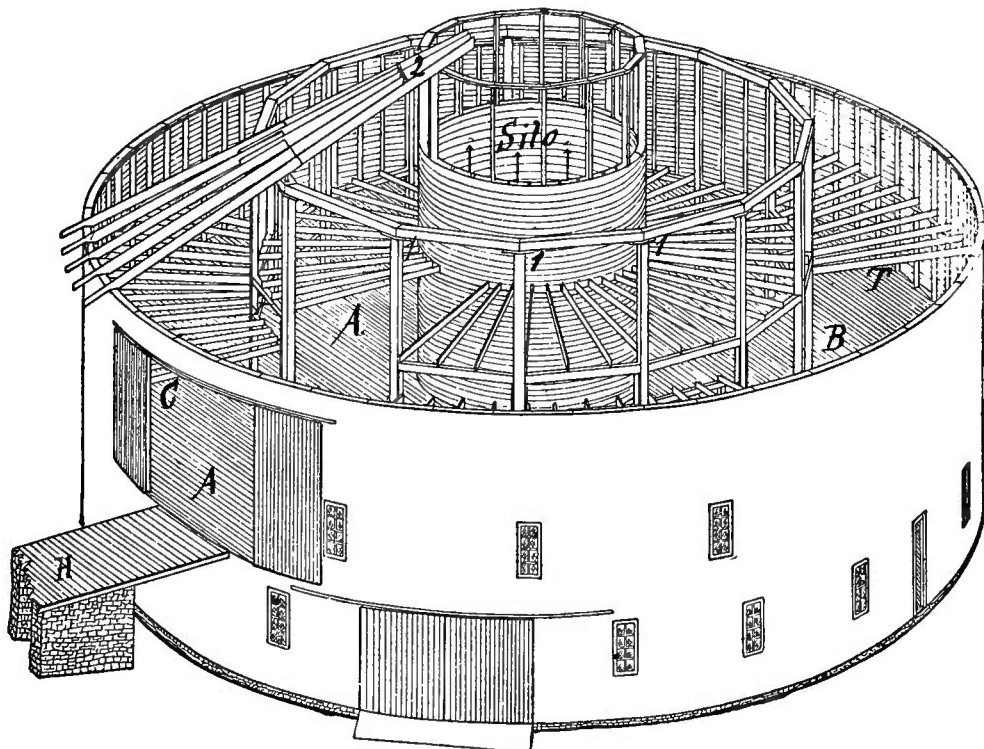

Fig. 3.—Showing arrangement and construction of second story. A, A, barn floor; B, hay bay; T, tool room; C, workshop and granary; 1, 1, purline plates and method of placing them; 2, 2, showing method of placing rafters; H, entrance drive.

with the space above the barn floor, tool room, granary, and horse barn, furnish ample storage space for dry fodder.

The silage is delivered to the cattle barn from the silo through a triangular chute shown in Fig. 2, extending up the inside of the silo; in one side of this chute there are doors and attached to the other is a fixed ladder by which any desired level in the silo may be reached.

The foundation of this barn consists of four concentric stone walls, the inner one carrying the walls of the silo and through them the central portion of the floors and roof, the two middle ones carrying the stationary uprights of the stanchions, and through them the floor, main posts, purline plates and roof, while the outer one supports the walls of the structure. The laying of the walls to a circle and leveling them was a simple matter and accomplished with the aid of a straight-edge, one end of which was fixed to a post in the center, with the lower edge at the level desired for the top of the walls. The movable end of the straight-edge rested on a ring of boards tacked to stakes driven in the ground outside the wall being built. The inner wall was first built and the straight-edge lengthened as necessary. The frame of the barn consists almost wholly of two-inch stock and the only long timbers are the eleven posts carrying the purline plates. No mortise and tenon work was used in its construction, all work being done with the hammer and saw. The first story sills of the barn are single 2x10-in. plank, sawed in 4-ft. sections and bedded in mortar on the walls, the sections having been sawed on a bevel determined by the direction of the radii of the barn. On the sills 2x10-in. studding are set 2 ft. apart and constitute the outer frame of the basement; 2x12-in. studs set flatwise on the two middle walls, at the right distance apart to serve as the uprights of the stanchions, and 2x12-in. studding in the walls of the silo, as shown in Fig. 2, constitute the vertical supports for the second story. The sills of the second story consist of short pieces of 2x10-in. plank spiked down upon the ends of the three outer circles of studding, as shown in Fig. 2, and of three thicknesses of 6-in. boards bent around the upper ends of the silo studding and resting on the shoulders sawed for

them. Two thicknesses of plank rest on the stanchion supports, but the outer sill is single; upon these 2x10 joists are distributed, as shown at 5, Fig. 2, and these carry the floor of the second story.

Each of the posts carrying the purline plates rests on four 2x10-in. joists spiked together and resting on the sills carried by the two rows of stanchions, the particular stanchion uprights where these posts come being strengthened by 2x6-in. studding spiked to them at the edge not occupied by the cows. On the tops of these posts short pieces of 2x10-in. plank are spiked, as shown at 1, 1, 1, Fig. 3, and upon them the purline plates rest, spikes being driven upward into them to hold them in place.

The rafters and studding for the second story are 2x6-in. stuff, the latter being set three feet apart, and the lower ends of the rafters are carried by two layers of 2x6-in. pieces spiked to the tops of the studding, the upper layer breaking joints with the lower. Fig. 3 shows the manner of placing the rafters.

The rafters were cut so that their ends when in place were vertical and the fascia was formed by springing a board to them. The lower one or two rows of roof board were sawed in short sections, reaching from rafter to rafter, and then fencing was used, full length, and sprung to the rafters over the remainder of the roof. It was not necessary to cut shingles in laying, except on the cupola, and in laying them each man was provided with a horse, made by driving spikes through one edge of a short piece of two-inch plank, which served as legs and prevented sliding. A mark was filed in the edge of the shingling hatchet at a distance from the nailing face equal to that which the shingles were laid to the weather, and this served as the only guide in placing them, which was done rapidly and readily, the men following one another round and round.

This barn is covered outside with drop siding sprung and nailed to the studding so as to break joints and on the inside of the cattle barn, horse barn and granary with shiplap.

In the construction of the silo, 2x6-in. studding was used above the basement, these being spiked side by side to form

the eleven long ones, which extend to and help support the roof. The lining of the silo consists of three layers of half-inch lumber, formed by ripping common fencing in two and between these are two layers of tarred paper. The same kind of lumber forms the outer covering of the silo and the spaces between the studding act as ventilating flues for the cattle barn.

The large doors slide open and are made of matched fencing nailed to cleats having the same curvature as the sides of the barn. These cleats are made by springing the boards into the desired curvature and then fastening them securely together while in that attitude. When this is done they remain bent as if they had grown in that form.

The feeding mangers in the cattle barns are made by forming the earth in the shape of a shallow, round-bottom trough in front of each row of cattle, raising the earth between them into a broad rounded ridge. This earth after being thoroughly firmed was plastered with a coat of water lime and has thus far proved very satisfactory.

Some advantages of the plan are: 1. *Effective Ventilation.*—When it is known that air once breathed, unless diluted with that which is fresh, cannot support higher animal life; that one-fifth of the weight of materials taken into our bodies daily is oxygen from the air, and that we must breathe 346 cubic feet of air to get it; that on the average our live stock consume more air per capita than we do, and that horses have died from suffocation while being shipped in box cars, it should be evident that, coupled with our efforts to secure warm barns, there should also be those to provide ample ventilation. The plan here described possesses a very simple, cheap, and effective method. It will be seen from Figs. 2 and 3 that the thirty-two spaces between the studs in the walls of the silo, being open at the floor of the cattle barn and also at the top, constitute so many ventilating flues, each 34 ft. in length. The heat given to these flues by the silage in the silo, the warming of the air in the basement by the cattle, and the suction produced by the wind blowing through and around the cupola, all combine to maintain a strong current of air out of the barn through the cupola and in through the

gangs of auger holes in the outer walls shown at 2, 2 in Fig. 2. It will be seen from the arrows in the cut that provision is made for fresh air to enter the barn from all sides, which, rising between the studding and flowing along the space between the joists, falls between the two rows of cattle, but is first mingled with the warmest air of the barn while the coldest and most impure air is constantly drawn out from along the floor. A very important feature in this method of ventilation is that pure air comes direct to all animals alike, while the impure air is drawn out in a uniform sheet all around the silo. It will be seen that this ventilation is secured without sensibly affecting the cost of the building, while at the same time the walls of the silo are kept dry and thereby protected from decay.

2. *Control of Temperature.*—The temperature of a barn whose plan of ventilation is the one here described is under as good control as is possible where artificial heat is not employed, because the cold air is introduced at the warmest part of the barn, while it is the coldest and most vitiated air in the barn which is being removed. Then when the barn is too warm the doors to the feed chutes may be opened, thus providing a direct escape of the over-heated air from the ceiling.

3. *Economy of Construction.*—The barn here described was built with lumber averaging about \$15 per thousand for a little less than \$2,400, including everything except board, or at the rate of \$22 per head for the animals it will shelter and store feed for; and this, when the driveways for cleaning the barn, the very large barn floor which admits of giving green feed to all of the animals from the wagon, the tool-room and the space which may be converted into three large box-stalls are considered, is relatively very cheap. The directions in which the economy occurred are these: By combining everything under the single roof, by adopting the cylindrical form, which requires the smallest amount of siding, roofing, and paint, and which admits of the cheapest and least lumber for the frame, and by distributing the lumber so as to make it perform two or more functions.

Another great advantage which the consolidated barn

possesses over several small, scattered structures, and especially where the feeding is done from a central point, as it is in the plan in question, is the large saving of time which it makes possible in feeding and caring for the animals.

The great economy of the circular plan for farm buildings over other types of structure diminishes as the size of the building decreases, but it is nevertheless well adapted to some of the smaller structures such as horse barns and sheep barns. In any case where an octagonal barn is desired the circular type will always be found cheaper and more stable.

Where a silo is to stand separate from other buildings there is no other type of structure which can be built so cheaply as the circular one, even if its diameter is not greater than 12 to 16 ft.

R. S. STEVENS' DAIRY STABLES, SILO AND DAIRY HOUSE.

Among the most complete, elaborate and conveniently-arranged dairy establishments in the United States is that of Mr. R. S. Stevens, near Attica, N. Y., a bird's-eye view of which is herewith given, together with a description of the method of construction and drawings illustrating the main barn as kindly furnished by Mr. Stevens for this work.

The main barn, which will readily be recognized in the illustration on page 110, is 40x125 ft., with 20-ft. posts and hip roof, framed and supported as shown in "Section through Barn," on page 111. The basement walls are of quarried stone and are two feet in thickness and eight feet high, plastered on the inside with Portland cement and painted a light color (almost white). A driveway runs the entire length of basement, on each side of which is a row of iron posts supporting the cross-sills above. The cows stand on each side of this driveway facing from it, with room enough in front of mangers to run feed-cart. The cattle are fastened with Newton's patent cow tie and there are no posts in basement except the iron ones above mentioned. Ventilators run from this basement along the sides of the

main posts of barn above and open under the eaves, giving good ventilation without draft. The basement is ceiled overhead with matched pine and painted white. All windows in basement are three feet square and hung so that they can be tipped at any angle desired.

The barn proper is divided as shown in the diagram herewith given: Two driveways, 14x40; one bay, 48x40, with 9-ft. granary along one side; one bay, 24x40, with covered passage from one driveway to the other (and which can be used as granary if desired), and one bay, 25x40. The driveways are floored with matched pine (2-in.) and the bays with same material 1½-in. All bins in granary have spouts leading to the basement.

The frame is of hemlock (sawed); sills, 10x12; joists, 3x12; beams, 10x10; outside posts, 10x10; inside posts, purline posts and beams, 8x8; plates, 8x10; braces, 4x4; rafters, 2x6. All barns on the farm are sided with pine boards twelve inches wide (dressed) and battens of the same three inches wide with edges beveled, and all painted a light drab (almost white). The roofs are all of the best pine shingles (sawed). Roofs are all painted with a fire-proof paint (reddish brown in color).

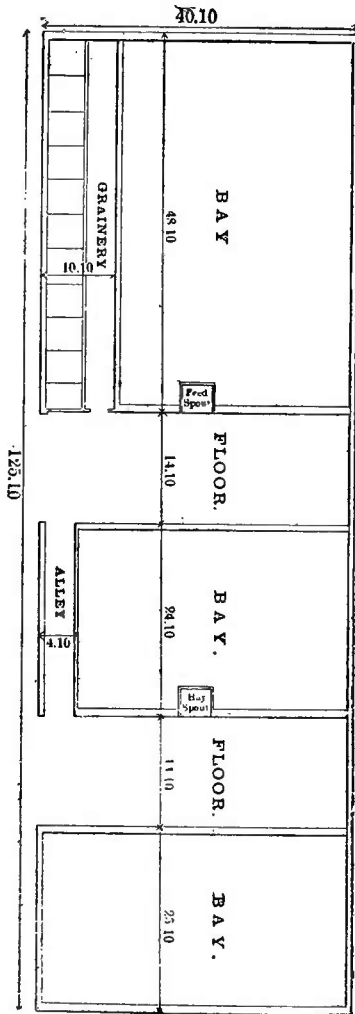

The other principal barn is 30x100, with 20-ft. posts and hip roof, material same as that above described, but without basement. The stables are above ground and arranged same as in No. 1. All the barns have tracks for horse-fork

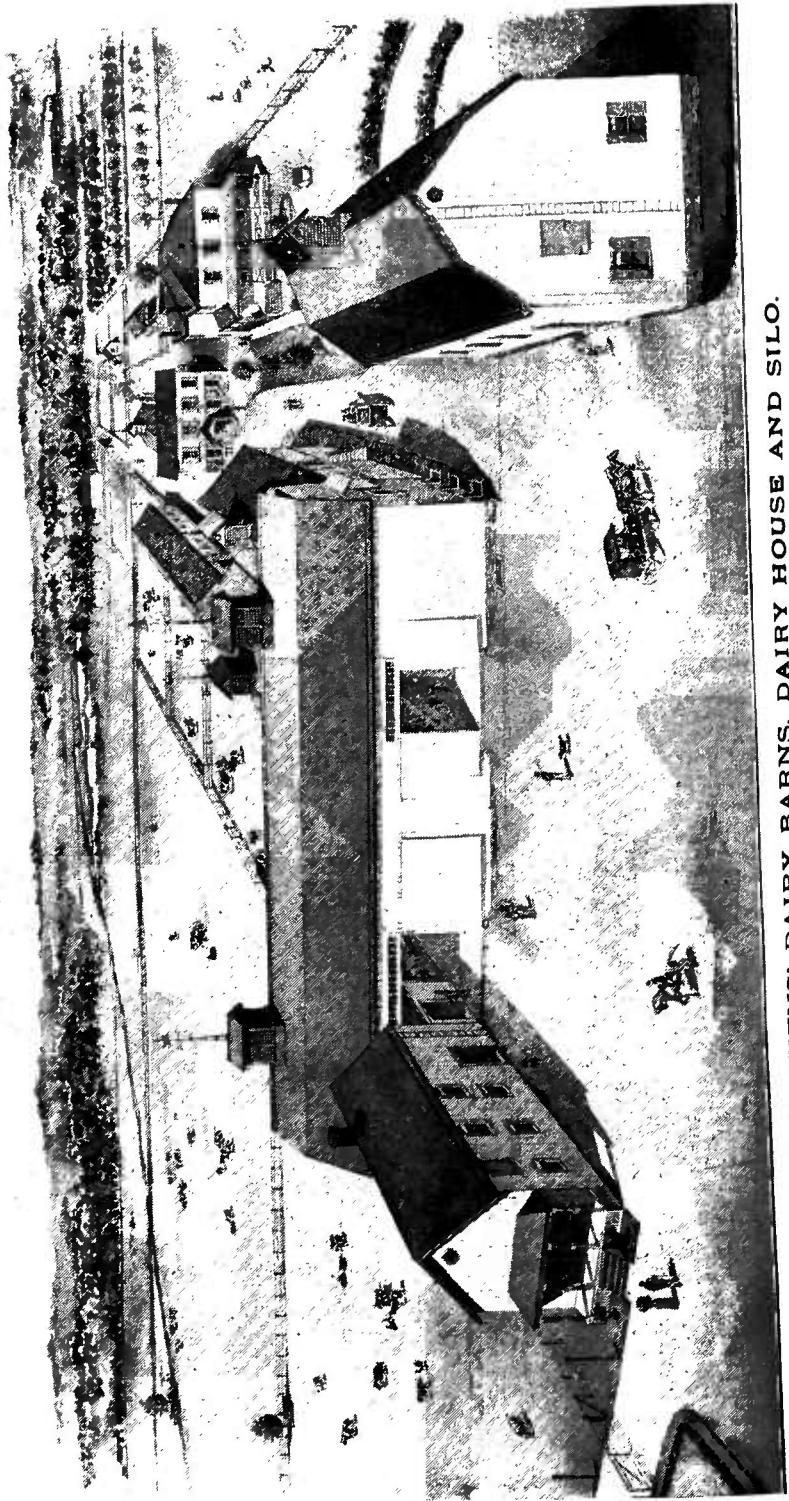

R. S. STEVENS' DAIRY BARN, DAIRY HOUSE AND SILO.

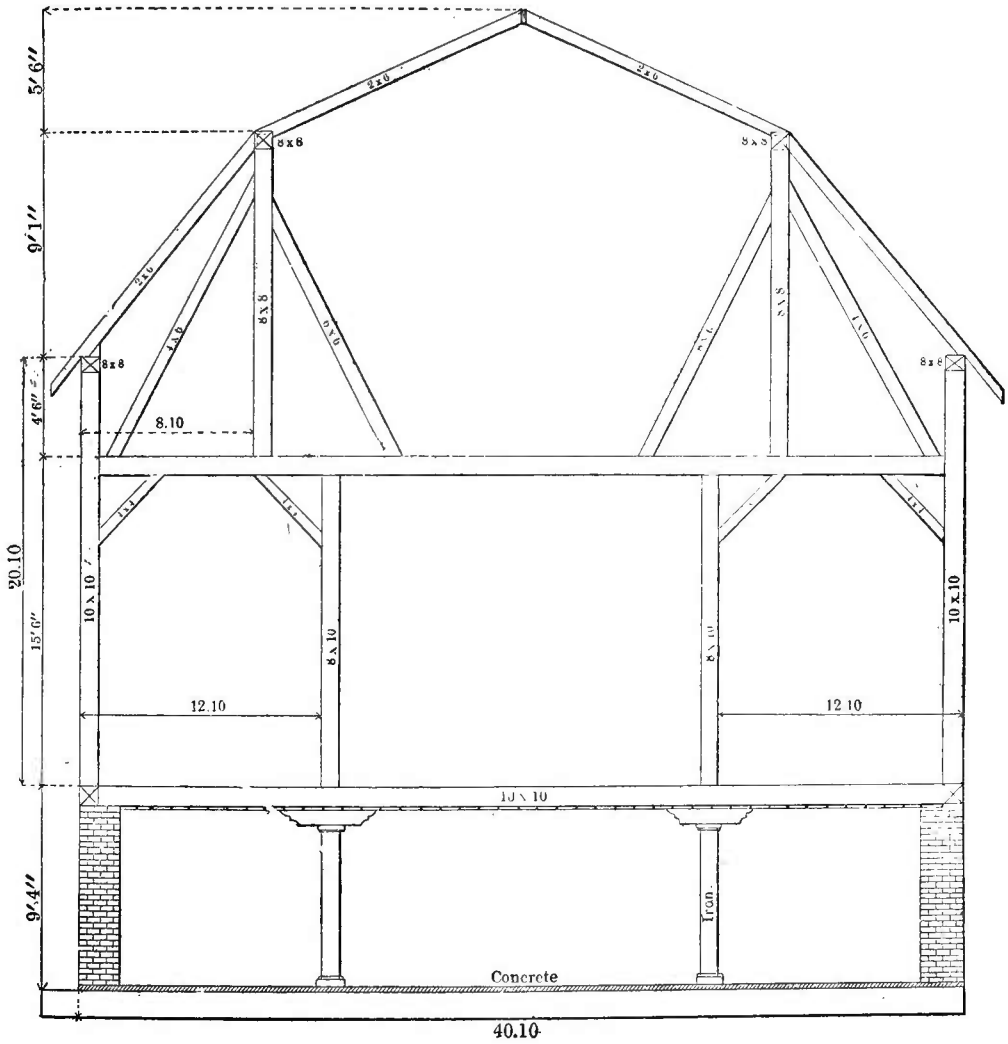

SECTION THROUGH R. S. STEVENS' BARN.

car running their entire length, spring water in all buildings with a natural pressure of seventy-five pounds to the square inch.

The silo walls are of stone-work, 2 ft. thick and 16 ft. high, surmounted by a wooden building, the posts of which are 6 ft., making the pits 22 ft. deep. They are 10 ft. wide and 40 ft. long inside, opening at the end into the stable. The inside is finished with Portland cement and is water-tight.

The main barn accommodates sixty-eight head and the second one fifty-eight head, or 126 head in the two barns. In addition to the above there are thirty box-stalls 10x14, arranged so as to open into barnyards which are graded and graveled.

The addition or "L," showing in front of the main barn, contains office, shop, store-room, and sleeping-rooms.

The building is heated by a Triumph boiler (hot water pipes), which also heats water conducted through pipes to troughs in the barnyards in winter. The other buildings shown are barn for machinery and tools, storehouse for lime, salt, plaster, etc., wagon-shed and hen-house.

The dairy-house is a two-story building 24x48, the lower story being of brick and the upper one of wood. The lower story is finished throughout with Portland cement and painted. The floors are of cement and each one drains to the center. Connected with the dairy-house is a cold-storage and ice-house 24x40. The lower story is divided into four rooms. At one end are the receiving-room 6x12 and the engine-room 12x18; next is the main working-room 24x24, containing separator, churn, power-worker, vats, etc., and last is the packing-room 12x24. The upper story is divided into shop, storeroom, sleeping rooms, and hall. The whole building is heated by steam.

HORSE BARN S.

Much of what has been said on the preceding pages of this volume concerning general farm barns and cattle barns will apply with equal force to barns particularly designed for horses; and especially is this true with reference to dryness of location, thoroughness of ventilation, and abundance of light. The horse, more than any other of our domesticated animals, is, in a state of nature, a creature of almost restless action. When not sleeping or feeding he is actively galloping and coursing over the grassy plains, drinking in with his eager nostrils the pure air of heaven which expands his lungs and sends his blood coursing through his veins with all the vigor born of health and restless energy. How important, then, when this noble animal is enslaved and made the servant of man that the conditions under which his servitude must be endured should conform in the greatest possible degree, with those upon which his native health and vigor depend. If he must perforce be deprived of his freedom to race and romp and play at will in the open air of a genial climate, let him at least be supplied with an abundance of pure air, reasonable opportunity for exercise, protection from the rigors of a cold climate which is so foreign to his nature, and in the name of humanity let him have plenty of light. A whole volume might be written upon the bad effects of illy-ventilated and badly-lighted stables for horses. It is no unusual thing among our more expensively constructed horse barns to find them so close and dark in winter for the purpose of excluding the cold and in summer to exclude flies, that the effluvia arising from the liquid excrement almost takes away the breath of one entering from the open air. Brood mares are confined in these fetid dungeons and the owner wonders and bewails his bad luck when abortion becomes epidemic among them! Stallions

and race horses are confined in these stifling equine prison pens, and surprise is expressed at the resultant blindness, pneumonia, and general debility! Why not make use of a little common sense in such matters? If the writer hereof had the whole horse-breeding fraternity of Great Britain and America for an audience he would preach them a sermon from the text: "And God said let there be light." Any system of stabling or any style of architecture in stables for horses which ignores the needs of the horse for an abundance of light and pure air is faulty; and the owner of horses so housed will most surely suffer a penalty for his cruelty, carelessness, or ignorance. Light may be admitted in abundance by means of glass windows, without any sacrifice of warmth in winter, and flies may be cheaply and easily excluded in summer by means of wire screens at doors or windows, without resorting to stifling darkness. Wire screen doors with self-closing springs are so cheaply and easily made and wire netting may be so cheaply obtained and so easily tacked over the windows and other openings that it is a matter of surprise that it is so seldom used where any intelligent regard whatever is had for the health, comfort, and thrift of the animals confined.

The light should always be admitted from the rear of the horses or from above them rather than in front or at one side; and the means of ventilation should be such that draughts will not strike directly upon the horses.

No horse-breeder can afford to ignore the fact that an abundance of light, pure fresh air and exercise are absolutely essential to the healthy development of the young horse, and this leads up to the suggestion that every man who breeds or rears horses should make convenient provision in his stable economy so that every animal may have the run of a good-sized paddock in the open air every day when not being worked or otherwise exercised. Several of the plans which follow in this volume, it will be noticed, pay ample attention to this in the arrangement of stalls, yards, etc., but whatever plan may be selected this feature should never be lost sight of.

As to internal construction it may be stated in a general

way that the linings of all box-stalls and partitions of other stalls should be made as smooth as possible, with no projecting nail heads, knots or splinters to catch and pull out the hairs of the mane or tail, and no projection under or against which the horse may rub off his mane. The top part of the manger should always be of hard, well-seasoned wood, so that the horse will not be tempted to bite it, and if the entire manger and feed-box is so constructed (as may easily be done) that there will be no part of it that the horse can grasp with his teeth the habit of "crib-biting" will never be formed and in its incipiency may be cured. Iron feed boxes and iron for tops of mangers are often used and liked by many, but others dislike them, especially in very cold climates. A room in which the harness may be neatly hung up and kept clean and in good order is an indispensable adjunct to a well-ordered stable and smoking should always be strictly prohibited.

Many valuable suggestions will be found in connection with the plans presented and the most elaborate among them may perhaps be studied with profit by one contemplating the construction of a very cheap building.

M. W. DUNHAM'S BARNES.

We present herewith a view, with diagrams, showing ground plan of a portion of the barns of the well-known Percheron and Coach horse breeder, M. W. Dunham of Wayne, Ill. Our view and plan includes only about one-half of the establishment, but the portion given shows the general plan and method of construction of the whole. These stables, with their connecting yards, are regarded by many as among the most complete of their kind that have been built anywhere, and they may well serve as a model for other breeders to pattern after. There are few who will need so elaborate a series of buildings as this, but one beauty of the plan is that it can be adapted to the wants of anyone, whether he keep ten horses or five hundred. From the detailed description and the diagrams given any good mechanic can construct a

stable after this plan adapted to the necessities of any given case; and with slight modifications it may be adapted to any variety of live stock.

Barn No. 1 is 160 ft. long by 52 ft. wide, with an awning adjustable 10 ft. wide, to raise and lower. The foundation is of stone, laid below frost; bottom of wall 16 in., top one foot in thickness. The wall is laid on east, north and west sides, and one wall of same dimensions is laid 16 ft. from north wall and parallel to it. Cross walls 10 in. thick support the partitions of the box-stalls. The south outside foundation consists of piers, 20 ft. apart, 4 ft. square on bottom and 20 in. square on top, with cap of cut stone 20 in. square on bottom and 12 in. square on top to receive the post. Sixteen feet north and parallel to this line of piers is another line built in same manner. The building is constructed (as will be seen by position of wall) with four rows of posts, the two central rows standing 16 ft. from outside and 20 ft. from each other, both ways, extending to the purline plate and supports the same. The outside posts are 20 ft. long and on north side are 16 ft. apart. All the posts are 8x8 in. and are connected by beams 8x10 in. and 10 ft. from the bottom, upon which are laid 2x12 in. joists. The two center lines of beams running lengthwise of building are additionally supported by a cast-iron angle bolted on the post under the end of each beam and running down the post and out on under side of the beam 12 in. The beams are also trussed on the top, making a solid and safe support for the joists, which run crosswise of the building. The roof is one-third pitch and formed with gables and dormers and surmounted by a cupola as shown in elevation. The outside is girted with 6x6 and four feet apart and boarded with matched and dressed lumber. The positions of windows can be seen in elevation. In second story there are four doors on the north side, with transoms, and on south side eight of same kind. In each end, as high as can be made in the gable, is a door twelve feet high and ten feet wide, through which the building is filled with hay.

From each door to the center is erected a hay-carrier, as near the ridge as possible. The building is supported by the usual cross-beams and braces. The roof is covered with the

very best dry pine shingles, boiled in West Virginia oil. (A vat of sheet-iron, 20 in. deep, $2\frac{1}{2}$ ft. wide and from 2 to 4 ft. long, according to extent of the job. Set the bunches in and have oil enough to come up to the band; let boil five minutes, take out, place on an incline with tight bottom, and drip back to the vat; in half an hour the other end of bunch can be dipped and returned on incline. In one hour they will be dry.) The cost is less than \$1 per M, and when prepared in this way they will, with an occasional coating of oil, last indefinitely, as the water will not penetrate them in the least.

The squares indicated in plans are box-stalls, 16x16 ft. square, with one door, double thick, 4 ft. 6 in. wide and 8 ft. high. Latch, a straight piece of $\frac{3}{4}$ x $\frac{1}{2}$ -in. iron, 1 ft. long, mortised into center edge of door, end protruding 1 in. to catch latch hook. An iron plate, with slot for latch to play in, is screwed on the edge and an inch hole is bored under latch to raise with. There is a window, twelve lights, 12x16, on outside, and one nine-light window, from stall to alley, for each stall, covered with No. 9 wire screening. The outside window is grated with inch refuse gas pipe, set three inches apart (cost about \$30 per ton). Windows hang on weights. The north and south sides of the stalls are sealed with 2-in. matched plank 5 ft. high, and from there to top with 1-in. matched stuff.

The partitions between the stalls are made by setting 2x4-in. studding flatwise, 6 in. apart on sill and extending 5 ft. high; both sides are then sealed with common matched and dressed flooring even with top of studding, and an oak cap 2x6 in. spiked on top. The top of this cap has $1\frac{1}{2}$ -in. holes, 4 in. from center to center and 1 in. deep, in which inch gas pipes 3 ft. long are inserted and capped with another oak cap firmly set at both ends. The floors are made of clay and gravel; an alley 6 ft. wide runs the entire length of barn, with manger on opposite side from stalls.

The hay chute is built in the outside corner, with 2-ft. run and extends 6 ft. above the upper floor, and has a slide door on long side that can be raised, leaving an opening in chute on a level with floor, when desired. The bottom of chute is grated with gas pipe 3 ft. 6 in. long, set on incline

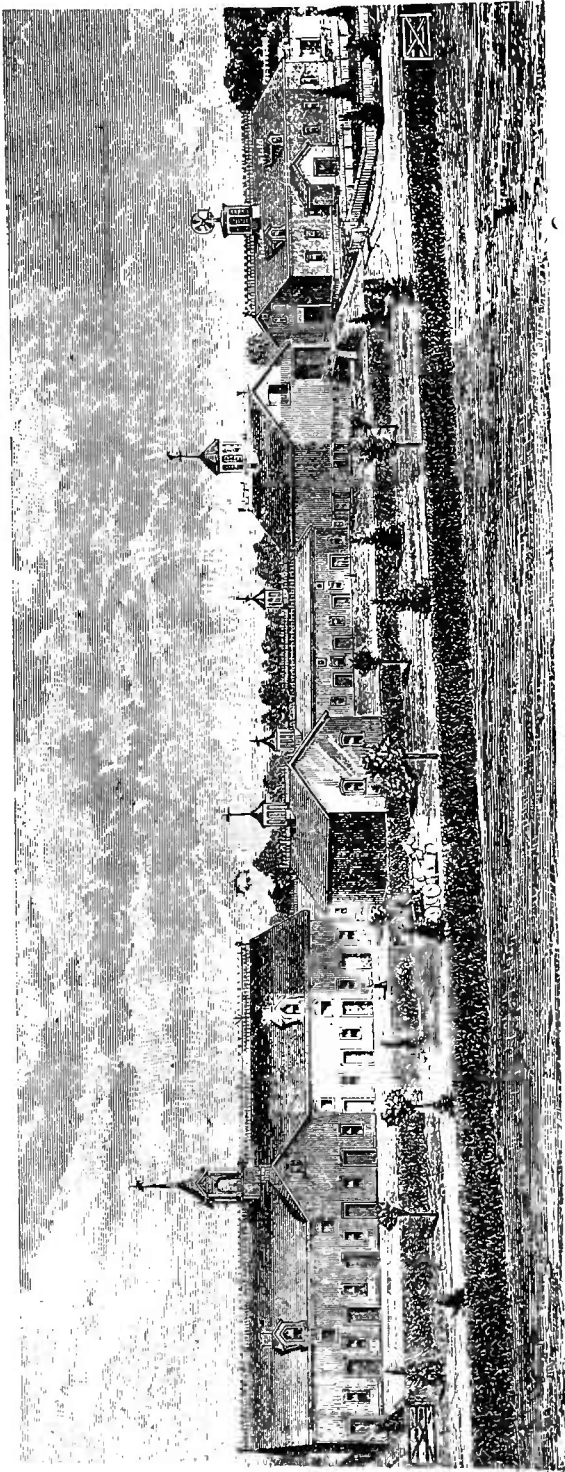

VIEW OF M. W. DUNHAM'S BARN.

from corner to outside of bottom of chute, which is 6 ft. from floor to stall. These pipes are set 6 in. from centers at top and one of them moves in a slot, so as to double the distance when required.

Under the chute is a manger made of oak, with a side run of 3 ft. 6 in.; its height is 3 ft. 6 in. and sealed in front to bottom of stall. In opposite corner is the grain feed box opening into alley by slide door 1 ft. 8 in. by 2 ft. 6 in., hung on weights. Feed box is made same as manger, only smaller.

The large space with posts in center is divided by movable plank partitions 5 ft. high, the end bars of which run as high as the beam and are hung to same with a hinge. These partitions can all be raised to the ceiling and are held there by four wooden hooks with the lower parts beveled. When the partition (or door) is raised the hook is thrown back until the door enters the notch (or hook), which falls over it and holds it. By this means the whole south portion of the building can be thrown into one great shed or divided into small stalls, and when the awning is down everything is perfectly protected. The yard fences are also made movable by sockets tamped into the ground to receive the posts, which are tapered and can be taken out with perfect ease and the hole plugged. The bins for feed are made in second story and are located directly over the hydrant, at which point a box is located for mixing feed.

Barn No. 2 consists entirely of box-stalls, made on same plan as those described above and open into yards to the south. It is 16 ft. high at eaves, with loft for fodder.

Barn No. 3 is 40x80 ft., 26-ft. posts, with 96-ft. extension to the south. All boxes are same as described. The single stalls are 5 ft. wide and made on the usual plan, with plank floors, hay being fed in chutes from above. The upper part is reached by an embankment and bridge. A hay-carrier is also rigged in it, door opening to the north. Large feed-bins are located over north end of the alley, where water is marked in diagram and a mixing-box filled from spouts from bins is placed beside the hydrant.

No. 4 is an open shed facing south, with yard in front.

No. 5 is 50x100 ft., with stone basement, the walls 26 in. on

bottom and 16 in. on top. The building rests entirely on the outside wall. The sills are 8x10 in., the posts 20 ft. long and about 14 ft. apart. The girths are 6x6 in. and 4 ft. apart. The roof is a truss roof of the strongest kind. (See elevation for location of windows, cupola, etc.) The boarding is of the best dressed and matched flooring. On north side and center is a cutting-room, 20x24 ft., cutter standing on a level with second floor (see elevation). The basement is divided by three 6-ft. alleys, running north and south, connected by one 4-ft alley running east and west along the north side. On each side of each alley are four box-stalls about 12x14 ft., with plank partitions 5 ft. high and doors opening from one to the other to the outside. Hay comes from third story through chutes opening in the alley and is fed in mangers. The second floor is divided entirely into single stalls, as will be seen on plans, with an alley in front of each row for feeding grain and watering. Hay comes from above in chutes, as in other stalls. The floors are 2-in. matched plank, tarred and then covered with paper, two thicknesses. On top of this is laid 3-in. plank, boiled in oil and keyed together every five feet. Between the two floors is an iron gutter, just at the back end of the stalls, with iron outlets running down the basement into the drains. The stalls are 5½ ft. in the clear and the partitions are 3-in. plank, doweled together 4½ ft. high, and the front rises in an oval shape and is barred. The stall posts are 6x6, oak; 3x12-in. joists run from stall posts to outside building and 2-in. matched plank is used for floor above, so that the space over the horses' heads is perfectly smooth. The ceiling over the floor back of the horses is 12 ft. high and 20 ft. wide, with a 14-ft. slide door at each end. Over each stall is a finished panel set with pictures of Percheron horses. The stalls and ceiling are painted in nicely contrasting colors. The entire water system is supplied from a 2,000-barrel reservoir or cistern (constructed on a hill sixty feet higher than the barns and 100 rods away) built of stone laid in cement and completely covered from the frost. The water is forced into this reservoir by wind power, and is drawn by a 2½-in. main

to the buildings and distributed through them by 1½-in. and 1-in. pipes laid 5 ft. under ground.

The wagon house has a self-supporting roof and the entire front is composed of sliding doors. Carriage houses and straw sheds are ordinary frames. All yards are graded and graveled in such manner that they are perfectly free from mud at all times of the year.

The arrangement of the yards can be seen from the diagram. All the manure, except from barn No. 1, goes to the elevated track indicated and in winter time is dumped into wagons and hauled out. The total length of front shown in the diagram is 600 ft.

M. W. DUNHAM'S COLT STABLES.

Mr. Dunham has quite recently added to his establishment a series of stables, located in his several pastures, as shown in diagram herewith presented, which he regards as

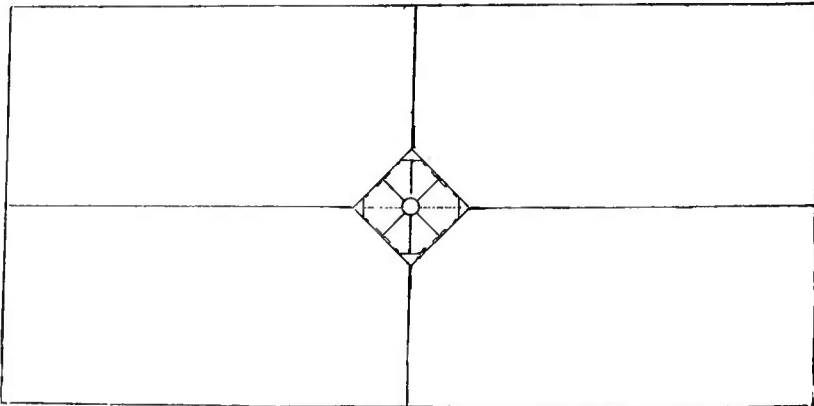

of especial value with reference to the development of young horses. He describes these stables as follows:

They are situated in line east and west, about forty rods from building to building. The strip of land used is sixty rods wide. This gives a pasture 20x30 rods for each field and each affording abundant pasture for two animals the year round. Of course in the winter a certain amount of hay is necessary. Each stable contains stall room for eight animals, with the partitions in (see page 124), so

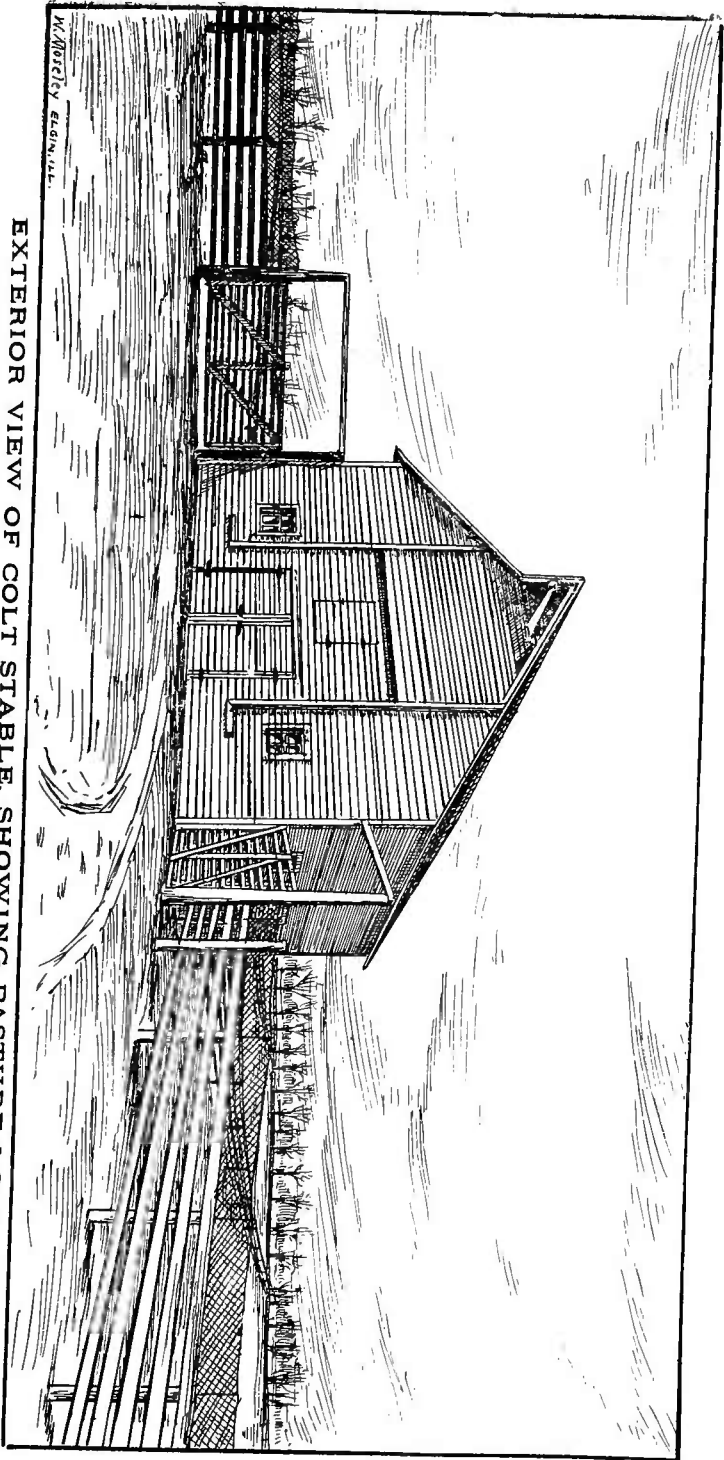

W. MORSEY ARCHT. ILL.

EXTERIOR VIEW OF COLT STABLE, SHOWING PASTURE LOTS.

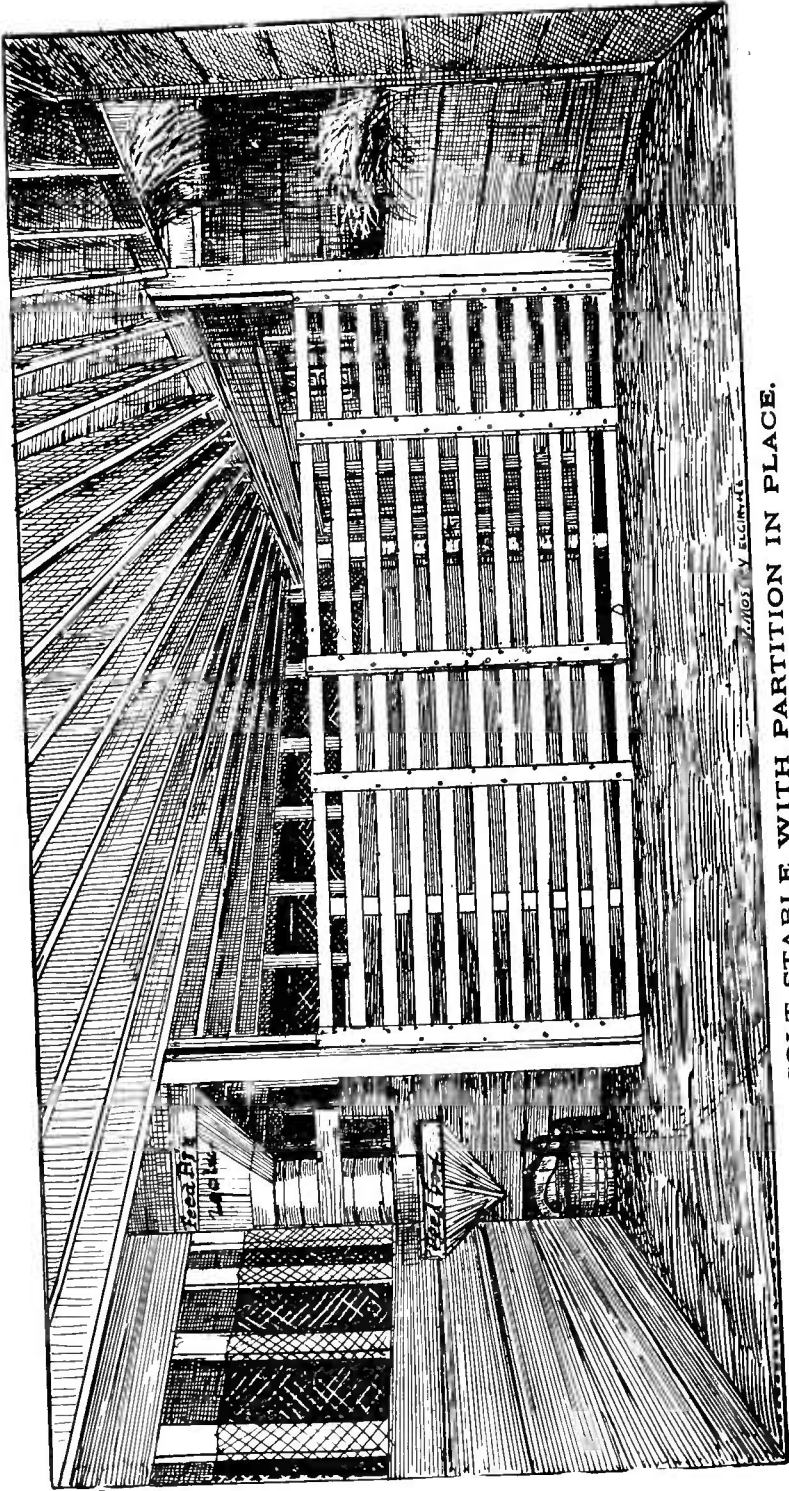

ARCHITECT Y. ELLIOTT

COLT STABLE WITH PARTITION IN PLACE.

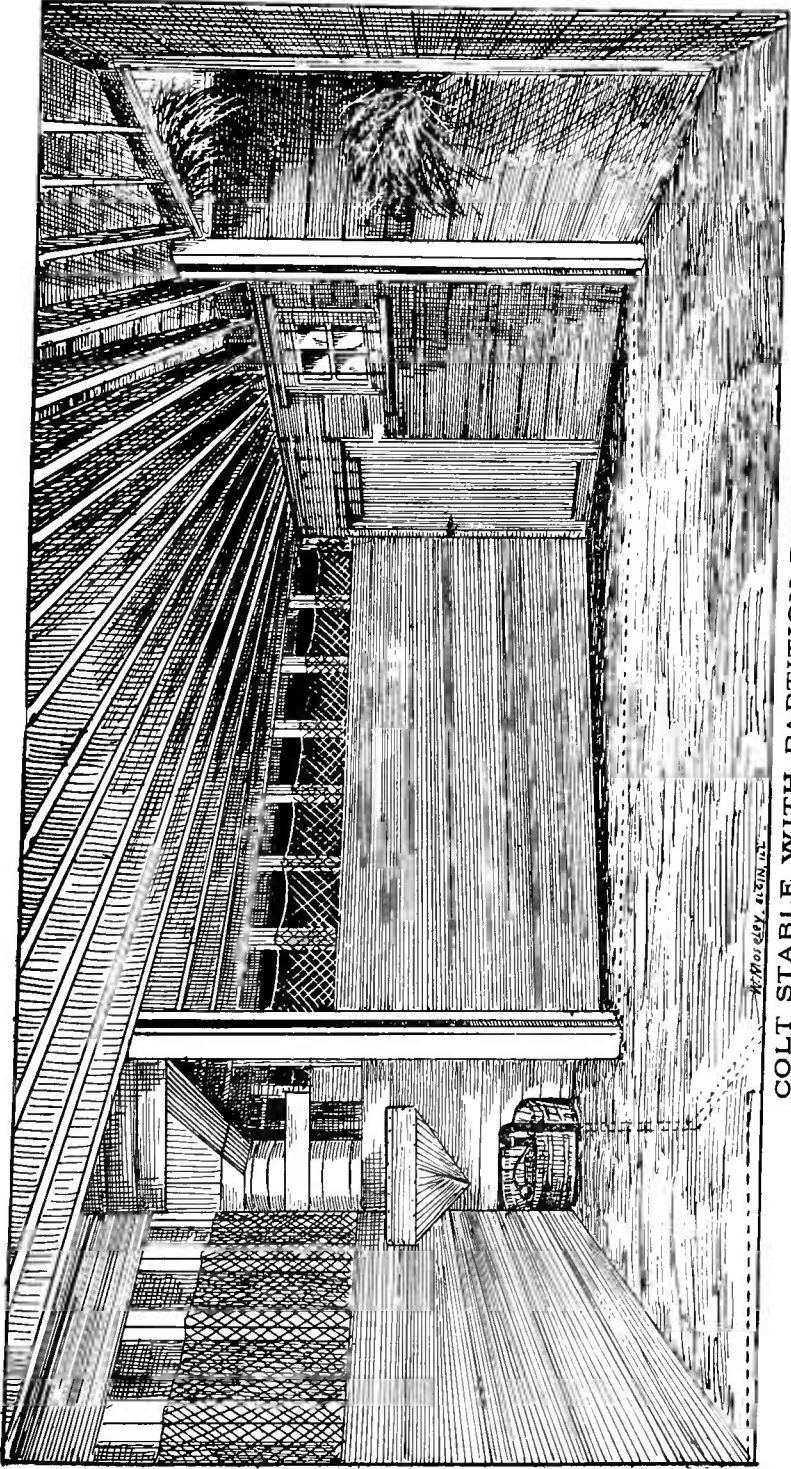

COLT STABLE WITH PARTITION REMOVED.

that four animals are in the fields and four in the stable alternately. In the summer time the doors are left open and are provided with a canvas fastened at the top, fitting the doorway closely. This excludes the light and protects the animals when in the stable from the flies. In the angle of each stall, which combine to form the centre of the stable, is a hydrant to which is attached a float valve which controls the supply of water, except in the intense cold weather in the winter, when the float valve is removed and the tub filled with water from the hydrant as required.

The grain is also fed from the centre, directly over the water tub. The feed bin is about six feet square and of sufficient height to hold about two hundred bushels of oats. The bottom of the bin tapers to the centre at an angle of about sixty degrees and is closed by a circle of sheet-iron with eight holes of sufficient diameter to hold two quarts of oats, and projects to within two inches of the bottom of the feed trough. Another sheet-iron plate, fastened in the centre, with holes corresponding to the pipes, is placed flat upon its top surface to which is riveted a lever. The slot in which this lever works is long enough to allow the opening and closing of the holes in the lower plate by the movement of the lever. By this device the movement of the lever permits the filling of the pipes with oats and the reversal shuts off the supply, giving each animal two quarts, or any quantity the pipes are made to hold—the grain filling the pipes—and is eaten from the bottom. This method of feeding has the advantage of rapidity, uniform quantity, prevents waste and secures slow feeding, consequently better mastication. The fences enclosing the pastures are seven feet high, the upper two feet being made of woven wire.

The necessity for natural development of young horses in the open air and on green feed in order to secure the highest usefulness when grown has led me for many years to pasture my young stallions in the summer; and the losses incurred by accident where numbers were kept together prompted the devising of the plan just described. The pro rata expense of providing a building for eight animals, including fence for the pastures, is about \$125 per head.

I have found that the use of these buildings and pastures is of great advantage. Where the animals are put in in a healthy condition there is almost entire immunity from disease. By this means health and natural growth are secured and accidents and unsoundness are rare. During the past year my man in charge of the stock kept in this way tells me that he has not given a single dose of medicine to the colts that have been so stabled.

Mr. Dunham's idea is fully illustrated in the engravings herewith submitted.

W M. FIELDS & BRO.'S BARN.

The illustration herewith given is that of one of the barns of Messrs. W. M. Fields & Bro., Cedar Falls, Ia., which architecturally is regarded as one of the finest structures of the kind in the State. Only the main-floor plan is given. The basement plan should be nearly identical with it if devoted entirely to box-stalls for horses, or it might be—as the Messrs. Fields have heretofore used it—cut up into stalls for cattle and horses. The hay chutes will in any case bring the hay from the loft, and at the same time afford excellent ventilation.

Size of building, 40x100 ft. Walls of stone 2½ ft. up to main floor and 2 ft. thick above that. Gable walls 18 in. thick. Interior frame of 8x8 stuff, with posts extending to and supporting the roof. Joists 2x8 and 18 in. apart. Floors of 2-in. plank. Floor of loft 8-in. shiplap. The loft extends over all except the intersection of the two hallways. Grain and feed bins in the loft above stairways. Roof about four-tenths pitch. Eaves and gables project 2½ ft. Sides of stalls and hallways of matched shiplap. Partitions are solid 6 ft. high, with grating of 2x4 scantling above that to joist above. The water is pumped into a tank by windmill; the overflow should run into the basement tank.

Expense items follow: 1,318 small perch stone walls and foundation 3 ft. wide and 5 ft. deep, at \$1.75, \$2,306.50; 28,000 stuff lumber, at \$19, \$532; 10,000 shiplap, at \$27, \$270; 55

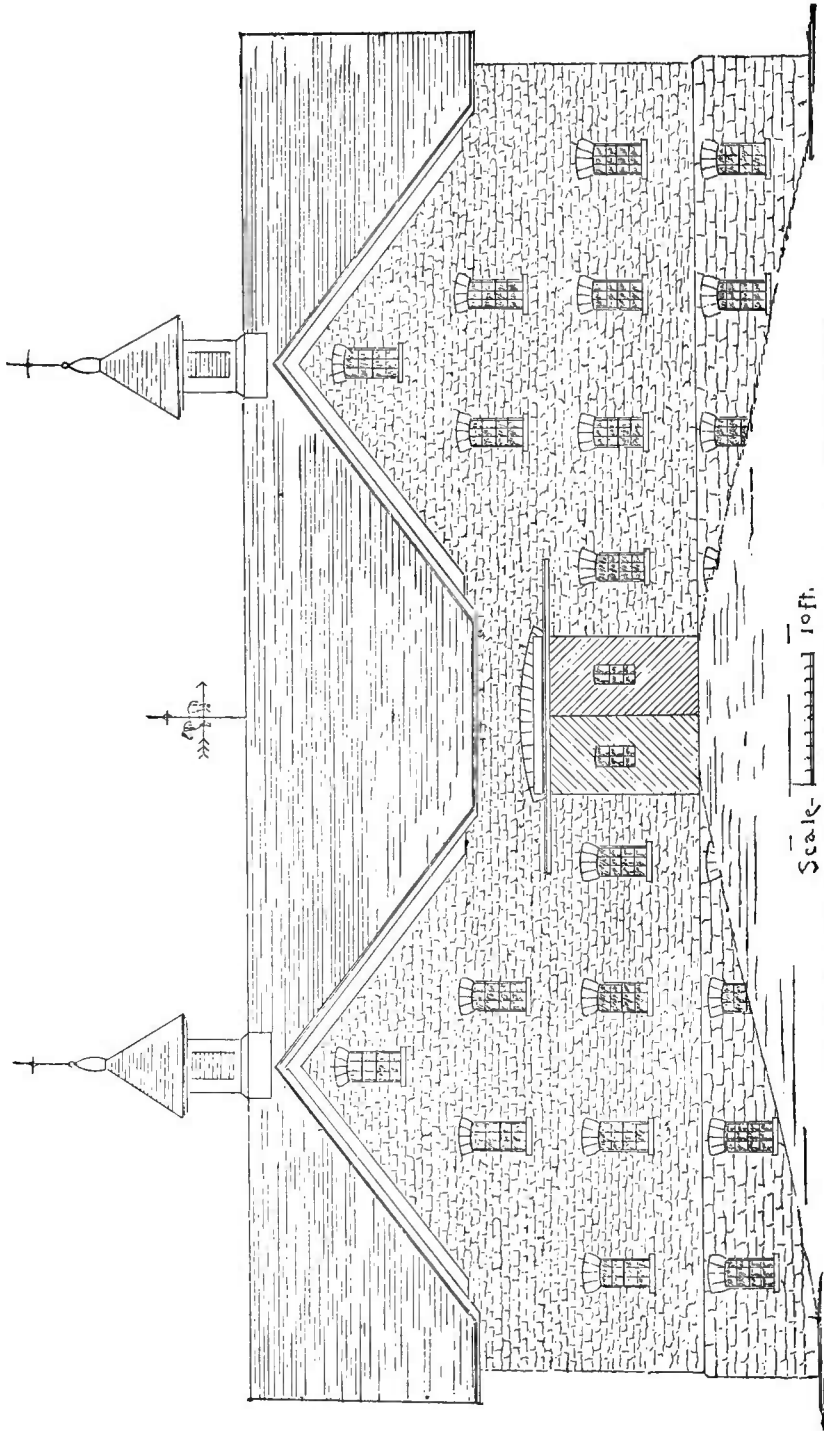

Scale 10 ft.
W. M. FIELDS & BRO'S HORSE BARN—ELEVATION.

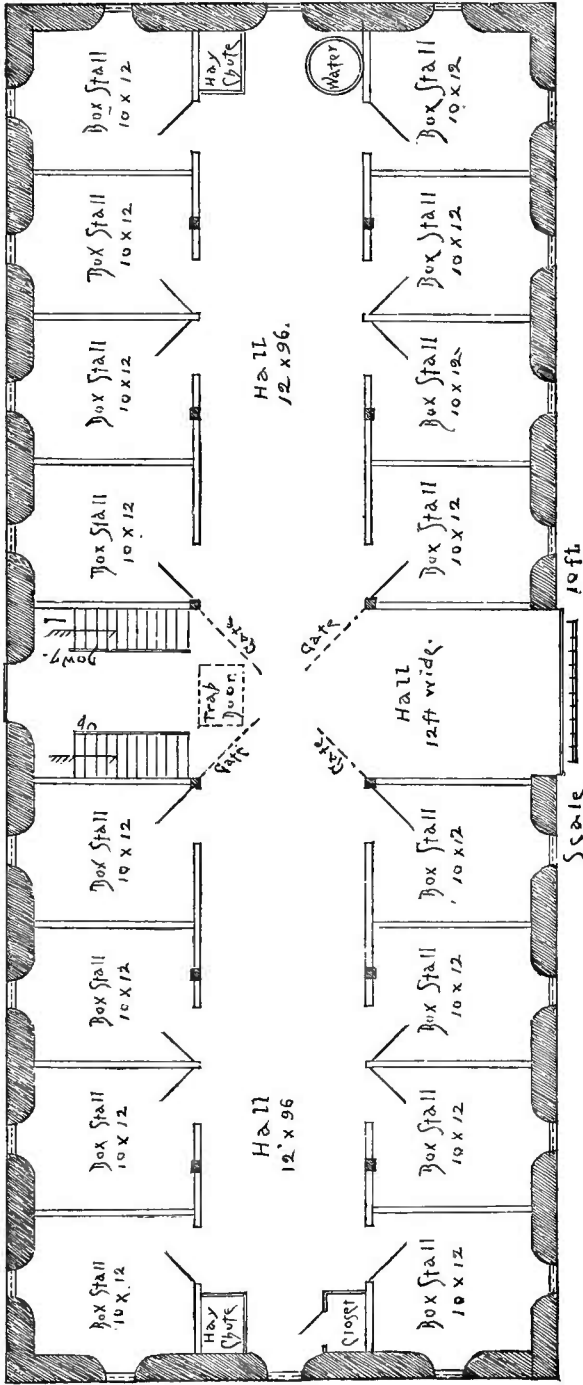

Scale 10 ft
MAIN FLOOR OF W. M. FIELDS & BRO.'S BARN.

M shingles, at \$4.50, \$247.50; 7,000 sheeting, at \$16, \$112; carpenters, 57½ days at \$7, \$400; hardware, glass, paint, piping, etc., say \$300. Total, \$4,168.

This does not include the expense of fitting up the basement, which would vary probably from \$350 to \$500 additional, according to the plan adopted. The prices for lumber are about such as prevail in that section. The exact cost of the barn is not known, but the above figures approximate it.

E. STETSON & SONS' STALLION BARN.

The stallion barn built not long since by E. Stetson & Sons of Neponset, Ill., is regarded by many as a model of convenience, although there is nothing very pretentious in its architecture, neither is it an expensive building. Dr. Stetson has favored us with the following details of its construction:

Fig. 1 represents the south elevation of barn and shed connected with same. No. 2, basement with box-stalls, and No. 3, the plan of the yards and distribution of water. Nos. 4 and 5 explain themselves. The barn (40x70 ft.) is located on the south, and near the top of a gentle ridge running east and west. It is constructed partly on the side-hill, or basement plan, the north wall being only full height of basement, and this wall is all above ground except three feet, which gives room for large windows. All other foundation walls are on a level and extend but a few inches above the ground floors, which are of earth in the boxes as well as in the driveway of basement. Foundation walls and framework of basement correspond with the main framework of the building. The framework, consisting of five 14-ft. bents, gives the space of 28x40 ft. on each side of the driveway on the second floor. This driveway is reached from the north side of the building. A stone wall 20 ft. long and parallel with the building, 14 ft. distant, gives foundation for a driveway. Against this earth is graded, forming an easy approach to the second floor.

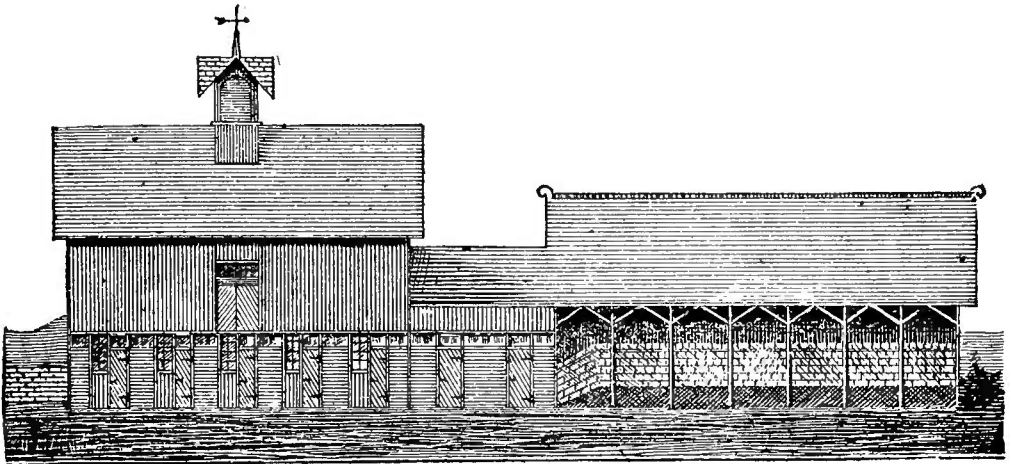

FIG. 1.—ELEVATION OF STALLION BARN.

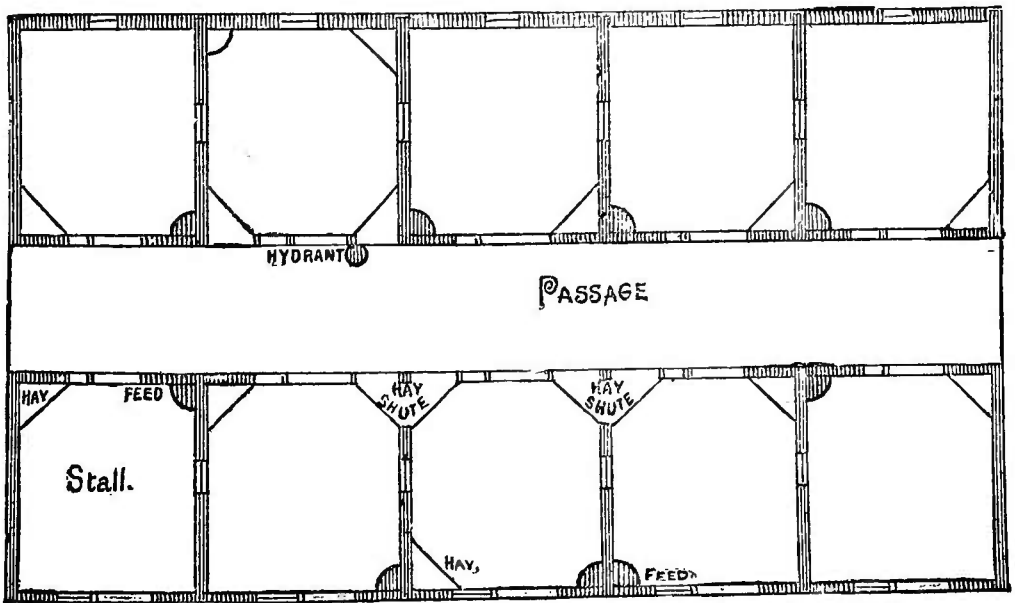

FIG. 2.—GROUND PLAN OF MAIN STALLION BARN.

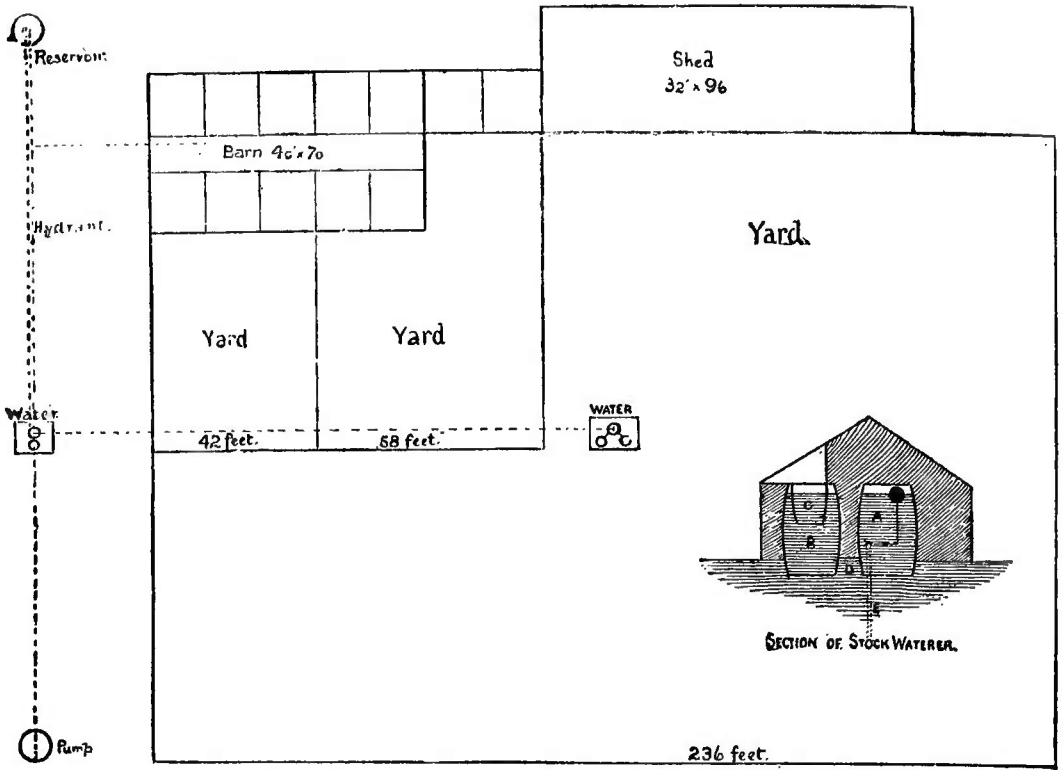

FIG. 3.—DIAGRAM OF YARDS, SHOWING WATER SYSTEM

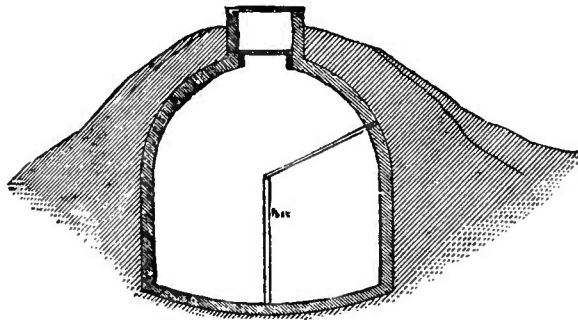

FIG. 4.—RESERVOIR.

The watering arrangements in particular have proved highly satisfactory. The reservoir, or cistern, is located on the highest ground obtainable, and this not being as high as desired a portion of the arch is built above the natural level and heavily banked with earth. It is bricked up from the bottom with an eight-inch brick wall laid in cement, and the mortar well flushed against the earth bank and finished with a heavy coating of cement on the inside of brickwork. The pipes should be laid at the same time the cistern is built. The diagram (see Fig. 4) shows the manner of constructing the arch. A post is firmly set in the center of the cistern to a height at which the arch is designed to commence. A hinged rod is attached to the top of this post, which is swung round by the workman as his work proceeds and enables him to form a perfect arch.

Inch-and-a-quarter gas pipe is laid from cistern to hydrant in barn basement, and also to yards and pastures as desired.

The diagram representing stock-waterer (included in diagram Fig. 3) shows two barrels set side by side, connected by a short piece of gas pipe *D*. The water enters the barrel *A* from the bottom *E*, to a height controlled by a float connected by a copper wire to a hinged valve. This allows the water to stand in the barrel to just such a height as desired and no higher. As the barrels *A* and *B* are filled to the same height any water taken from the drinking-tub *C* is quickly replaced. We use for a drinking-tub one-half of a beer barrel, set in the end of a kerosene barrel, which is the best use to which an empty beer cask can be put.

MILLER & SIBLEY'S BARNS.

Messrs. Miller & Sibley of Franklin, Pa., have originated a system of barns, stables, and exercising track which has frequently been spoken of in such high commendation by breeders and trainers of trotting horses that we illustrate the same herewith for the benefit of such of our readers as may wish to adopt some of the features which have been so successfully used in this establishment:

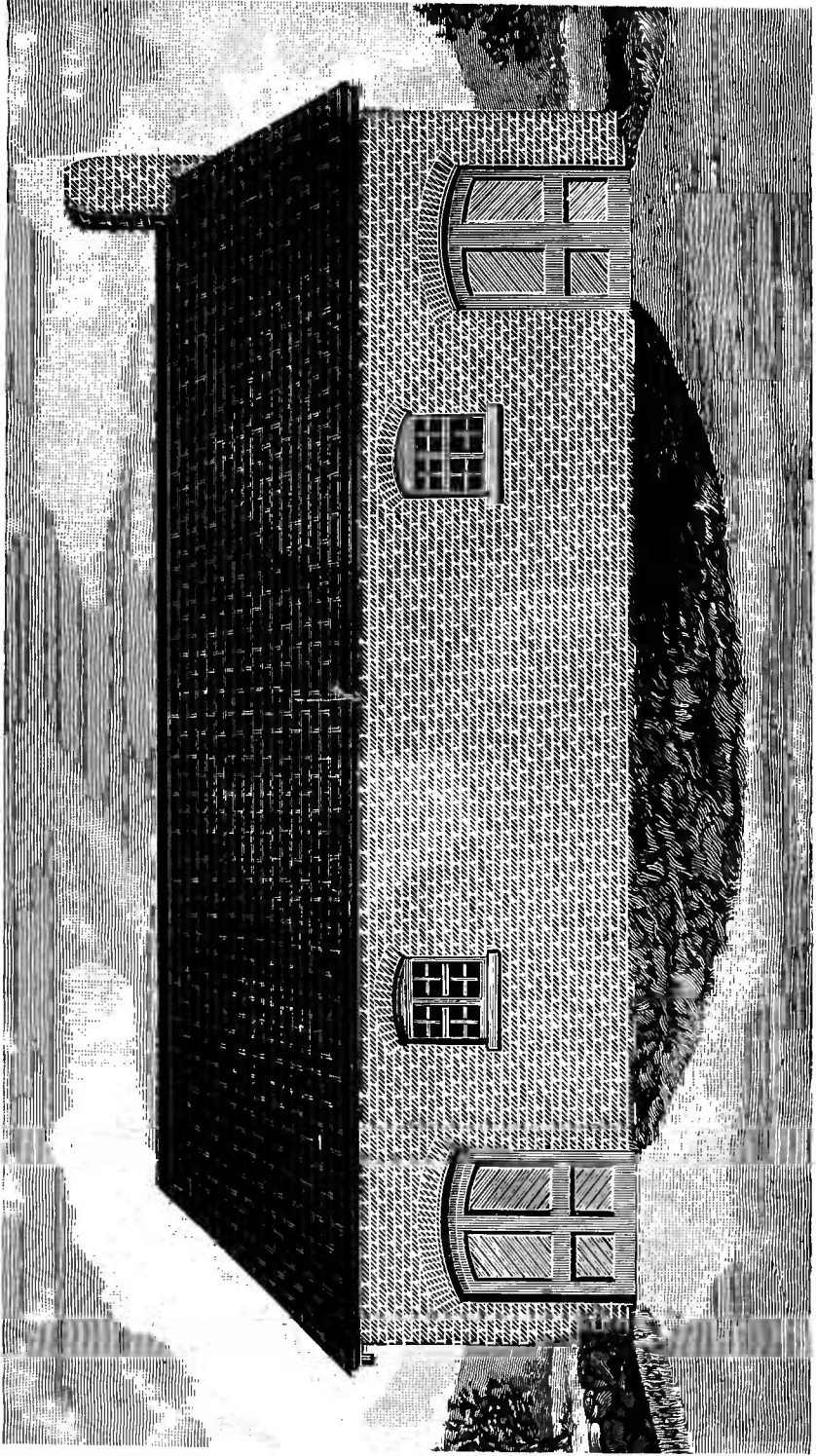

MILLER & SIBLEY'S STALLION BARN.

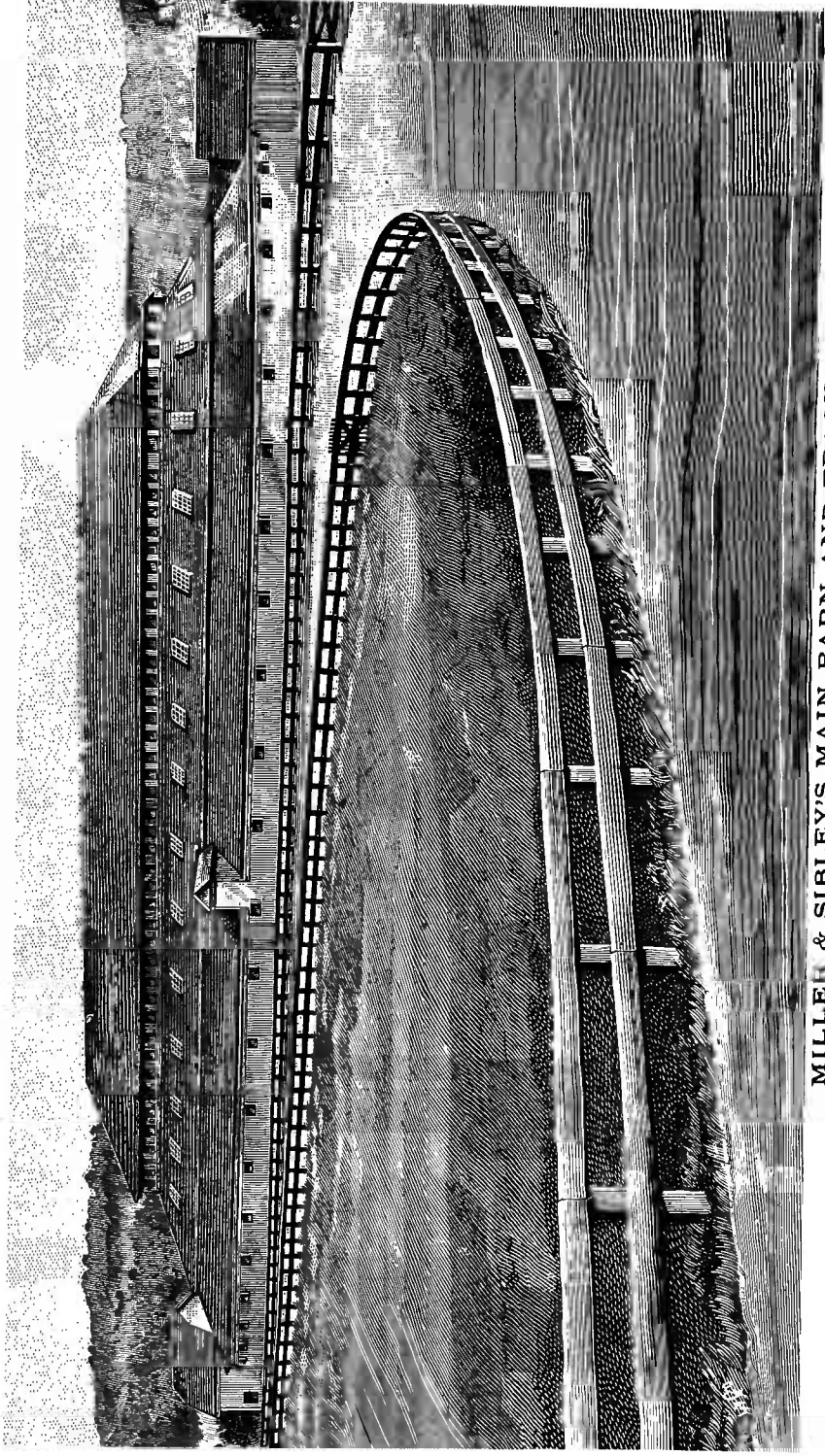

MILLER & SIBLEY'S MAIN BARN AND TRACK.

The ground plan of the main horse barn is in the form of an ellipse flattened at the poles and the whole building is under one roof. The exterior circumference is 900 ft., the extreme length 374 ft. and the extreme width 168 ft. The

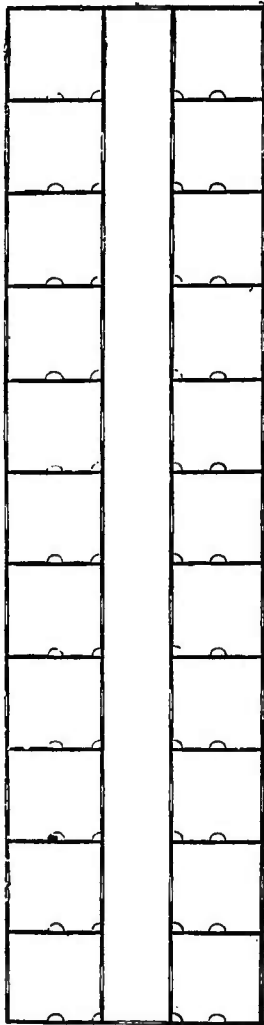

GROUND FLOOR—MILLER & SIBLEY'S TRAINING STABLE.

extreme height of the building is 56 ft. A space 10 ft. in depth, extending clear around the building, is partitioned into forty-eight box-stalls, 10x14 ft., which are warmed by steam pipes passing through them. The space over them extending to the roof is used for storing hay and straw. At either end of the barn are cooling rooms. Immediately interior to the box-stalls is a tanbark track for training purposes and for exercising brood mares. It is 14 ft. wide and one-seventh of a mile in circumference, and being entirely inclosed horses can be given steady work in an even temperature regardless of weather. Interior of this track is a circuit of sixty-eight smaller box-stalls, 10x7 ft., leaving a wide passageway at either end. Inside of this is a covered court 296 ft. long and 90 ft. wide, in the center of which is a colt-track one-thirteenth of a mile long. The building is ventilated by means of skylight windows controlled from the ground and is lighted by electric lamps.

The stallion barn is 56 ft. square, is built of brick, with slate roof, and is practically fire-proof. There are six box-stalls in this barn 11 ft. 6 in.x14 ft. 6 in., and between the stalls and the outside wall is an aisle 8 ft. wide extending clear around the barn. Flues from near the bottom of each stall lead to the furnace in the outside wall and the building is thus

thoroughly ventilated. The circular brood-mare barn is 80 ft. in diameter and contains fifteen stalls 15 ft. long and 14 ft. wide at one end and 9 ft. at the other. The space above these stalls is used for storing hay and straw.

H. C. JEWETT & CO.'S BARN.

At the Jewett Stock Farm, the property of Henry C. Jewett & Co., Jewettville, Erie Co., N. Y., may be seen a series of barns especially designed for the accommodation of a breeding stud of trotting horses, which is regarded by many as the most complete thing of the kind in the country. The engravings herewith given show the plan and mode of construction of the principal barn, which is 432 ft. long with projecting wings 48x48 ft. on each side. The material employed in its construction was as follows:

Bill of lumber, barn 432 ft. long and 48 ft. wide with wings 48x48 each side: 2,450 lin. ft. 8x8 sills; 2,450 lin. ft. 6x8 plates; 84 posts, 8x8, 20 ft. long; 88 posts, 8x8, 34 ft. long; 44 beams, 8x8, 22 ft. long; 44 beams, 6x6, 22 ft. long; 84 beams, 6x8, 12 ft. long; 640 girts, 4x4, 12 ft. long; 16 girts, 4x6, 22 ft. long; 206 girts, 4x5, 14 ft. long; 1,560 joists, 2x8, 12 ft. long; 125 brace-pieces, 4x4, 14 ft. long; 15,000 ft. (surface measure) matched pine, $\frac{3}{4}$ in. thick, hay-loft floors, etc.; 28,000 ft. (surface measure) matched pine, $\frac{3}{4}$ in. thick, ceiling the inside of the outer walls of box-stalls, etc.; 22,000 ft. (surface measure) 10 ft. long, Norway pine, 2 in. thick, box-stall partitions; 30,000 ft. 1 in. hemlock roof boards; 225 M 16 in. clear pine shingles XXX; 25,000 ft. barn boards $\frac{7}{8}$ x12, D. I. S.; 25,000 lin. ft. 1x3 cove battens; 2,200 lin. ft. cornice, 1x15. 1x12, 1x5, 4 $\frac{1}{2}$ crown molding; 5,000 ft. (surface measure) Norway, ceiling up and in tower; 4 posts, 8x8, 8 ft. long; 6 beams, 8x8, 22 ft. long; 18 joists, 2x8, 22 ft. long; 56 studs, 2x4, 14 ft. long; 4 posts, 4x4, 14 ft. long; 28 rafters, 2x5, 12 ft.; 750 ft. 1 $\frac{1}{4}$ -in. pine flooring; 88 lin. ft. cornice, 1x6, 1x8, 4 $\frac{1}{2}$ crown; 88 lin. ft. balustrade; 12 posts for balustrade, 6x6 in.x3 ft. 6 in., turned top; 10 window frames and glass sash, 12x32, 4-light, 5 $\frac{1}{2}$ jam; 2 O. S. sash doors and frames, 2 ft. 10 in.x 8 ft., 4-light, 5 $\frac{1}{2}$ jam;

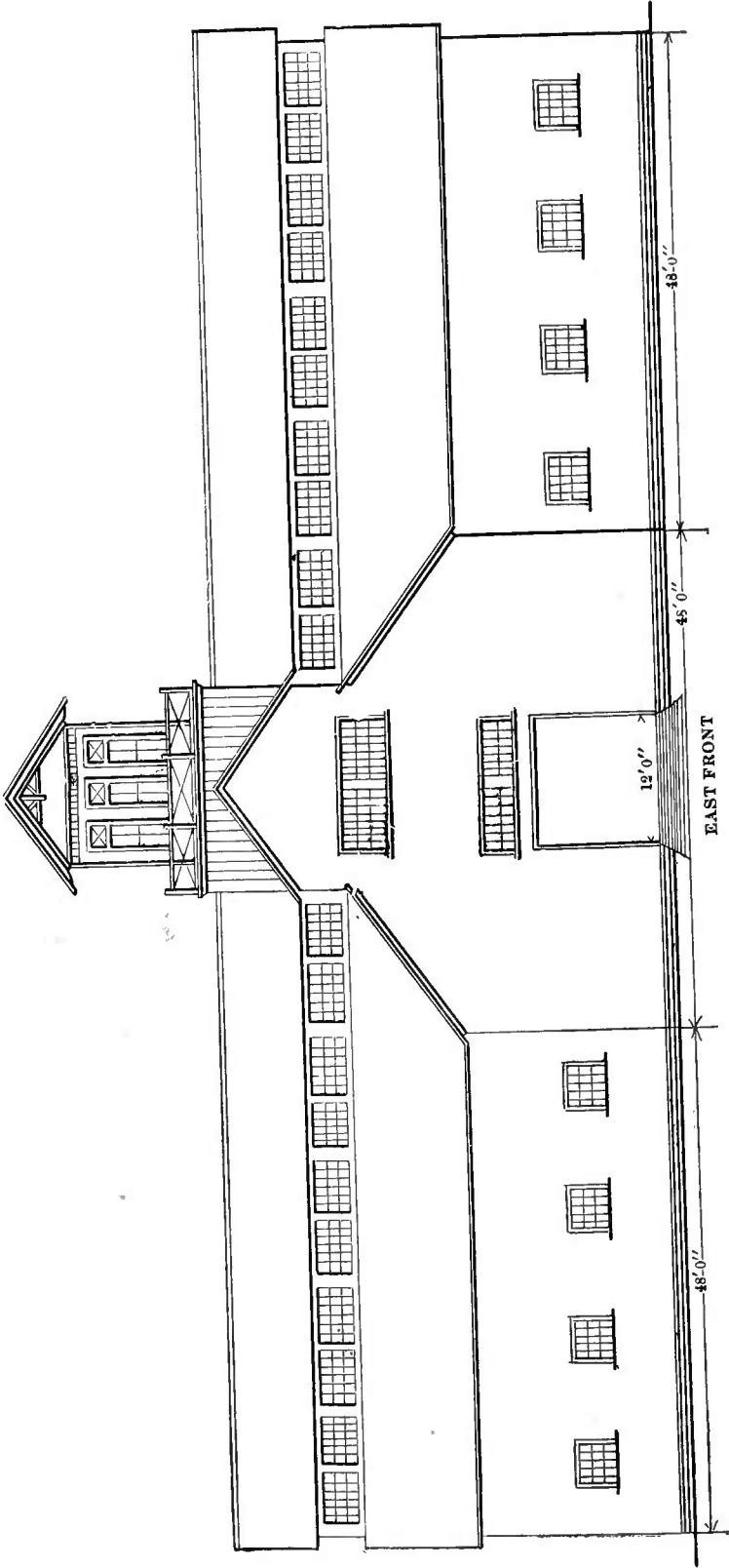

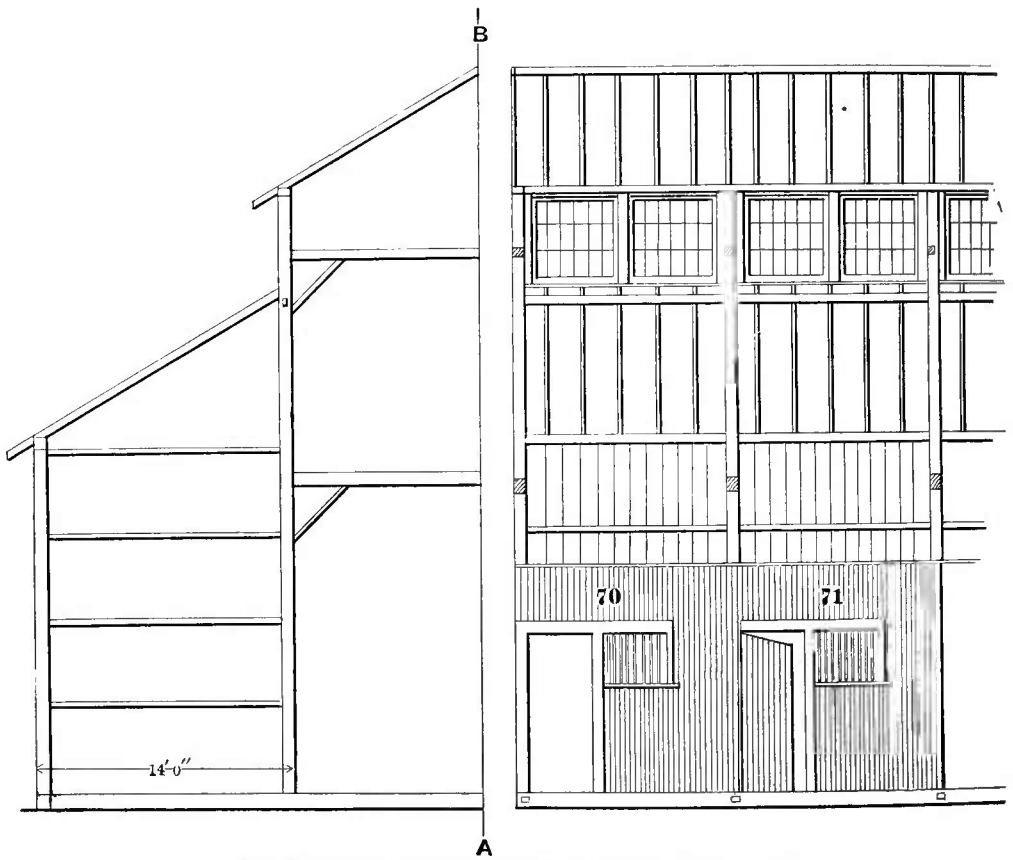

SECTION THROUGH LINE AT A. B.

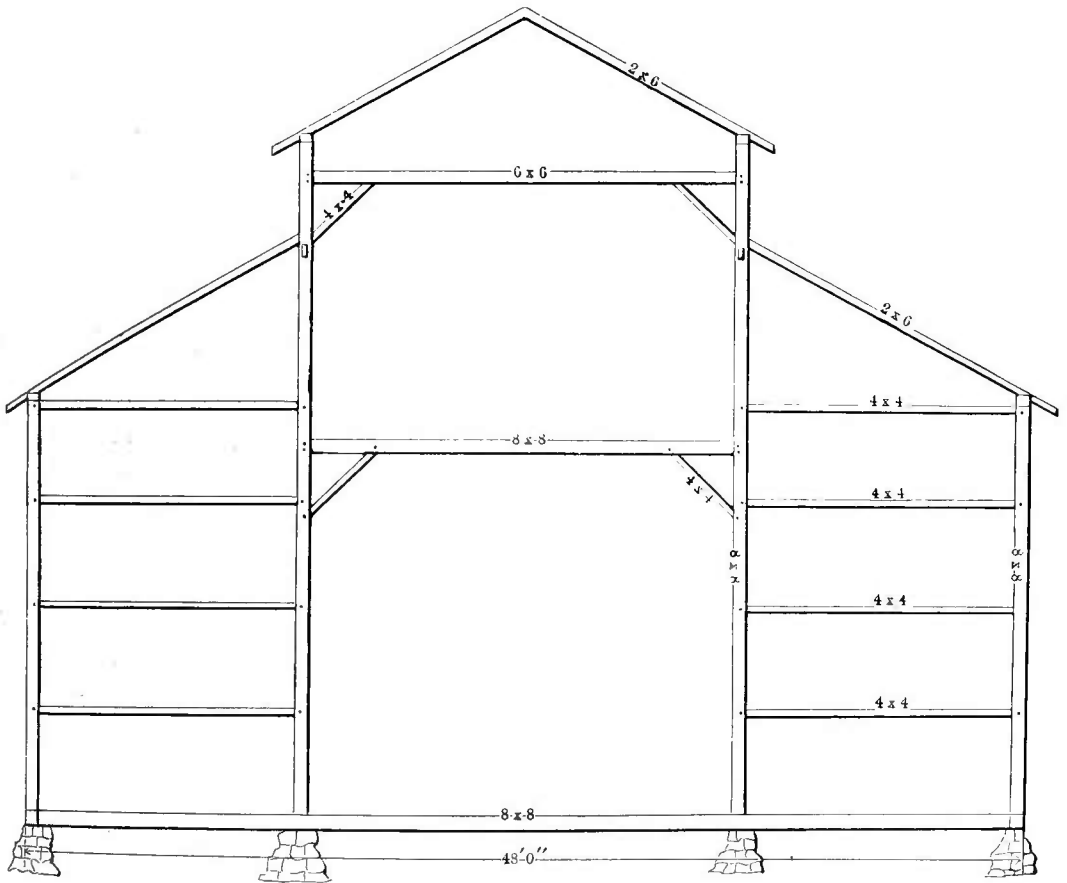

SECTION OF FRAME.

400 ft. 1x12 barn boards; 400 ft. cove battens; 4 ornamental gables; 1 large finial; 125 lin. ft. 1½x12 stair stringers; 56 rises, ¾x7¾ in., 2 ft. 10 in. long; 55 steps, 1¼x10 in., 2 ft. 10 in. long; 90 lin. ft. hand-rail, 2x3½ pine; 80 box-stall window frames and glass sash, 8x14, 18 lights; 4 mull window frames and glass sash, 8x14, 24 lights; 4 mull window frames and glass sash, 8x14, 16 lights; 88 mull window frames and glass sash, 8x14, 18 lights; 14 single window frames and glass sash, 8x14, 12 lights; 2 pair barn doors on rollers, 12x12 ft.; 2 pair barn doors on rollers, 10x10 ft.; 64 box-stall doors, 3 ft. 6 in.x8 ft.; 64 box-stall ventilator window frames, 3 ft. 6 in.x3 ft.

J. F. GOODSON'S BARN.

This very convenient, cheap, and handsome horse barn recently erected by Mr. J. F. Goodson of Carrollton, Mo., is described by him as follows:

I herewith send you a sketch of a horse barn that I have built, and would especially direct attention to the fact that the posts stand upon stone pillars without sills, and also to the long timbers without mortises or tenons. If the braces are put in properly the building stands perfectly firm and unshaken, and costs much less than the usual plan of framing.

No mortise nor tenons; gain into post and spike strong. Get lumber long enough to reach past one post and to the next. Where it is possible spike pieces, say four feet long, over the splice. Ground floor dirt; second floor matched inch boards; third floor for hay to be rough boards. No sills; posts set on heavy stone; ground raised, say one foot, or near the top of stone pillars. Posts 8x8x20 ft.; stringers 2x6x20 ft. (break joints on every post; rafters 2x4; purline posts 6x6; two 2x6 pieces spiked together, braced from bearing to center between posts. Size of stalls between posts, 10x14; total size of barn, 43x64.

This barn cost \$900. It holds sixty tons of hay. In corner over back stall on left side is a corn-crib 10x14x12. Adjacent to upper hallway or feed-room, and in the space where no feed-holes are necessary, are the bran and oat bins, with

J. F. GOODSON'S BARN—ELEVATION.

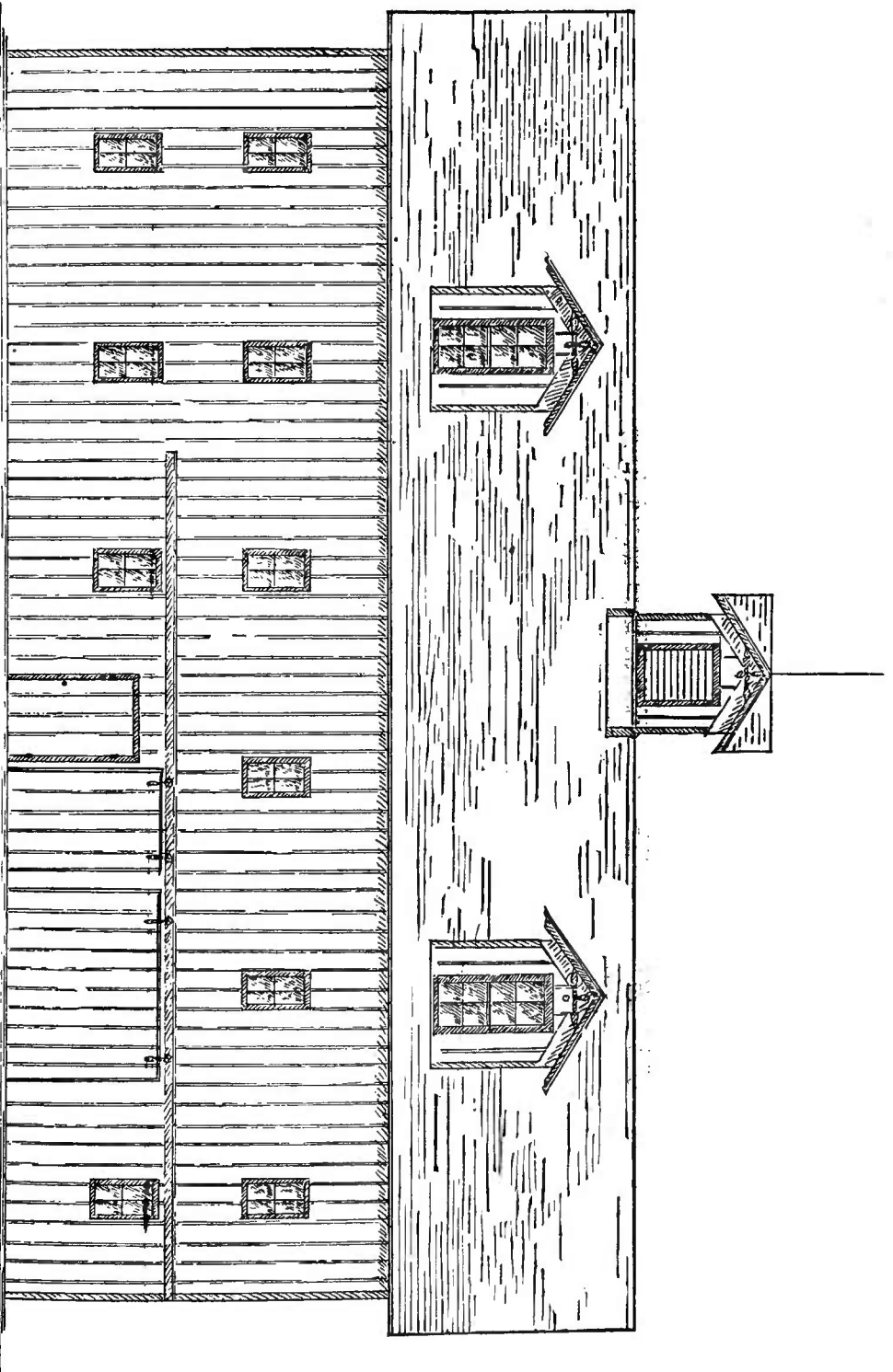

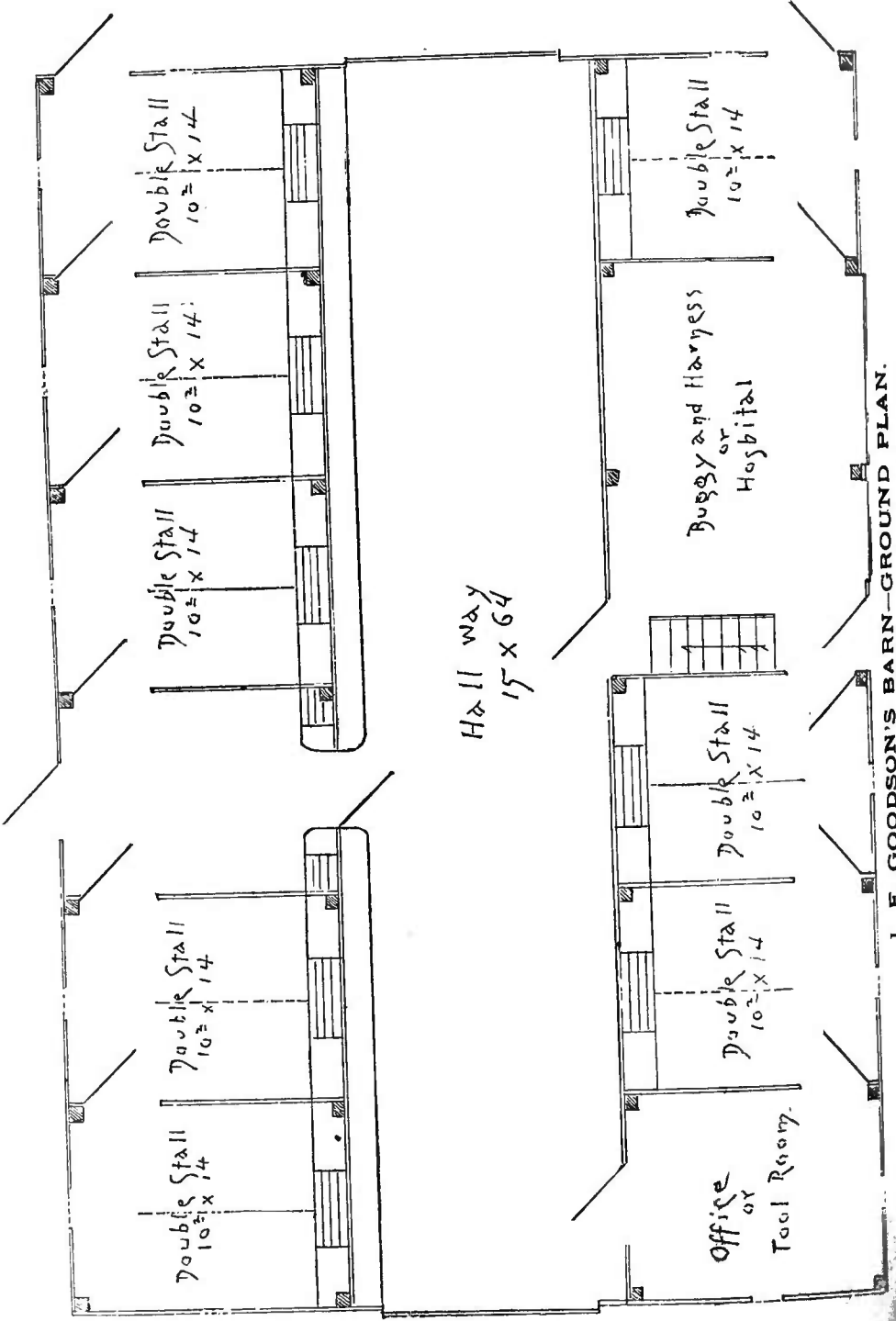

J. F. GOODSON'S BARN—GROUND PLAN.

chutes to be used below when necessary, and side holes to use in feed-room. Feed-grinder, corn-sheller, and feed-cutter are all run by shafting on this floor. On both sides are box-stalls 10x14 ft. with movable swinging bar in each to separate two horses when necessary. The hay-rack is open at the top, closed tight in front, and slatted on sides over trough, and on back over trough in hallway. Thus four horses eat hay out of one manger on right and two out of one on left.

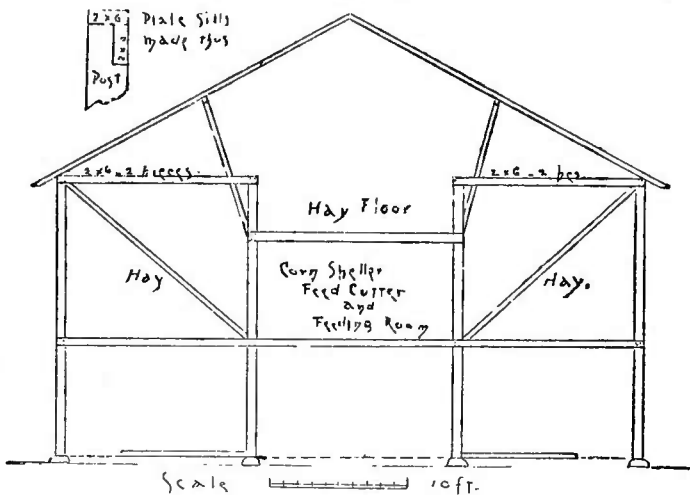

J. F. GOODSON'S BARN—FRAME WORK.

The bottom of the manger is level with the top of trough and slightly open to let seed through into seed-box below.

Everything is fed from above through openings left in floor the entire length of barn. The openings to feed-trough are hooded over three feet high. The hay is thrown over hooding into feed-room. Any hay bin can be left empty for cut feed. Thirty-six horses can be fed here without going down. I have used this barn for three years and like it very much. It is cheap, strong, and convenient.

J. F. RUNDLE'S BARN.

Mr. J. F. Rundle of Birmingham, Mich., has a very complete little horse barn which although not so large as many of the same cost yet is exceedingly tasty, well arranged, and

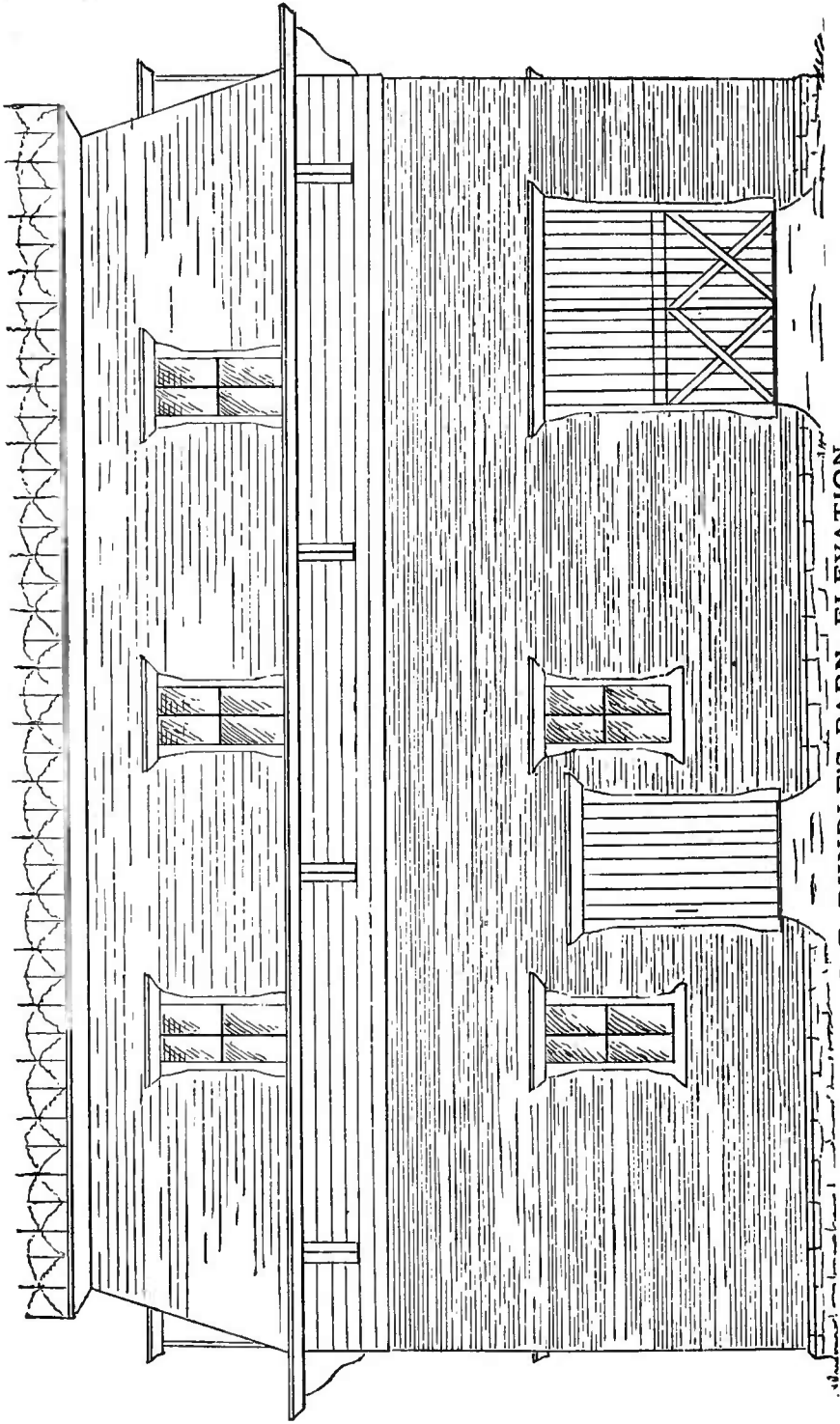

J. F. RUNDLE'S BARN - ELEVATION.

CARRIAGE and Tool Room.
14'6" x 30'6"

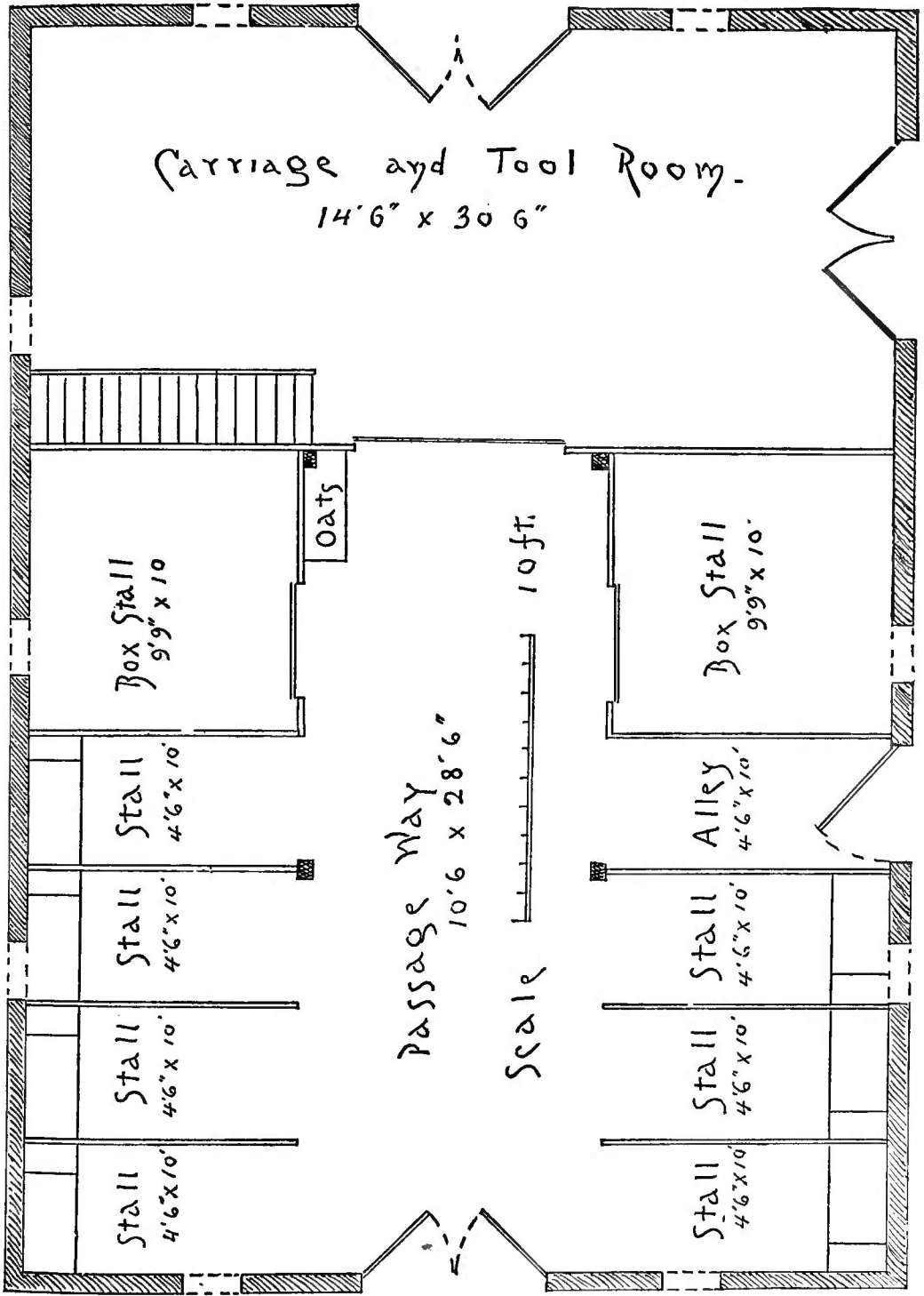

Box Stall
9'9" x 10'

Stall
4'6" x 10'

Stall
4'6" x 10'

Stall
4'6" x 10'

Stall
4'6" x 10'

Oats

Passage Way
10'6" x 28'6"

Scale 10ft.

Box Stall
9'9" x 10'

Alley
4'6" x 10'

Stall
4'6" x 10'

Stall
4'6" x 10'

Stall
4'6" x 10'

substantially constructed. It is built of brick, 32x45, with mansard, slate, and tin roof, and wide, projecting cornice and frieze. He states the cost to have been about \$1,200, estimated as follows: 45 perch stone foundation, at \$2, \$90; 42,000 brick, at \$750, \$315; 1,694 ft. slate roof, at 7c., \$118.58; 20 windows, at \$5, \$100; 9,000 ft. stuff lumber, at \$13, \$117; 3,000 ft. sheeting for roof, at \$12, \$36; 12 squares tin roof, at \$8.50, \$100; 1,400 ft. matched flooring, at \$20, \$28; 3,000 ft. lumber for stalls, etc., at \$16, \$48; doors, \$30; paint, \$30; carpenters, seventeen days at \$7, \$119; hardware, etc, \$68.42. Total, \$1,200.

NEBRASKA HORSE-IMPORTING COMPANY'S BARN.

The horse barn built by the Importing Draft-Horse Company of Lincoln, Neb., is probably one of the finest and most substantially-built stallion barns in the country.

It will be seen from the accompanying diagram of ground plan that the interior arrangement in the main consists of a wide driveway (24x152) with a row of boxes on either side. This splendid driveway affords a place for exercise every day in the year, being of such dimensions that the horses may be taken on a gallop if desired from one end to the other—and all horsemen understand the value of such a place when the inclemency of the weather prevents out-door exercise.

Another special feature is the construction of the boxes. The partitions between the boxes and abutting on the hall consist of a solid 4-in. wall of pine, made of 2x4 pieces laid like brick, one on top another, with a cap-piece of oak 5 ft. up. Above this for 3½ ft. more there is a grating of gas-pipe ¾ in. in size, outside measure, and 4 in. apart. To provide means of speedy egress in case of fire there is an outside door to every stall.

The foundation consists of a solid 18-in. wall, 18 in. deep; piers and interior posts are 18x18 in. and 3 ft. deep. The frame is a mortise and tenon: 8x8 stuff for posts, sills, and cross-beams; posts 22 ft. high. The first floor is dirt, and the second floor over boxes is matched flooring, and over hall common boards. Joists 2x10; 16 in. apart over stalls, 12 in.

NEBRASKA HORSE IMPORTING CO.'S BARN—ELEVATION.

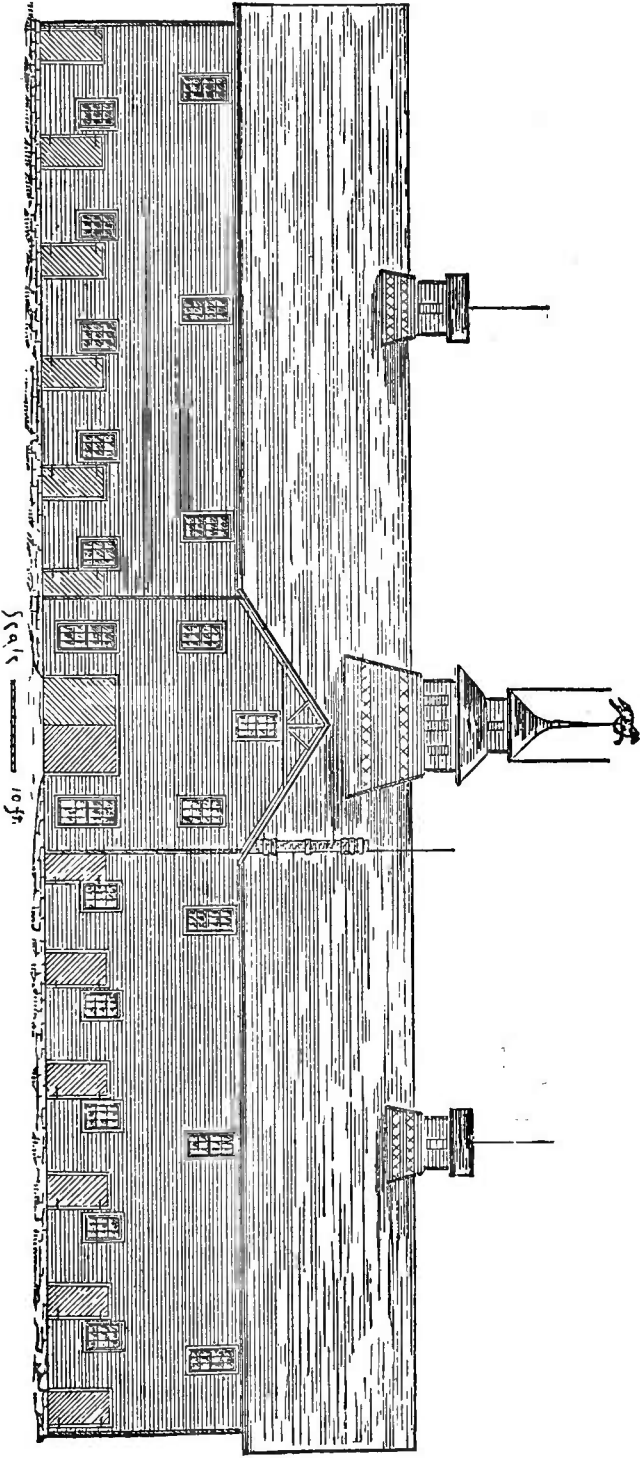

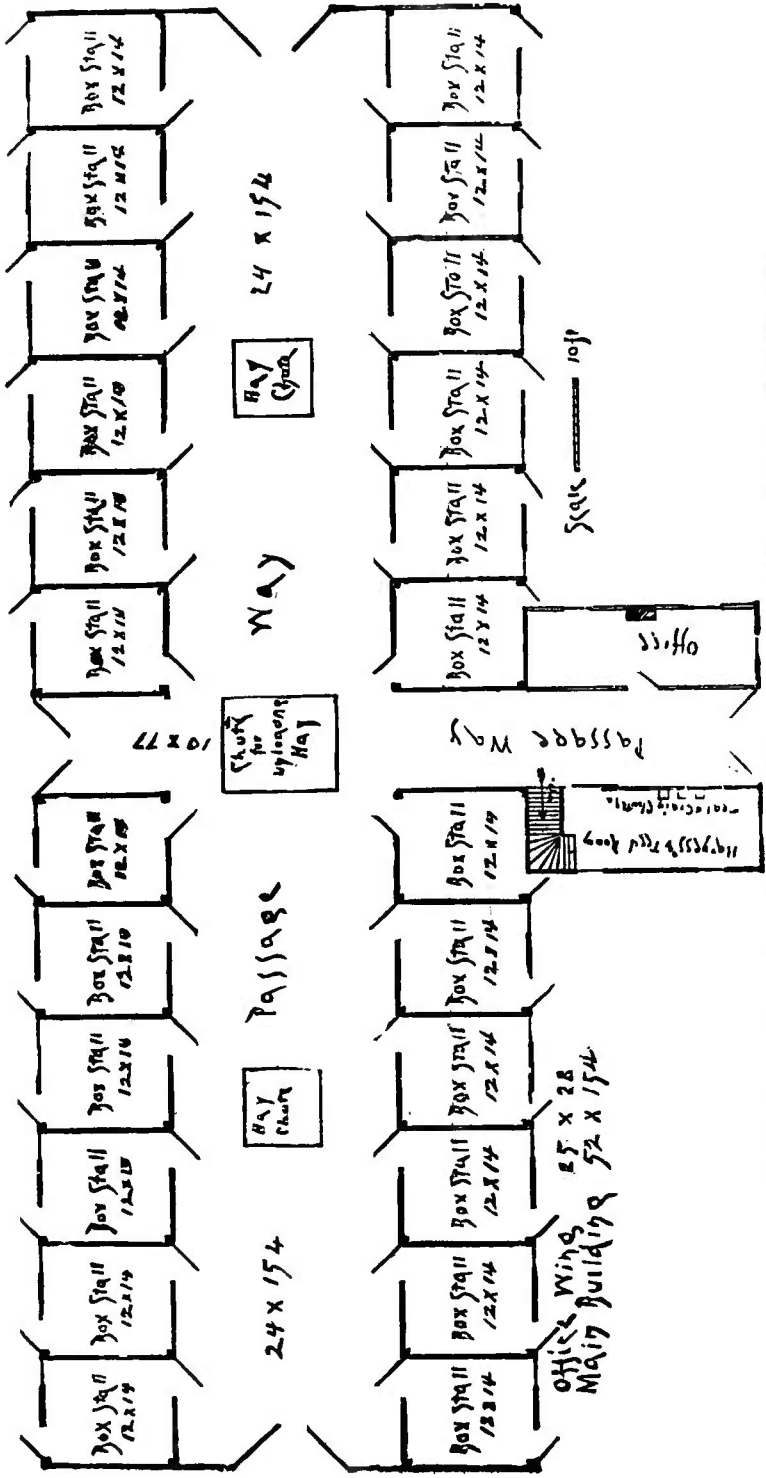

NEBRASKA HORSE IMPORTING CO.'S BARN—GROUND PLAN.

apart over hall. Sides 5½-in. patent siding. Rafters 2x8, 2 ft. apart, with 2x8 ridge-pole. Shingle roof, with eaves projecting 24 in. Stall windows have nine lights, and slide to one side. The hall and office windows have twelve lights

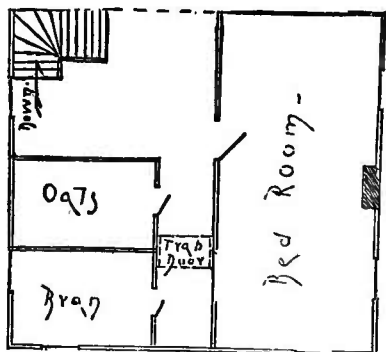

SECOND FLOOR PLAN OF OFFICE WING.

10x18, and second floor windows have twelve lights 10x14. The inside doors are of three thicknesses of ¾-in. matched flooring. There is a cellar nine feet deep under feed-room for carrots. The sides and ceiling of office-room are matched ceiling of pine, and in the second-floor room lath and plaster. The large ventilator is 10x10 ft., and handsomely proportioned.

The cost of this barn was probably between \$8,000 and \$9,000, the proprietors apparently having spared no expense in making it a singularly substantial, roomy, and well-ventilated stable.

M. RICH'S BARN.

The horse barn, plans and specifications of which are herewith given, was built by M. Rich of Flanagan, Ill., who says that he would not change it in any particular were he to rebuild it, and that it has been duplicated by his neighbors. The estimated cost is \$575, although Mr. Rich thinks it cost somewhat more.

The foundation is of blocks of stone about four feet apart laid on top of the ground, except about the box-stalls, where it is solid wall. Frame consists of 6x8-in. by 18-ft. posts with 8x8-in. sills and 6x8-in. plates and girts and two middle posts of 8x8-in. stuff, all braced and stayed. Joists are 2x8 in. and one foot apart. Floors are 2-in. plank. Floor of loft and floor and sides of grain-bins are of matched pine and the floor of boxes is dirt. Rafters are 2x6 in. and 2½ ft. apart. Roof one-third pitch. Sides of barn are boards planed and bat-

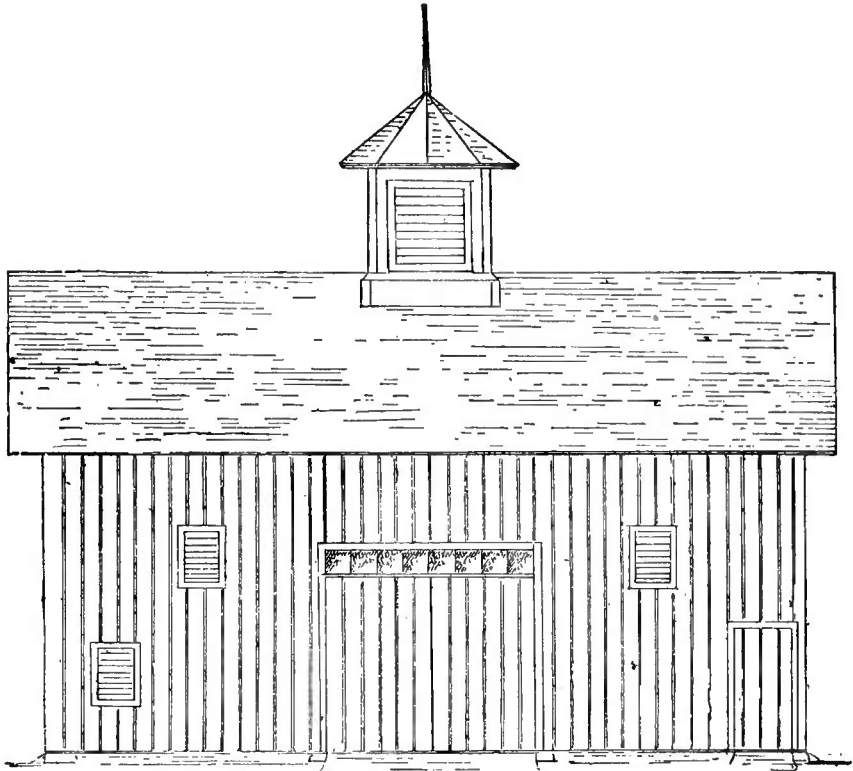

M. RICH'S BARN—SIDE ELEVATION.

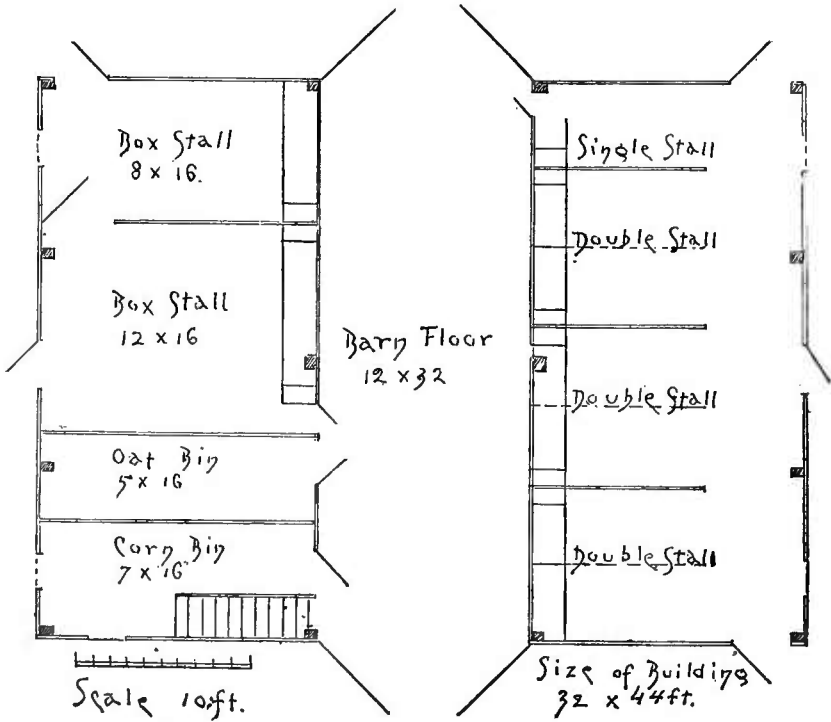

M. RICH'S BARN—GROUND FLOOR.

tened. The body of barn is painted red with white trimmings.

The expense items were as follows: Barn boards, 5,200 ft. at \$19, \$98.80; stuff lumber, 11,000 ft. at \$16, \$176; matched lumber, 1,800 ft. at \$20, \$36; sheeting, 2,100 ft. at \$14, \$29.40; shingles, 15,000 at \$3.50, \$52.50; piping, \$12.50; carpenters, hardware, glass, and paint, \$120; one car-load of stone from Joliet, \$27; 3,200 ft. battening, at \$5, \$16; incidentals, \$16.80. Total, \$575.

SHEEP BARNS, FEEDING RACKS, ETC.

WISCONSIN AGRICULTURAL EXPERIMENT STATION'S SHEEP BARN.

The plan of sheep barn in use for experimental work at the Wisconsin State Agricultural College is believed to embrace many features worthy of being generally adopted by practical sheep-breeders and several points that are vitally essential to successful sheep husbandry are brought out. The plan, which is mainly the work of Leslie H. Adams and herewith illustrated, is described by him as follows:

The erection of a building for the accommodation of sheep at the station farm was commenced in the fall of 1889; important additions having been made during the fall of 1891. It is believed that a description of the building now, embodying as it does improvements suggested by a two-years' experience with the part first erected, will not be without interest to many.

The building (see Fig. 1) consists of a main part 24x30 ft. two stories high, under the whole of which is a root cellar and two wings reaching out at right angles from it. The east wing is 125 ft. long, 18 ft. wide, and one story high. Only a part of this is shown in the cuts.

The south wing, to which we will now confine our description, is 100 ft. long, 18 ft. wide, and two stories high. An alley or passageway four feet wide is partitioned off along the entire west side of the building by means of a low fence-like partition (see Fig. 2). This leaves a space 14 ft. wide and a little over 83 ft. in length, exclusive of a lambing-room which will be described further on, that may be occupied by the flock as one large room, or it may be divided into any desired number of pens up to ten by means of a light but strongly-fashioned panel that rests in grooves made for it at

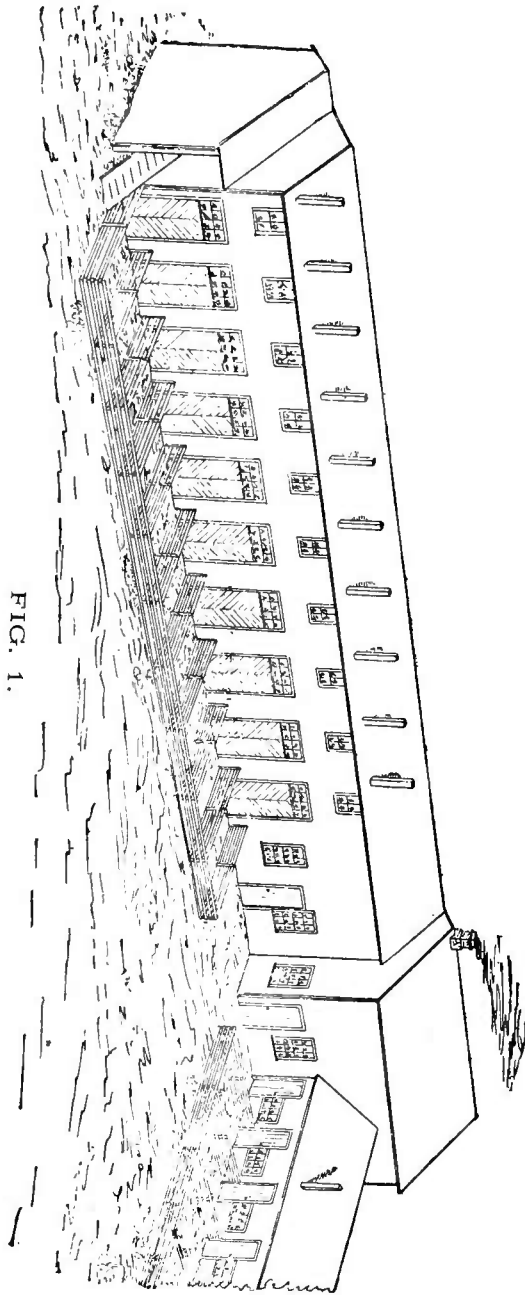
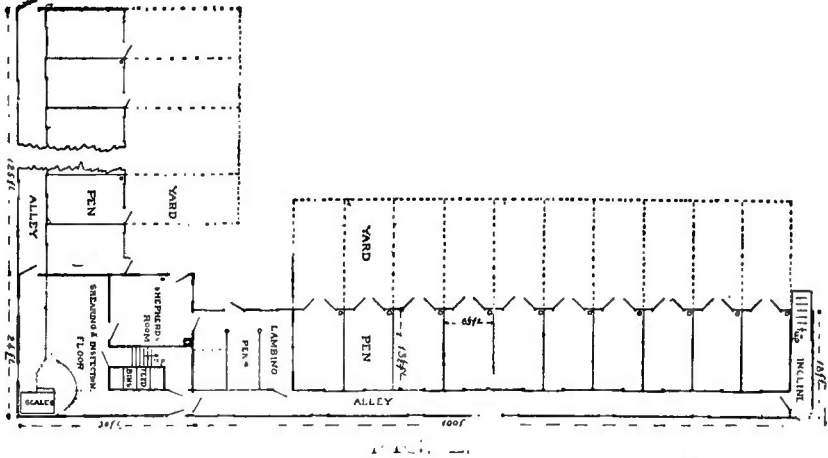

FIG. 1.

each end (see Fig. 3). These panels are easily managed and when placed in position are entirely secure without fastenings of any kind.



Since it has been explained how all the space in the shed may be used as one room, we will from now on consider the building as it is when divided into ten parts. Each pen is 8 ft. 4 in. wide and is entered from the passageway through a

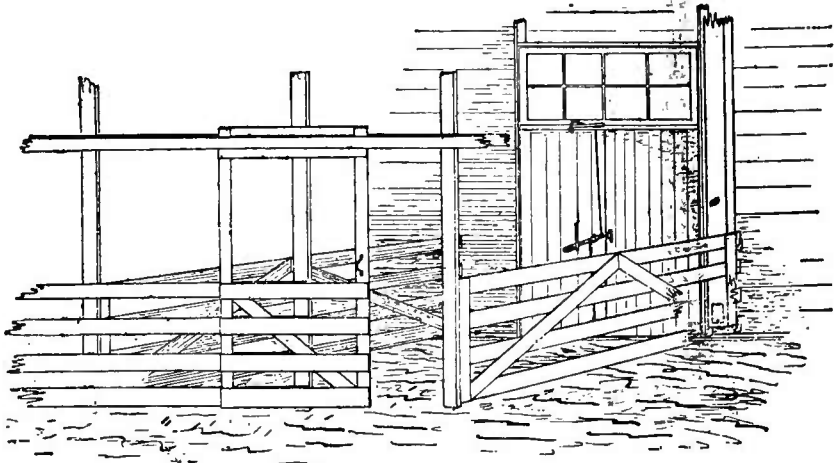

FIG. 3.

sliding gate (see Fig. 3) that is suspended from a 2x4 scantling which is fastened in a horizontal position to the upright pieces of the passageway partition.

Each pen is provided with a low flat-bottomed trough for

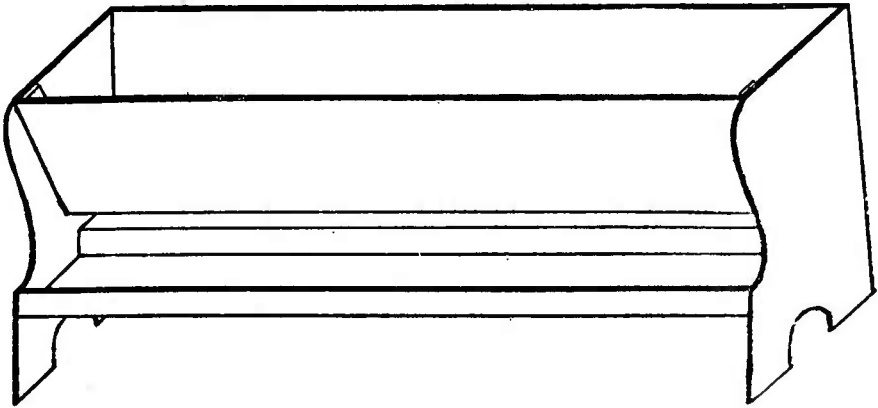

FIG. 4.

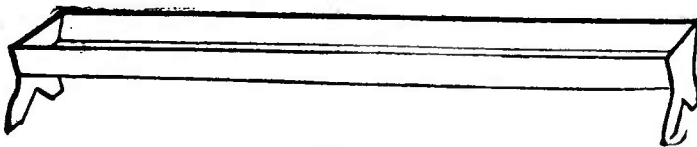

FIG. 5.

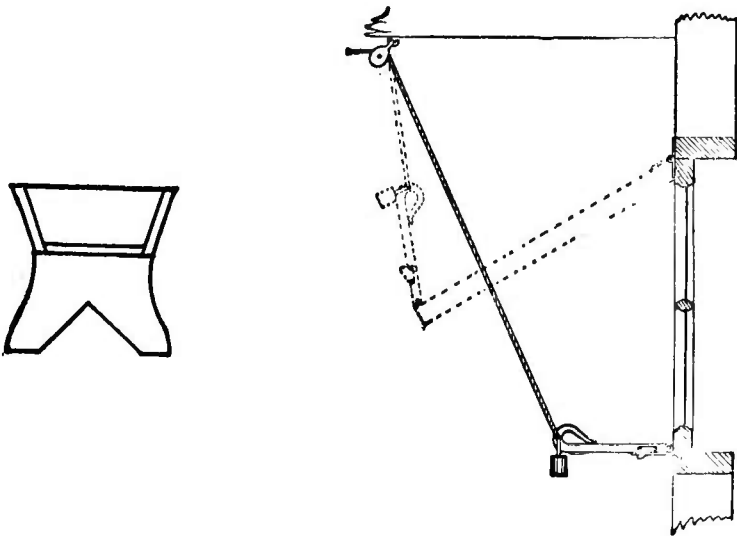

FIG. 6.

the feeding of grain, and also a large hay or fodder rack (see Figs. 4 and 5). This hay rack is made with a tight front which prevents chaff and dust from falling into the eyes and fleeee of the sheep while feeding, and is also adjustable so that not only the angle of the front but the width of the opening at the bottom where the sheep throw the feed out may be changed to meet the necessities of the feed that is being used. The feeder or trough that is below the opening where the feed is drawn out serves an admirable purpose in catching all the finer parts of the hay or fodder that would otherwise be trampled under foot and wasted. This hay rack, as illustrated in Fig. 6, is made to suit the conditions necessary for our experimental feeding, but it can be easily changed so as to meet the requirements of ordinary feeding by making it so that sheep can feed from both sides and long enough to reach across the shed. It may serve the double purpose of feed-rack and partition.

We now come to a point in the description of the building upon which I wish to place a good deal of emphasis, viz., the arrangement of outside doors and windows. Experience has taught that adequate ventilation must be provided in all sheep buildings if trouble in their management would be avoided, and it appears that the building that is best adapted to the successful care of a flock is the one that may be the most readily and completely changed from an open to a closed shed according as the weather makes one or the other of the conditions essential. In recognition of these necessities referred to, each pen has double doors that when opened out into the yard make an opening that only lacks thirty-eight inches of being as wide as the pen. The manner in which these doors are operated and fastened may be seen in Fig. 3. One door is bolted securely at the top and bottom by bolts operated by a lever as shown in the figure, and the other one fastened to it by means of an ordinary thumb-latch so that one or both doors may be opened at will. A slight upward movement of the lever allows both doors to swing open and when pushed shut a similar downward movement locks them safely.

Over these double doors are windows that are the same

width as the doors and two feet high. These windows are hinged at the top and are opened and closed from the passageway by means of a rope that runs over two small pulleys. The windows are provided with a fastening device (Fig. 6) that works automatically. A pull on the rope from the passageway unlocks the window and raises it at the same time. When the rope is released the window closes and locks itself. Since the windows are operated from the hallway time is saved and annoyance and confusion to the sheep prevented.

From what has been said it is easy to see how readily the barn may be converted into an open shed. If the weather is stormy but not cold the flock can be kept in the barn with the closed doors and the large windows left wide open, which will insure the admission of an abundance of fresh air without the bad results following the exposure to a draught directly upon their bodies. Should it become necessary to close the barn tight we still have ventilation by means of shafts that are constantly carrying off air from near the floor of each pen. These shafts (see Fig. 3) are simple wooden boxes that start a foot from the floor and extend up through the roof as high as the peak. They are made by nailing two eight and two ten-inch boards together. Near the bottom on one side of the shaft is an opening for the admission of air, the flow of which can be regulated by a door that is hinged at the bottom and pushed into the shaft.

A lambing-room occupies the space of two pens in the partition adjoining the main barn. It is 14x16 $\frac{3}{4}$ ft. This room is inclosed by tight walls on all four sides, with an outside door and a door leading to the shepherd's room. The wall next the alleyway and that next the first pen are provided with wide hanging-doors hinged above extending horizontally which reach from about two feet below the ceiling to a point four feet above the floor. In cold weather they are fastened down, at other times they are swung to the ceiling, leaving the pen light and airy. By means of movable partitions this will accommodate six or eight ewes at lambing time.

The second story of this barn is arranged for sheep also. The floor is constructed of one-inch matched material with

a coating of gas tar mopped on while hot. There are no permanent partitions of any kind up-stairs. The space is divided by means of light fence panels to suit the ever-changing conditions and requirements of our experimental work. The sheep in going to and from the second story pass up and down through a chute at the end of the barn (Figs. 1 and 2).

Before passing to a description of the main part, I will add that the east or one-story wing has a 4-ft. passageway along the north side which leaves a room 14 ft. wide by 125 ft. in length. This may be occupied as one room or divided into any number of pens up to fifteen, which is the maximum. The gates and panels are similar to those described in the south wing.

A reference to Fig. 2 will show that the main barn is arranged to be convenient for both wings. The scales are located in the corner where the passageway from the wings meet. By this plan the sheep may be let out from any pen in either wing and driven along the passageway to the scales. The shepherd's room is in the southwest corner and by means of small windows in the partition a view of the whole interior of both wings may be had. A door from this room opens directly into the lambing-room and if necessary the lambing-room can be warmed from the shepherd's room.

The dotted lines beside the shearing and inspection floor in Fig. 2 represent a railing three feet high that forms the passageway partition, and the space between this railing and the shepherd's room is used both as a shearing floor and an inspection room for the use of students while studying or judging animals. Feeding bins and stairways leading to the second story of the south wing and to the root cellar below occupy the balance of the space on this floor as shown in Fig. 2.

C. HILLS & SON'S BARN.

Mr. C. Hills of Delaware, O., who has a well-established reputation for rare good judgment in all his farming operations, has furnished us with the accompanying plan of basement sheep barn, which has for several years past been in

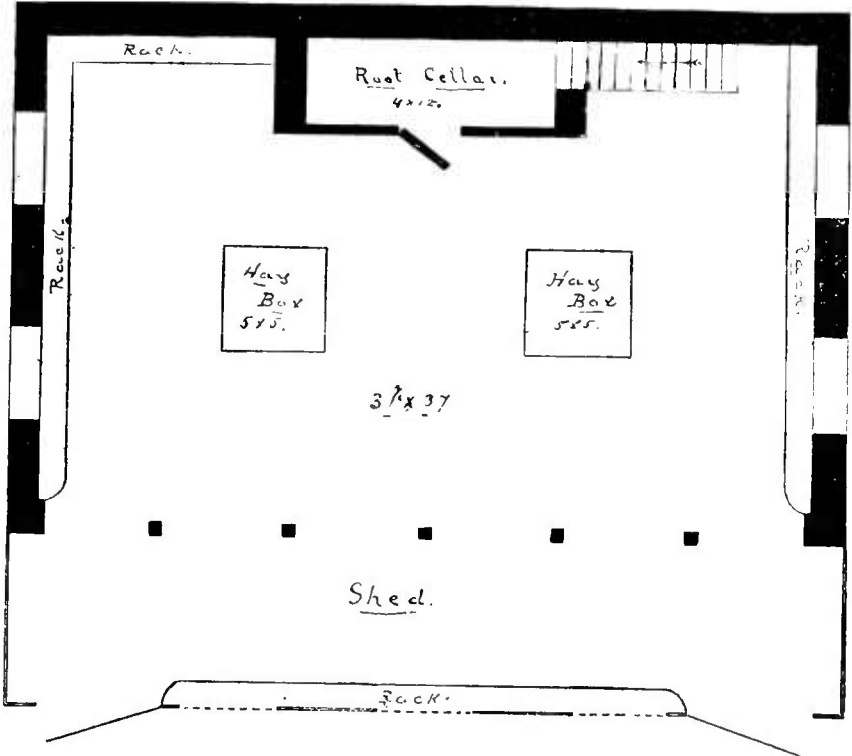

HILLS & SON'S BARN-BASEMENT.

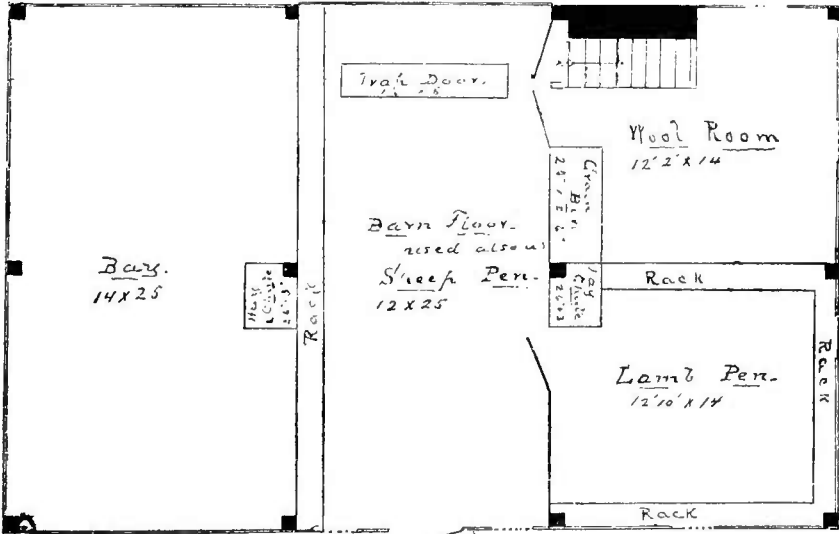

HILLS & SON'S BARN-SECOND FLOOR.

use on his farm and has given good satisfaction. The illustrations fully explain the plan and the building specifications are as follows:

Walls to be of stone up to joists of main floor eighteen inches thick and of suitable depth and thickness below ground. Frame to be of 8x8 stuff (except plate beams, which may be 7x7), put together with mortise and tenon and stayed with braces; girders between sill and plate beams. Besides the four corner posts there shall be one post at the center of each end and two on each side (as shown in plan) with cross

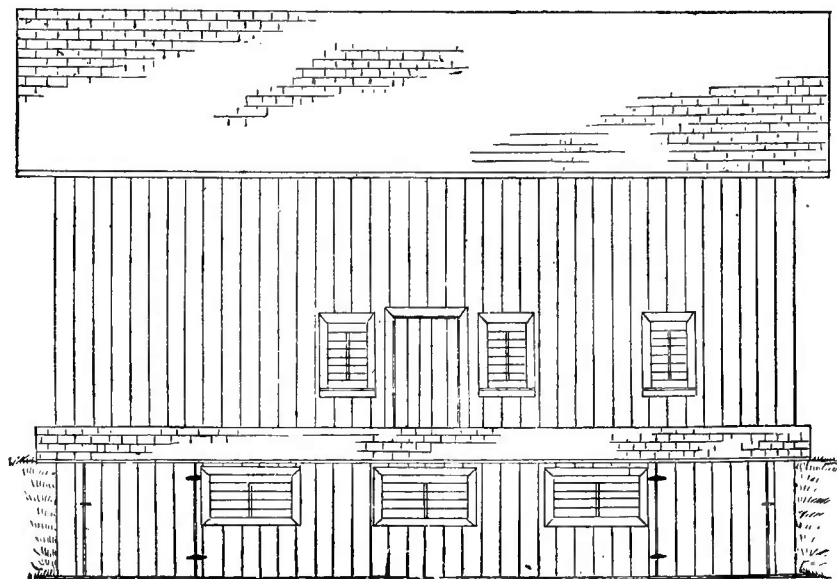

HILLS & SON'S BARN—SIDE ELEVATION.

beams connecting the latter. Rafters to be of 2x6 stuff, two feet apart, projecting two feet at eaves and gables. Joists of main floor to be of timbers hewn on two sides to six-inch thickness and three feet apart. Joists of loft to be of 2x6 stuff eighteen inches apart. Sides to be of twelve-inch barn boards planed on one side. Flooring of barn floor and lamb pen to be of two thicknesses of one-inch oak, lapped and matched. Floor of bay to be of matched flooring. Floor, sides and ceiling of wool-room to be of matched lumber. Floor of loft to be of matched flooring. Racks to be one foot from floor, two feet high and spaces for sheep to feed in six

inches wide and six inches apart. Roof to be one-third pitch. Basement elevation 6 ft. 6 in., floor to joists.

Bill of expense: 94 perches of stone, at \$1.50, \$141; excavating 111 cubic ft., at twenty-five cents, \$27.75; 800 ft. rafters, 532 ft. loft floor, 3,072 ft. beams, 267 ft. beams, 128 ft. braces, 350 ft. girders, 956 ft. hard-wood floors, 1,162 ft. matched lumber, 2,643 ft. barn boards, 360 ft. racks—10,270 ft. at \$16, \$164.32; 13,875 shingles, at \$4, \$55.50; carpenters, 10½ days at \$7, \$71.75; 1,440 ft. sheeting, etc., \$33; 13½ M shingles at \$1.50, \$20.63; nails, glass, hinges, etc., say \$86.05; total, \$600.

These prices for material and labor are those now ruling in Central Ohio; and by altering the same to conform with figures obtaining in other given sections of the country an exact estimate of the cost of reproducing the building can be had.

E. M. REES' BARN.

Mr. E. M. Rees of Franklin, Ill., a flockmaster of much experience, describes the sheep barn which has been in use upon his farm for some years past so clearly that no illustration is needed to make it perfectly plain to any one of average intelligence. His barn is especially designed for Cotswold sheep, which require about one-third more space than the smaller breeds. The barn is described by him as follows:

Our barn is 32x30. In the centre there is an alley, four feet wide, the length of the building; on either side of the alley there are small pens, say 4x5 feet, with doors to each that will reach across the alley, making a stoppage at each pen. The pens are each provided with a rack for hay and box to feed, also a movable box for watering, hung at any desired height by two small hooks that slip over the edge of the partition planks, which need not be nearer than three inches, so the lambs will not mix. We place the ewes in the pens before they drop their lambs, and keep them in the pens until they get old enough to take care of themselves or until we want to use the pens for another set of ewes. We then put them in one of the divisions, which is 8x32, keep-

ing them in nights and stormy weather, giving them the run of a warm, sunny lot in the day time. On either side of the lambing pens there are two separate apartments, 8x32, with racks and troughs in the centre of each. The hay comes down from above falling directly into the racks. The racks are made with three-inch slats, three-inch space, four feet high, and stand perpendicular in front of the sheep, which keeps the hay seed from getting into the wool. There is a trough six inches square at the bottom of each rack to feed grain. Each division will accommodate about twenty ewes; but they are somewhat crowded. They require about 2x8 ft. space, which will give the shepherd room to pass behind them while they are eating to examine their udders, thus enabling him to draw out any that should go into the lambing pens.

The outside of the building is 44 ft. wide by 32 long, and inclosed with dressed boards battened and painted. Each division has a door in each end to close up in cold or stormy weather, with a gate to confine the sheep in good weather. There is a passageway from one division to another, enabling us to feed or change the sheep from one department to any other without going out of doors. There are five slide windows in each end and four in each side. There are no partitions more than four feet high, which leaves the space all open above to the loft. There are four feet taken off one end of the lambing pens for a feed bin. This holds 400 bushels of shelled corn or oats, which generally feeds the ewes during lambing time. The lambs are fed separately as soon as they get old enough to nibble, and are weaned about the 1st of August.

WILL R. KING'S SHEEP YARDS.

Mr. Will R. King of Marshall, Saline Co., Mo., has an extensive sheep farm, the divisions of which into yards and the arrangement of the stables upon the same are well shown in the accompanying diagram. It is arranged to accommodate about 350 head of sheep of the long-wooled breeds.

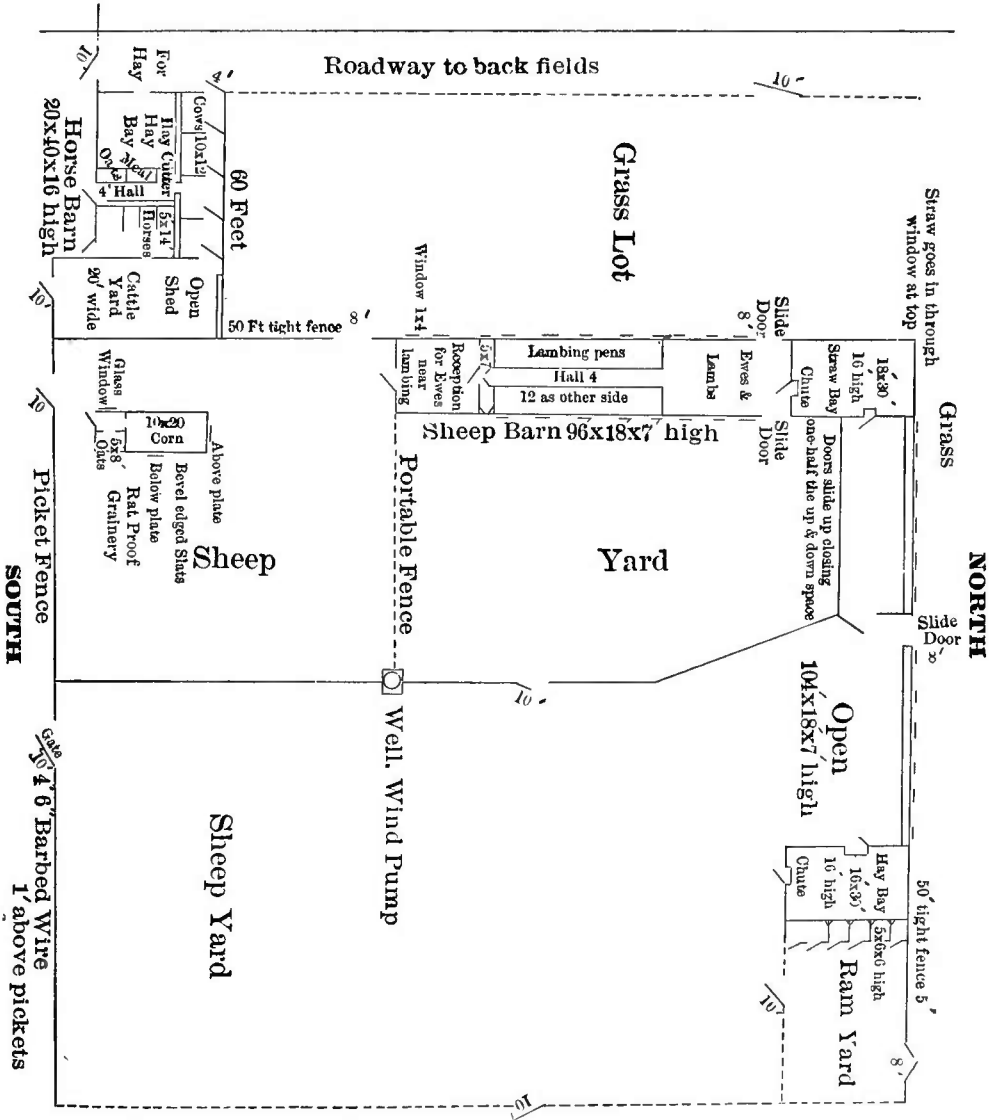

The buildings are neatly and substantially built of the best material and well painted. In building No. 1 there are twenty-four breeding pens 4x7, 4 ft. hall between the two rows, the gates of pens reaching across the hall. At each end of the building there is a room to receive the ewes as they enter and leave the pens. Building No. 2 is in two rooms, one open to the south and other half closed by doors sliding up and down. A stationary rack and trough extends full length on north side and movable racks with troughs are placed through the center. Buildings 3 and 4 are hay and straw barns. Building No. 5 is a ram barn with six stalls. No. 6 is a rat-proof granary. No. 7 cistern. A number of dog-proof lots surround the barns.

DEVICE FOR DIPPING SHEEP FOR SCAB.

Mr. Arthur O. Fox of Oregon, Wis., who has had large experience as a practical flock-master, describes the device in use on his farm for dipping sheep to cure or prevent scab and other skin diseases as follows:

Fig. 1 is the dipping-tank, made of 2-in. plank.

Fig. 2 is a cross-section of same.

Fig. 3 is the dripping-floor, made of matched flooring.

In Fig. 1 it will be seen that the tank is to sink into the ground about 12 to 18 in. or it may be set on top of the ground and an elevated platform built about it to make it the right height for men to stoop over the edge of the tank conveniently and to admit of driving the sheep from the crowding-yard or pen at H into the approach of tank at A. The crowding-pen and approach A should be on the same level. B represents the tank proper, which should be filled up nearly to a level with the approach A. C represents the exit from tank on to the dripping-floor D, which should be set at an incline to the tank so as to drain back readily into the tank.

The dripping-floor D (Fig. 3) is divided by a partition with a swinging gate at the end next the tank, so hung as to swing to either corner of the tank. By the use of this little

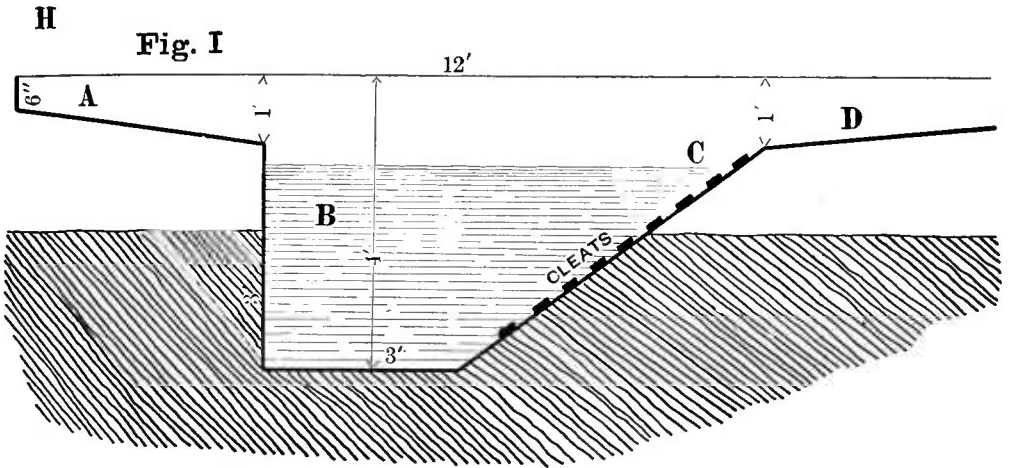
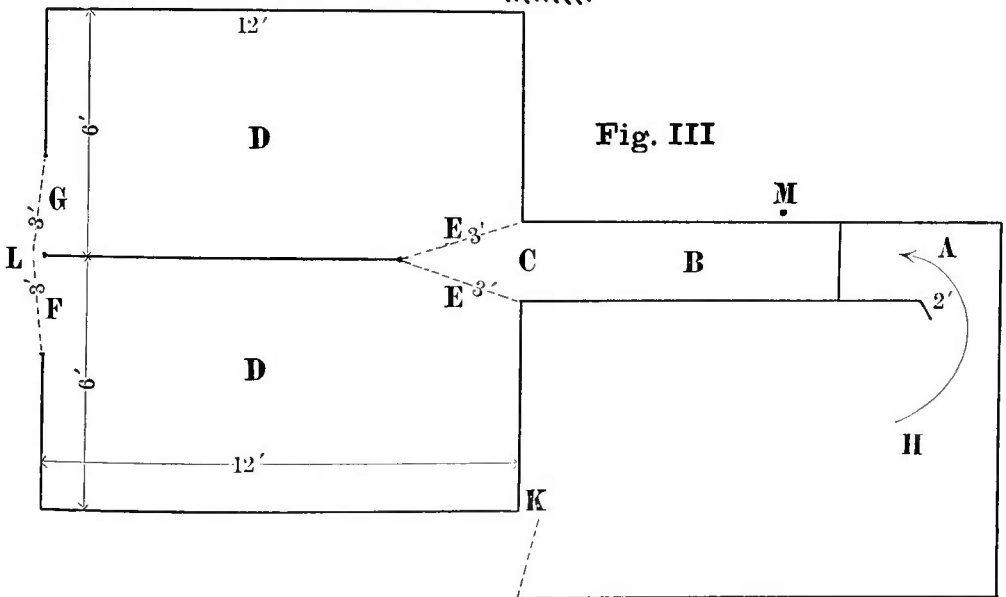
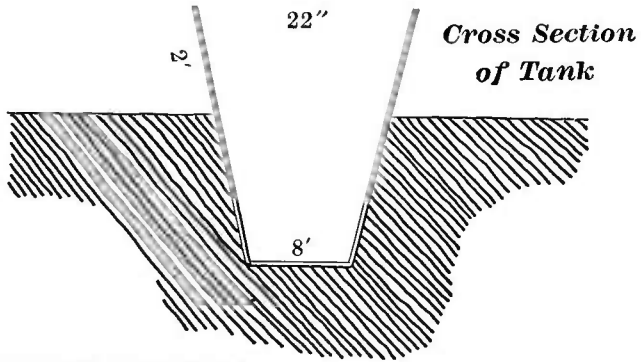

Fig. II



gate one side of the dripping-floor is filled with twenty sheep or more which stand and drip while the opposite side is being filled. The first pen filled is then turned out into the sheep-yard L and refilled with fresh sheep from the tank while those in the opposite side are dripping, and so on.

F and G are the exit gates by which the sheep are put into the sheep-yard I. K represents a gate opening into the crowding-pen H from another sheep-yard which holds the undipped sheep awaiting their turn.

This crowding-pen should not be over 12 to 16 ft. square for ordinary flocks of several hundred.

SHEEP CORRAL AND SHEARING PENS.

The arrangement herewith described and illustrated has been found well adapted to the needs of sheep "ranchers" on our great Western plains and mountain ranges, and a gentleman of large experience furnishes the following description of its use as well as of the method of shearing and taking care of the wool generally practiced:

The panels used in building corrals are made of pine lumber twelve feet long and six inches wide. Five planks are used to the panel with three cross-pieces, one at each end and one in the centre, the panels when completed standing four feet high. To set them up, stakes are driven into the ground and the panels tied to the stakes with a small rope. The "shepherd's knot" is the best knot for this purpose.

Referring to the diagram the chute *EF* is eighteen inches wide, and is about thirty feet in length. At the end is the "dodge gate," which is hinged to the post at *a* and swings against a post at *b* or *c*. The post to which the gate is hinged (*a*) should be in the line of the fence and not in the centre of the chute. The majority of the sheep run through the straight chute. The dodge gate is made to swing easily and is about five feet wide. The gate-keeper stands in corral *A*, and if the sheep are unused to a chute he is concealed by a wool sack hung on the panel of the chute. He cuts out unshorn sheep until the corral *A* holds a sufficient number to last the shearers until 11 o'clock.

The corral *A* leads to the lane *B* by removing the panel *g h*. The lane is run full of sheep. It is six feet wide.

The shearing pens, of which *C* may be taken for explanation, are twelve feet square (the length of one panel). A platform, *m, n, l, r*, is made nearly on a level with the ground and is five feet wide and twelve feet long. Two shearers occupy each pen. The panels forming the lane do not overlap but are set end to end. When the sheep in a pen are shorn they can be turned from the pen across the lane out upon the range. They are counted as they run out by the "party of the second part" as opposed to the shearers who count the strings with which each fleece is tied.

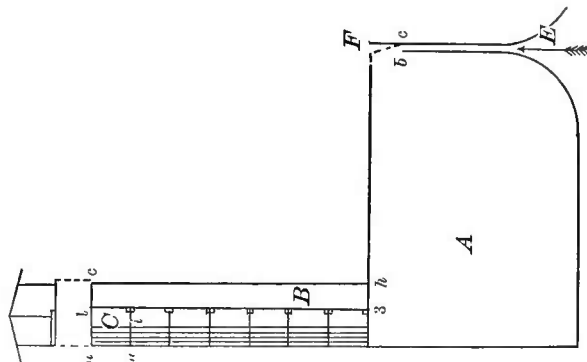

SHEEP CORRAL AND SHEARING PENS.

The shearer has two or three pairs of shears which he keeps very sharp, whetting after each fleece is tied. His shears while not in use are placed in a can of water which cuts the yolk of the wool from their blades and thus keeps them from being gummy. He catches a sheep by the hind leg, pulls it back to the platform, and with a slight push with his right hand near the sheep's saddle turns it over on its side, then a pull by his other hand turns the sheep on its back. Then letting loose the hind leg the shearer lifts the sheep by its front leg to a sitting posture and stands behind it; his left hand on the sheep's nose bends its neck back and it rests over the shearer's left leg. He makes a flourish with his right hand, in which the shears are held (if he has admirers watching him), and then begins.

He cuts from the sheep's front (right) shoulder-blade up-

ward to behind the right ear. He continues his strokes, beginning down and running up, until the under part of the neck is sheared. Then the shearer changes the position of his right leg so as to stand astride of the sheep's right front leg. By this means the sheep is turned slightly and the man is now in position to shear the left side. Beginning where he left off he cuts successive swaths, which may be termed horizontal, around the sheep's body, and which begin so as to include the legs and end at an axial line drawn down the back. Then the man stands on the sheared side of the sheep and bending it over his knee completes the shearing in a similar manner. He then folds the fleece, the sheared side being the outside of the folded fleece, and ties it with a stout twine. The tags he sweeps into a heap and piles them in a corner. They are afterward placed in a sack by themselves and the sack so marked. He catches another sheep, seizes another pair of shears from the water-can, and begins anew. The shearer receives seven cents for each sheep shorn. He sheares from 100 to 150 sheep a day, the number depending on the kind of sheep sheared. Merino rams of pure blood are the most difficult to shear on account of the wrinkles and the closeness of the wool. The men eat dinner at 11 o'clock and then work until 5 o'clock, when they eat supper and after supper continue work for two hours. The sheep are brought in at noon and the lane again filled with enough sheep to last the shearers the remainder of the day.

Each fleece is thrown by the shearer into a pen next to the shearing-pens. The wool is kept off the ground. The sacker then takes the fleeces and throws them up to a platform, but I will first describe the arrangement for holding the sack. A platform four feet square, made of stout planks, is set on legs about nine feet above the ground, and a circular hole cut in the platform, the diameter of which is an inch less than the diameter of the sack-ring. The sack-ring is made of iron about three feet in diameter, and the cross section of the iron would be a square with sides a half-inch in length. This ring will rest on the edge of the round hole in the platform. The wool-sack has a bunch of wool, or two walnuts

would be better, tied in the lower corners to serve as handles when the sack is full. The sack is then soaked in water until thoroughly wet. Then the ring is slipped in about an inch from the upper end of the sack and the edge folded under the iron. It is not sewed or tied in.

When the sack is hung in position the sacker throws in several fleeces and gets in and jams them down. He then puts in three fleeces, or as many as the sack will chamber, and treads down the outer edge, putting a fleece in the middle as required. Thus he continues until the wool is on a level with the ring. It is then full enough. He lifts the sack six inches by means of two ropes, which fastened in a hole in the platform pass down under the sack and up again to the platform, where they pass through holes and are wound on top of the platform on a windlass. The sacker lifts the sack without having to descend and holds it there by placing a pin in the axle. He then unfolds the ring and sews up the end of the sack, beginning at the middle seam and using a "surgeon's" stitch, by which contiguous stitches hold independently of each other. He puts about 300 lbs. in a sack.

ANOTHER DEVICE FOR DIPPING SHEEP.

A device for dipping sheep for scab and other skin diseases, differing somewhat from that described on pages 166 and 167, and which is extensively employed on the large sheep ranches of the Western plains, is herewith given, together with the mode of procedure as described by a Western flock-master of large experience.

Sheep are dipped soon after shearing in the spring or in the autumn, and sometimes in midwinter when the scab is bad and the weather is mild enough. The method of dipping here described is the one used where it is necessary to boil the dip. For cold-water dips the mixing vats are differently arranged but all the remainder is the same.

The lane *L* is one panel, 16 ft. wide, and is long enough to hold 500 sheep. Its length is not given in the diagram for

want of space. The large corral *A* which leads to the lane by the gate *m n* has one side in continuation of the fence *m b*. The undipped sheep are held in this corral. The corral *C* has a plank floor which slopes at an incline of 10 per cent from its outer edge down to the floor *b c d*, which is level. This inclination is of great assistance in the handling of the sheep. The vat is protected by a planked wall, as shown in elevation at *b d*. The vat *V* is 50 ft. long, 8 ft. wide in the clear at the bottom, 18 ft. wide at the top, and 5 ft. deep. The dip in it is kept 4 ft. deep. At the farther end, at *r s*, the sheep walk out on an incline with strips nailed across for footing. At *g* is hinged a "dodge" gate which turns the sheep as they walk out of the vat either into the corral *D* or *D*. From either of these corrals the sheep are turned into the large corral *B* through the gates hinged at *I*. The corral *DD* has a plank floor, strips nailed as shown and is partitioned by the panel *g h*. The corner of this corral at *i* is three feet higher than the corner at *s*. The dripping sheep stand on the floor *D* and the dip runs back into the vat.

The boilers are of the dimensions given. *F* is drained by a pipe leading to the *bottom* of the vat *V* and provided with a stopcock. It is important to conduct the boiling dip into the vat at its bottom in order to quickly heat the dip in the vat when the dip becomes cool, to make it of uniform temperature and to prevent scalding the sheep. *G* contains boiling water which is led into the lower boilers by means of wooden troughs *t t*. A water ditch leads to the top of the boiler *G*. The head of water required above the bottom of the vat *V* is, as shown, about 7 ft. 4 in.—and the stream should not run less than three gallons a minute. In each of the boilers *FF*, on the inside, nails are driven or other marks made to denote the height when 100 gals., 200 gals., etc., and convenient fractions thereof, are reached by the dip. The chemicals are mixed in these boilers only and the upper boiler is used for keeping boiling water always ready.

The vat being ready and a glowing fire under the furnaces the sheep are run from corral *A* into the lane and into corral *C* until both are full. Then the gate at *m* (consisting of a panel) is closed against the posts and that at *a* also. Two

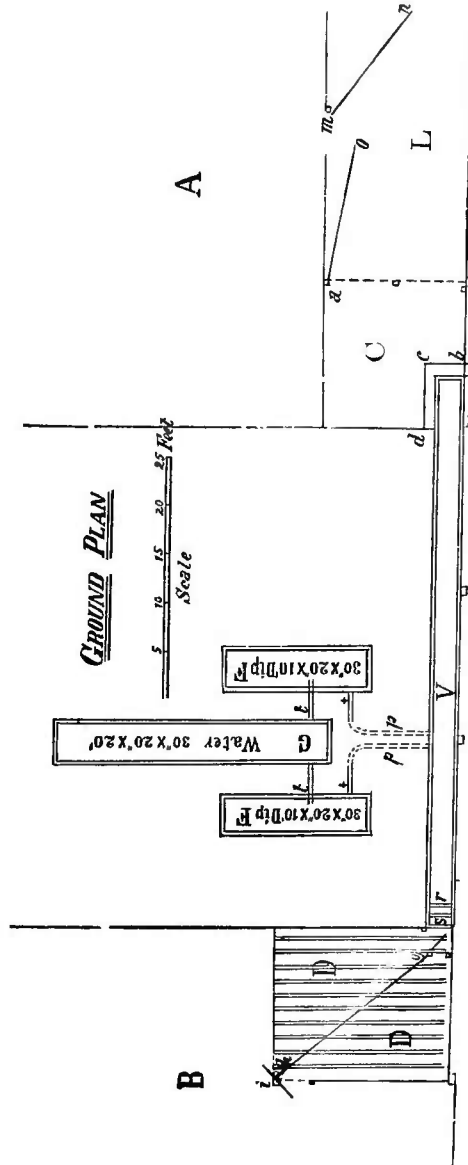
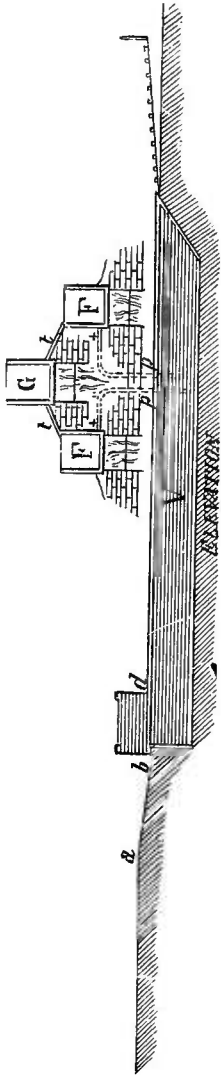

men in *C* throw the sheep into the vat. A sheep is caught by the right hind leg below the hock, lifted up until straight, then the man walks to the vat, the sheep walking on its front legs, then by a push by his right hand above the sheep's flank the man throws it against the wall *b d*, when its feet being no longer supported it falls head first into the dip and immediately swims toward the other end. A man along the vat between *V* and *d* thrusts its head under again with a forked stick as it passes him, and another between *V* and *r* treats it in the same manner. These two men exchange places with the two in the corral *C* every hour, since the labor of throwing sheep in is severe. One man attends to the fires and keeps the dip always ready and at proper temperature. Five men are necessary and usually run through 2,500 sheep a day. The sheep, though badly frightened, are not hurt if the liquid in the vat is never allowed to become too hot.

SHEEP-FEEDING RACKS.

The device herewith illustrated has been extensively used in the great sheep-raising districts of Pennsylvania and Ohio and is very much liked. It was at one time secured by

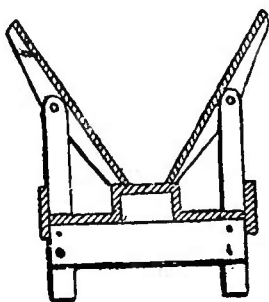

SECTIONAL VIEW OPEN.

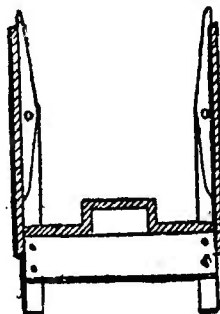

SECTIONAL VIEW CLOSED.

a patent and a considerable royalty was exacted for its use, but the patent has expired and it may now be made by anyone. The diagrams explain it fully. It is so constructed that when closed one can pass through the rack and distribute the grain in the triangles, preventing a few of the

stronger sheep crowding after, bunching and gobbling the grain, as they will do when poured into an old-fashioned V shaped trough. After the grain is placed in the troughs the wings, which are hung upon pivots, are turned down, and the sheep all pass to their grain at once, each one getting an equal portion; the wings which then slope together form the hay-rack, the sheep drawing the hay from an opening at the bottom.

There are no stanchion slats to wear the wool from the neck and shoulders, no chance for chaff to work into the wool, nor for the sheep to waste their hay. A small door, hinged at one end of the rack, makes it easy to sweep the dirt out of the troughs. Height of posts, 31 in.; size 2x3 in. Length of arms, 30 in.; size, 2x3 in. Width of boards on arms, 27 in. Width of frame, 30 in.; width of trough, 10 in.;

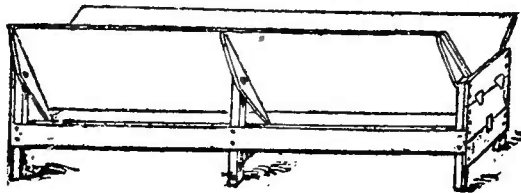

SIDE VIEW OF SHEEP-RACK.

width of walk, 10 in.; depth of trough, 4 in.; distance from short end of arm to center of bolt, 13 in. The bolt should be one inch from top of posts. Width of board on sides, 7 in.

Another rack quite similar to the preceding one was patented by a citizen of Wisconsin several years ago, and this patent has also expired, so that the plan which we illustrate herewith has become public property. As will be seen from the illustrations herewith given it has its roof and division boards hinged or pivoted in such manner that the frame can be opened and placed so as to shield the trough when the device is to be used as a cattle-feeding rack, and so that the roof may be closed and the division board thrown up, thereby affording free access to the troughs when the device is to be used as a sheep-feeding rack.

By referring to the drawings, which represent cross sectional views, it will be seen that the troughs are connected by a horizontal bottom board running lengthwise along the

rack. To the bottom are hinged two division boards or doors. These are shown in Fig. 1 as thrown up toward the center of the device, and in Fig. 2 as let down to cover the troughs.

To the sides of the frame are pivoted two boards, which constitute the roof when it is used as a sheep-feeding rack, as shown in Fig. 1, and as additional sides when the device is used as a cattle-feeding rack, as shown in Fig. 2.

It will be noticed that when the device is adapted for feeding sheep the pivoted boards form the roof, and the division strips, hinged to the bottom board, constitute the back

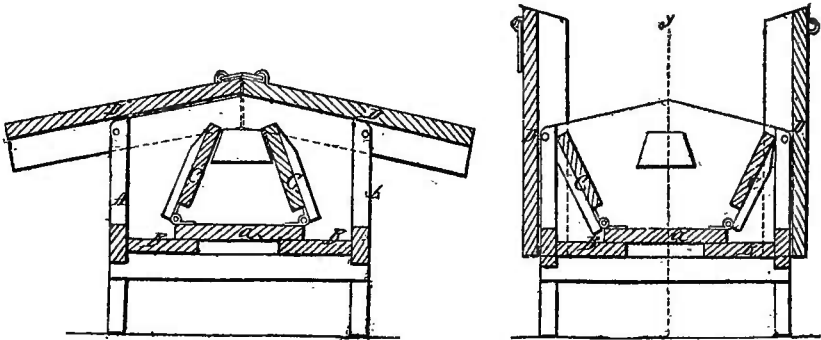

FIG. 1.

FIG. 2.

of the troughs, they being thrown inward on their hinges toward the center of the device. On the other hand it will be seen that when the rack is adapted for feeding cattle the roof boards are thrown up along the side of the device so as to increase the capacity of the bin for holding hay, and yet not extending high enough to prevent the cattle from reaching over. The pivoted trough boards are then thrown out against the sides of the rack so as to enclose and shut off the troughs.

A very convenient device for sheltering and feeding sheep, upon which letters patent expired in February, 1885, is herewith illustrated. It may be easily made by almost anyone. The shelter consists of a light framework of wood of a size adapted to the number of the flock, and is constructed and put together in sections. The shed is mounted upon runners for the convenience of moving it from place to place for the purpose of feeding the sheep. It will be seen

that the racks are arranged along each side of the shed and open on the inside. The troughs are on the outside of the shed and are covered with a drop-cover, thereby protecting the provender given the sheep from the storms of rain and snow.

By this arrangement of the racks and troughs the animals while feeding are sheltered from storms and kept in better health and condition by being thus comfortably housed. As the feed is given them from the outside of the

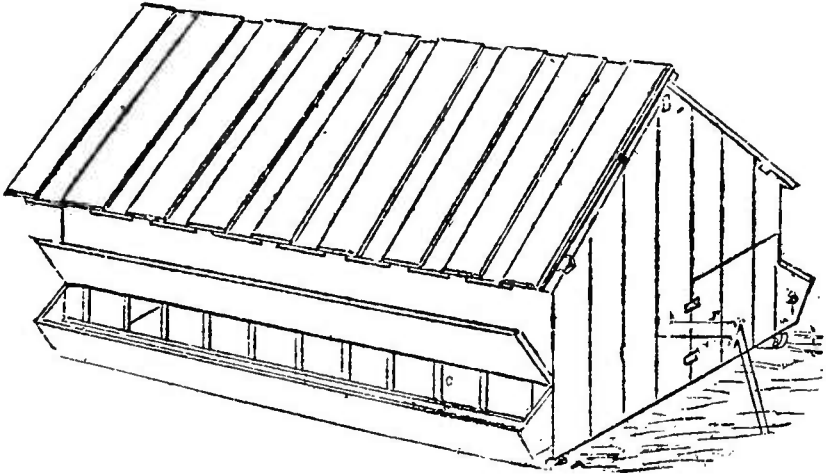

shed the flock is not disturbed by the presence of those caring for them, it being a matter of much trouble and inconvenience to pass in among a flock if it is large.

The shelter being made in sections it may be easily taken down and placed upon a wagon for transportation; or the sections may be used for other purposes, as fencing, etc., when not in use.

By removing the light roof sunshine can be let in upon the flock in fine weather when they are required to be kept confined for the purpose of fattening, sorting, and the like.

A PLAIN HAY-RACK.

A very convenient, plain, and easily made hay-rack for feeding sheep is shown herewith, and is made as follows: Four pieces of scantling 3 ft. long for corner posts, two boards

1 ft. wide and 16 ft. long for the bottom, and two 6 in. wide and 16 ft. long for top, with 6-in. boards $2\frac{1}{2}$ ft. long, placed 8 in. apart, perpendicular; the space between the top and bottom boards on each side is 18 in.; the width of rack should be $2\frac{1}{2}$ ft. When the hay is properly put in this rack the sheep eat from the top of it, avoiding the falling of dirt into the wool on the neck. The upright strips keep the sheep from crowding, and knowing this a sheep takes its position and keeps it until through feeding. The following diagram may

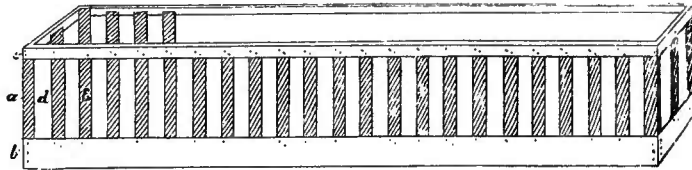

aid in getting a correct idea of this simple rack. (*a*, corner post, 3 ft.; *b*, bottom board, 12 in.; *c*, top board, 6 in.; *d*, 8-in. spaces; *e*, 6-in. uprights.) It will answer for a partition fence and can be elevated daily as the litter and manure accumulate.

SWINE PENS.

The whole subject of pens and devices for breeding and feeding swine is so thoroughly and exhaustively gone over in connection with the various plans herewith submitted that any remarks of a more general nature by way of introduction are entirely superfluous. It is no more than justice, however, to state that a considerable number of them are from designs originally furnished or suggested by that experienced practical breeder and close observer, the late Phil M. Springer of Springfield, Ill., who was for so many years the efficient Secretary of the American Berkshire Association. Prof. L. N. Bonham of Ohio, so well known in Poland-China breeding circles, has also furnished several plans and devices which will be found herein, and the experience of many other swine-breeders of note in various parts of the country from Pennsylvania to Nebraska has been utilized in the preparation of what it is hoped will be found an invaluable assistant to every swine-breeder who may consult this volume.

STREET & SON'S SWINE PENS.

The accompanying plan, which was designed by and is used by Messrs. Street & Son of Hebron, Ill., is considered by many persons one of the very best pens for swine in the country. The building is 30x64 ft., with 9-ft. posts. The ground plan is divided into eight apartments each. The first or front space is intended for a water tank, which is supplied from a well. In the same space is a stove for heating purposes. A 4-ft. alleyway runs the entire length of the building. At the rear end is the corn-crib. There are six pens on each side of the alleyway, each pen having a nesting place of 6x6 ft. Size of pen, including nest, 8x13 ft. The

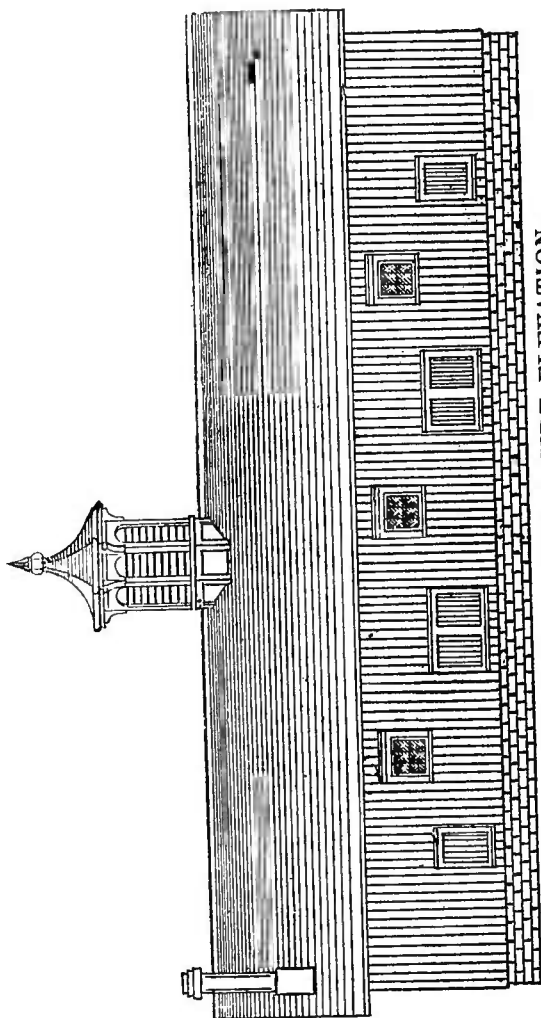

STREET & SON.—FIG. 1—SIDE ELEVATION.

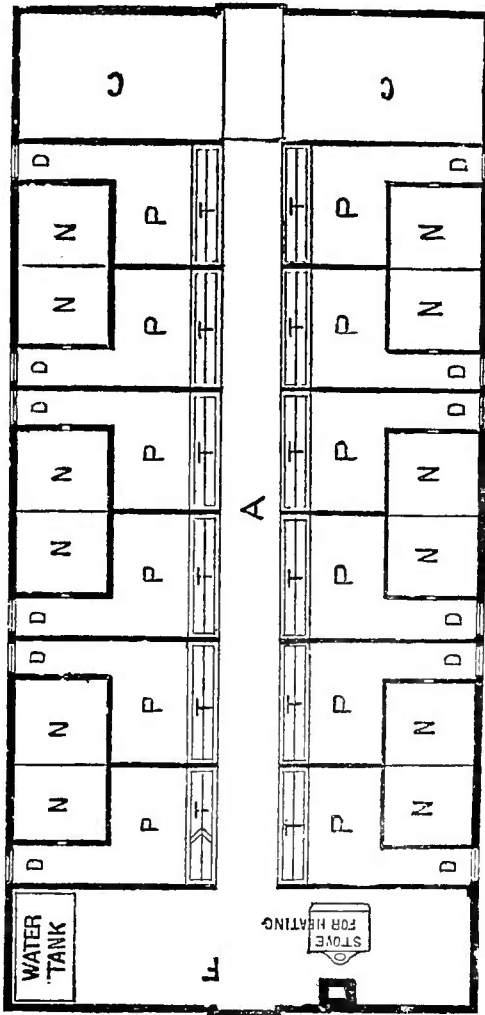

STREET & SON.—FIG. 2—INTERIOR DIVISIONS.

floor of nest is raised 2 in. above the floors of pens. The ends of nest connecting the small doors are inclosed with swinging partitions; the front is open; all other partitions are made so that they can be swung up so as to make large or small pens as the occasion may require. The small doors in pens are 2x3 ft. 6 in. The inside is lined up as high as the first girt with good tight 1-in. boards; height of girt, 4 ft.

There is a floor laid over the top of pens for the purpose of stowing bedding and for making it warmer in winter. An opening should be left in this floor directly over each nest, so that the straw can be pitted down. This floor is 7 ft. from first floor. The outside of this building is covered with stock

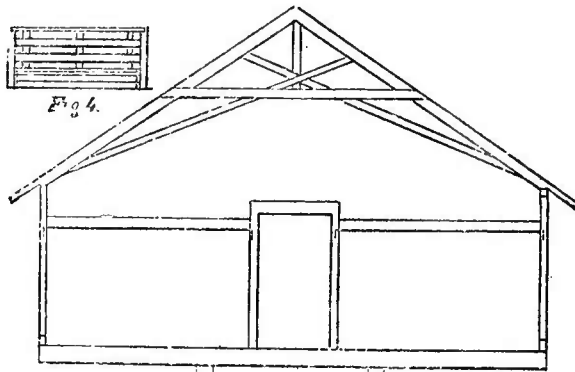

FIG. 3.—END SECTION. FIG. 4.—SWINGING GATES OVER TROUGHES.

boards 12 in. wide; battened, 2½-in. battens. The corn-crib is built in the usual manner. In the cupola there is a slide that covers the opening for ventilation, which can be opened or closed by cords from the first floor. There are two windows in the end of building that are 8x10 ft., with twelve lights. The side windows have six lights, 8x10 ft., hung with hinges.

The plans explain themselves. They embrace ground plan, elevation, and end section, showing the manner of placing the joist and staying the roof. Three pairs of rafters stayed in this manner will keep the building in proper shape; one in center and one between this and the ends. A rib should be let into the posts to take the bearing off the joist; rib to be 2x6. The height of partitions in pens is 3 ft. 6 in.

The swing partitions that hang over the trough have a latch that drops as you swing it back at any time when you want to feed, so as to keep the hogs back as you are feeding. These partitions are made open, as per sketch (see Fig. 4), of 4-in. fencing; all other partitions are made close.

Explanations of plan: *A*—alley; *C*—corn-crib; *D*—door; *F*—front hallway; *N*—sleeping places; *P*—pens; *T*—feeding troughs.

The lumber bill was as follows: 4 sills 8x8, 64 ft. long; 4 sills 8x8, 30 ft. long; 48 joists 2x8, 20 ft. long; 42 pieces for studding 4x4, 18 ft. long; 25 pieces for studding 4x4, 16 ft. long; 78 joists 2x6, 14 ft. long; 16 girts 2x6, 16 ft. long; 70 pieces for girts 2x4, 16 ft. long; 70 pieces for rafters 2x6, 20 ft. long; 6 pieces of fencing 1x6, 20 ft. long; 100 ft. of 16-ft. fencing; 4,000 ft. of 2-in. plank, 16 ft. long; 6 pieces of plank, 12 in. wide, 16 ft. long, for trough; 6 pieces of plank, 10 in. wide, 16 ft. long, for trough; 1,000 ft. of good common boards, 16 ft. long; 18 M shingles; 3,000 ft. of roof boards (culls); 2,000 ft. of common boards for floor over pens; 2,000 ft. of stock boards (dressed), 12 in. wide, 16 ft. long; 2,000 ft., lineal measure, of battens, 2½ in. wide, O. G.; 400 ft. of fencing for corn-crib; 100 pieces of 4-in. fencing, 16 ft. long.

Nails: 150 lbs. of 20d.; 300 lbs. of 10d.; 100 lbs. of 3d.; 100 lbs. of 8d.

A WISCONSIN HOG HOUSE.

The accompanying plan was designed by Prof. L. H. Adams of the Experiment Station of the Wisconsin State Agricultural College, and concerning which he writes as follows:

It will be borne in mind that this hog house is arranged especially for feeding experiments; the practical breeder and feeder can introduce such modifications as will meet his requirements. By referring to the ground plan it will be seen that the dimensions of the building are 70x24 ft. outside measurement, with 16-ft. studding. It should be placed with its greatest length east and west, with sleeping rooms

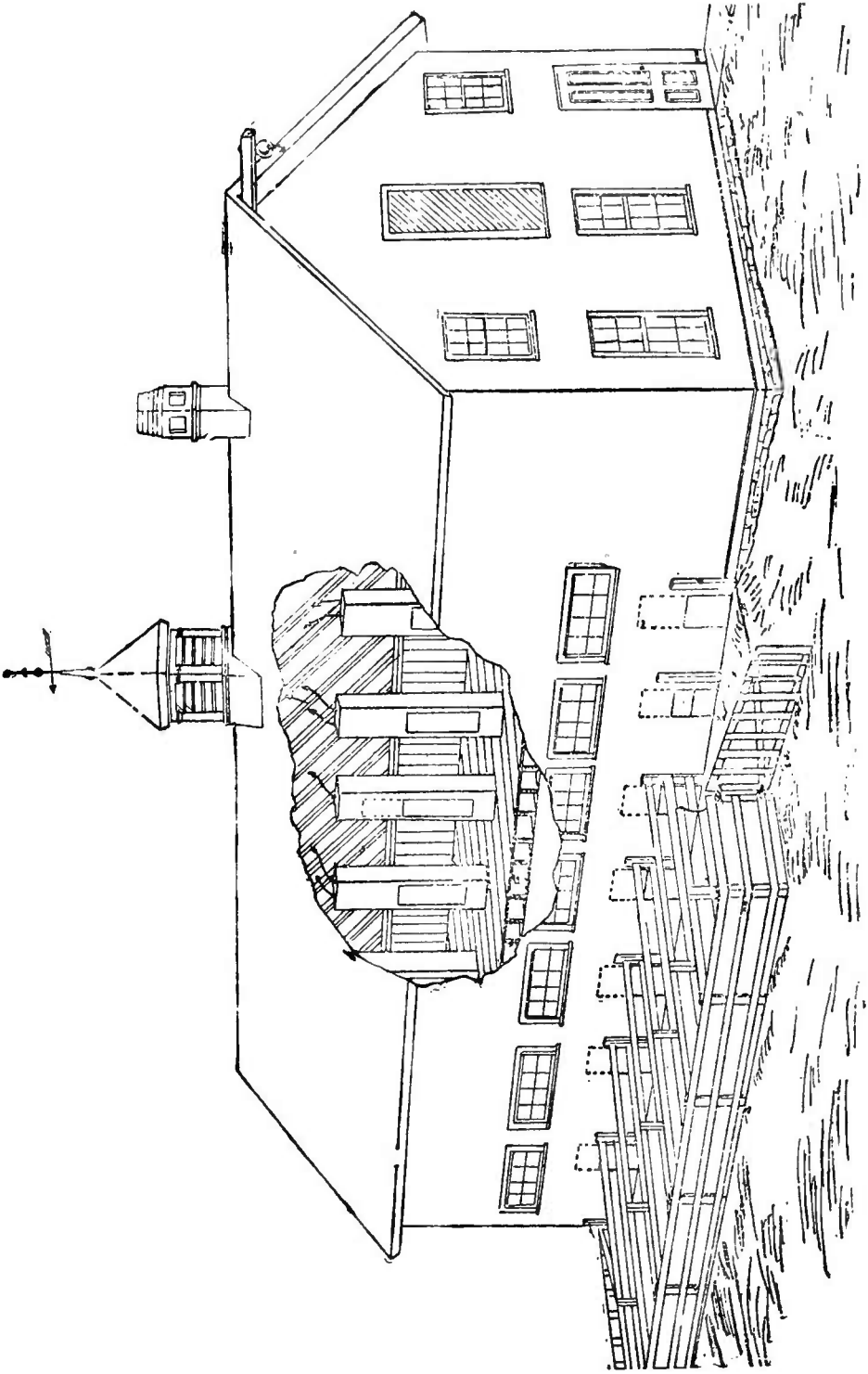

FIG. 1.—HOG HOUSE.

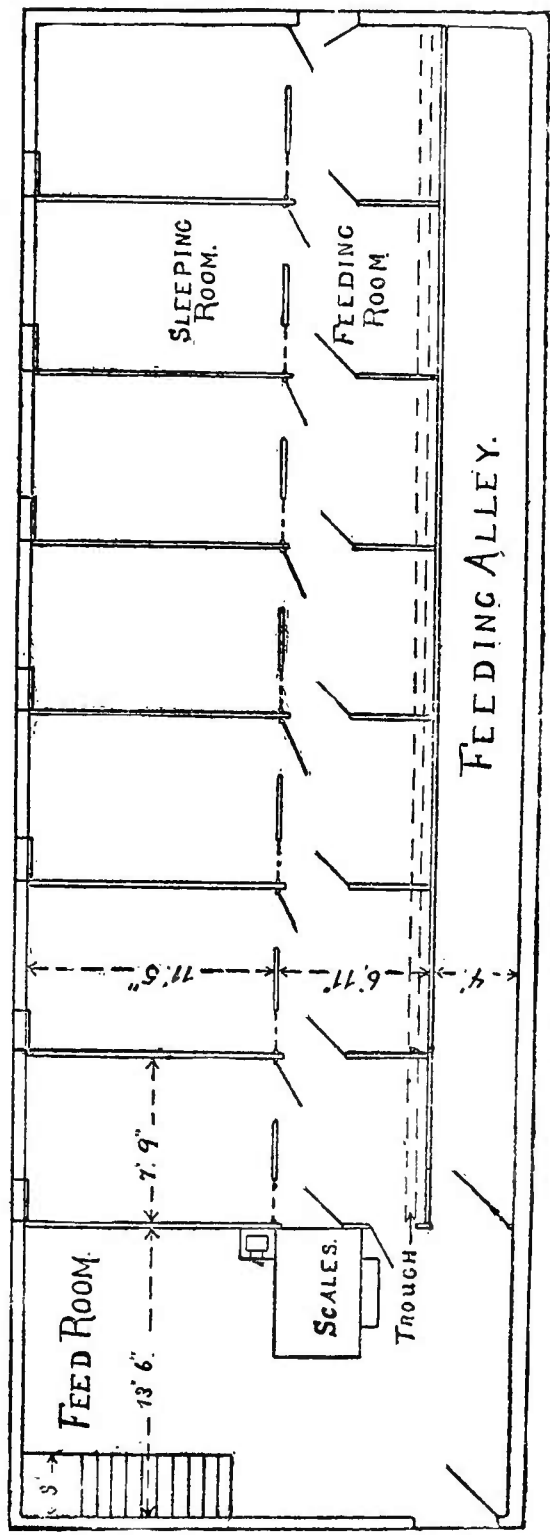

FIG. 2.—GROUND PLAN OF HOG HOUSE.

and yards on the south side for sunshine and warmth. At one end of the building a weighing and store-room is entered through a door sufficiently wide to admit a swill cart; this room is $13\frac{1}{2} \times 24$ ft., and is provided with a chimney and all the facilities for heating water, weighing hogs, etc. A feeding alley four feet wide leaves this room and extends the entire length on the north side of the building. In the plan as here given there are seven pens, each 7 ft. 9 in. wide in the clear; a tight partition reaching to the ceiling, 6 ft. 11

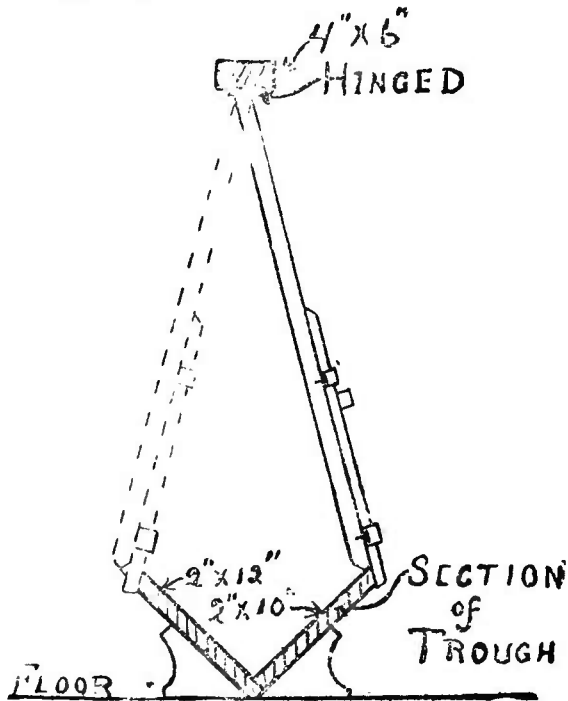

FIG. 3.—CROSS SECTION OF FEEDING LOT.

in. back from the feeding alley, divides these pens into two apartments, the feeding and sleeping rooms. This partition also serves to support the joists for the upper floor.

It will be observed that no more space is given up to the feeding rooms than is absolutely necessary, as the hogs are driven back into the sleeping rooms after each meal through small doors (designated by dotted lines in Fig. 2) that slide up and down in grooves and are operated from the feeding alley by means of ropes that run over two small pulleys screwed

into the ceiling. A large entrance to each of the sleeping rooms from the feed rooms is also provided, so that an attendant may enter any pen without disturbing the occupant of the adjoining ones. The partitions that separate the feeding rooms from each other are three feet high. A series of doors, three feet wide, through each division, afford a satisfactory means of handling the hogs, either on the scales or when loading them into wagons at the opposite end of the building.

A very convenient device for keeping the hogs back from the trough when pouring in swill (see Fig. 3) needs only to be seen to be understood and appreciated. It is a simple door hung over the center of the trough that swings and catches on either side of it by means of a wooden bar that raises up and down through iron staples. A 4x4 is sufficiently strong to support these doors; in the cut it is represented as 4x6 through mistake.

We now come to the sleeping rooms, and as these are where the hogs spend most of their time it is important that they receive careful attention. These rooms are 11 ft. 5 in. by 7 ft. 9 in. inside measurement, and occupy the south portion of the building. Each room is ventilated by means of a shaft two feet square, that reaches from the small door that is left open all the time unless the weather is very cold, so that all droppings may be deposited outside of the building; this will be done if the yard is not allowed to become clogged up with litter and filth. The outside fence of this yard is made permanent with a substantial gate hinge at each end (see Fig. 1); the division fences are made so that a ten-foot panel may be lifted out to allow a wagon to pass through and gather up the manure. It is not advisable to have these yards reach back more than sixteen feet, on account of the extra work in keeping them clean and gathering up the manure.

Mr. Theodore Louis, a prominent and successful swine-breeder of this State, has suggested that these yards be floored with plank laid in water-lime, in order to keep out vermin and reduce the loss of manure to the minimum.

Now a word about the height of the building: our farmers are coming to learn that the foundation, floor, and roof of a structure are the expensive portions, and as storage capacity is always in great demand on the farm, why build a one-story hog house when a little more outlay for boards and studding gives such a large upper room for bedding? or if not wanted for that it will be an excellent place for storing farm tools away for the winter—plows, harrows, cultivators, and those tools that are only used for a short time in the summer.

To sum up, the features of this building which we wish to emphasize are:

1. The manner of separating the feeding and sleeping rooms, which insures a clean, dry place to feed.
2. The facilities for ventilation and light.
3. The system of yards by which the sleeping rooms are kept clean and the hogs permitted to have exercise at will.
4. The details of the interior arrangement, such as the width of pens, disposition of doors, etc., may be varied to meet the requirements of the builder.

A. C. MOORE & SON'S SWINE PENS, CANTON, ILL.

The pen is 100 ft. long by 25 ft. wide and fronts the south. The illustration shows a front view. The foundation is made up of stone pillars laid up 2 ft. high and 6 ft. apart on which are placed three rows of 10x10 in. oak sills. After sills are on the foundation 2x8 oak stringers are mortised in the sills 2 ft. apart, and reach from each outside sill to the center one. A piece of oak timber is also laid lengthwise of pen under the center of these stringers, and blocked up with stone to make them more solid.

The north half of low part of pen is 3 ft. high at back and 10 ft. high at front, so that a 16-ft. rafter covers it and makes the roof about half-pitch. The high parts of pen are 15x25 ft., and are 12 ft. high at the eaves, and the roof has same pitch as the roof on the low part. These parts are used for straw above and feed-rooms and granaries below. The whole pen is floored with pine boards and covered with shingles.

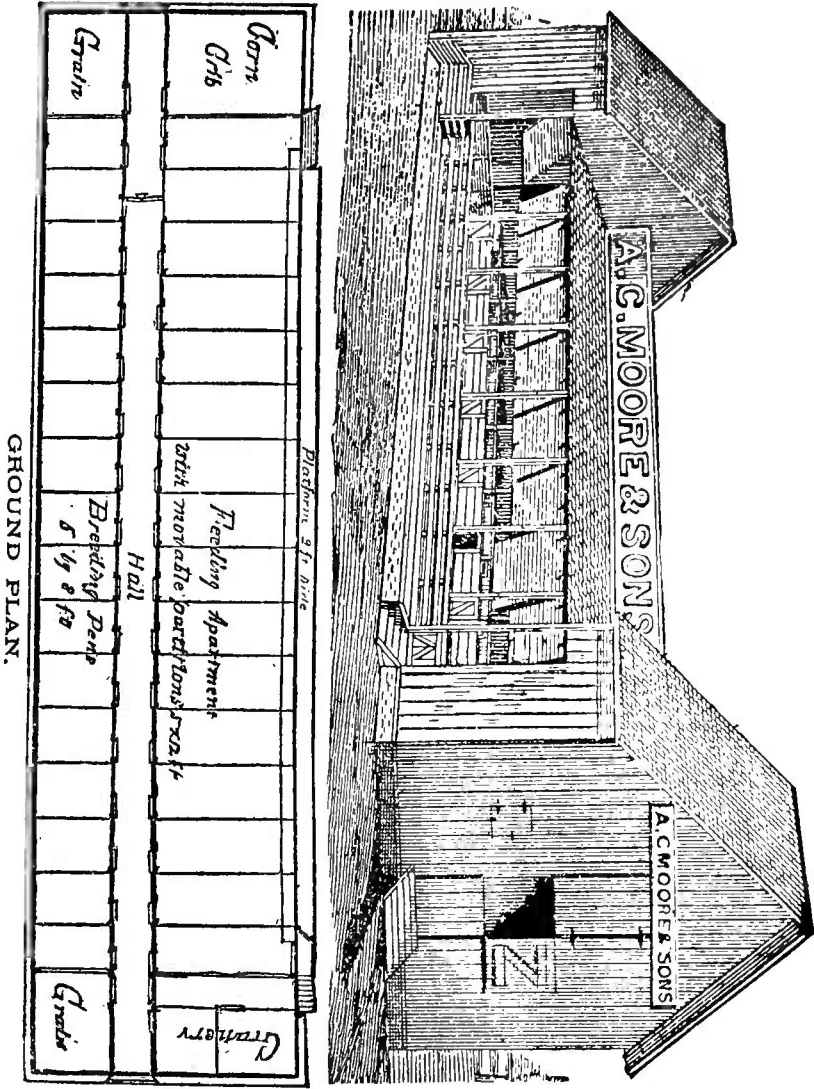

It has a hall 4 ft. wide the whole length of pen which is taken off of north half of pen. The remaining 8 ft. on low part is divided into breeding pens 5 ft. wide with a door in front part of each pen. The south partition of the hall over the middle sill is boarded up half-way, and the rest of the way is shut up by light doors, made of siding, and hung on hinges to swing in so they can be drawn back and fastened to let the sun in back pens or shut down to keep out the storm.

The floor in front of low part, which is 12x70 ft., is also divided into pens 5 ft. wide, with movable partitions and a door in the back part opposite the door in the breeding pens, and the doors are fastened together when open and form a partition for each sow separate, so she can come out on front floor to eat and keep her bedding clean and free from cobs.

We have no permanent roof over the front floor, as young pigs must have plenty of sunshine to do well.

The sows and pigs are kept in these pens till pigs are about four weeks old, when the movable partitions on front floor are taken up and all allowed to go together out on grass.

When pigs are old enough to eat soaked corn and slop the sows are kept off of this floor and the pigs allowed to go in and out as they choose, and are fed on the floor separate from the sows. Should the sun be too hot some loose boards are laid up over the floor to make a shade.

In building a hog pen we use oak lumber for foundation, studding, etc., if we can get it, as it lasts much longer; but always use a pine floor, as it does not get so slippery as oak, and pigs are less liable to strain themselves.

We build all our pens to front the south to enable us to get the full benefit of the sun on pigs in the spring by having the raised parts of pen extend across the feeding floor. We have a wind-break on three sides of it, so it makes a nice warm place for hogs to eat. The water is raised by wind power into an elevated tank so it can be run in any part of the pen.

We are now building two more pens like this one, and expect to make a greater effort next season, if possible, than ever, to supply the increasing demand for our pigs.

A NEBRASKA PIGGERY.

The following illustrations show the breeding pen of Mr. John L. Martin of Stanton Co., Neb.:

It is 200 ft. long and 20 ft. wide, the sills are 6x6, supported on brick piers, and is floored throughout with 2-in. plank, which slants from the center toward the outside walls, having a fall of two inches in ten feet. The passageway through the center of the building is 4 ft. wide and each pen is 5x8 ft. The troughs are placed across the width of the pens just inside from the passage, and a horizontal door swings in over each trough and covers the trough while the food is being put in it. To protect the young pigs from being lain on and killed by the mothers there is placed against the inside of the pens, about six inches from the floor and parallel with it, a board about five inches wide, under which the little pigs can run for protection. The outside walls are 4 ft. high and the roof has a ventilator running its whole length, with windows which can be opened and shut by cords, which are fastened to the posts in the passageway. The construction of the roof and ventilator is shown by the drawings. Each pen has a separate yard or run 5x8 ft. The two end doors are divided horizontally in the middle, so that the upper halves can be opened for ventilation. With these doors and the windows in the long ventilator, and the doors into the pens open, pure air is at all times secured by means of the cross currents, and it is always cool enough inside even on a very hot day.

This building contains pens for eighty brood sows and is separated from the cook-house at one end by the passageway into the feed-yard. The cook-house, 16x20 ft., contains a fifty-gallon Profit boiler, with a well under the house and the pump inside the building, so that water can be pumped directly into the boiler or into barrels which stand outside. The rest of the space is occupied with bins for feed. There is a horse grinder just outside this house and we grind our

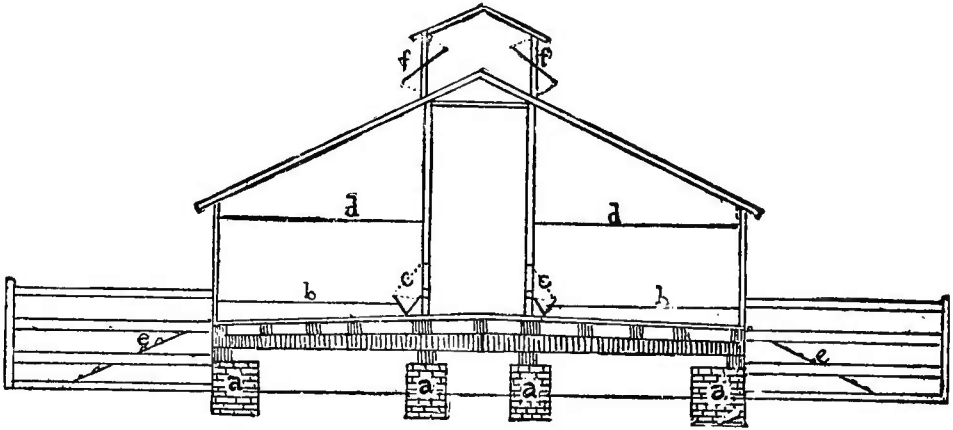

FIG. 1.—SECTION OF PIGGERY.

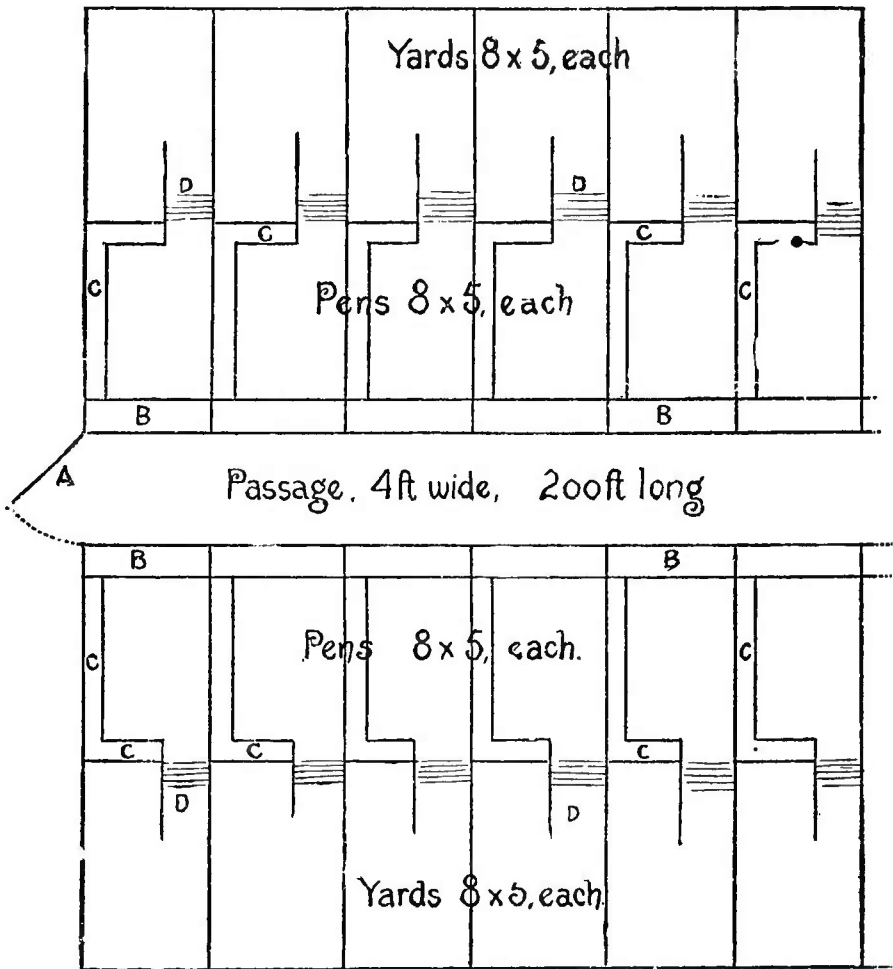

FIG. 2.—GROUND PLAN OF PIGGERY.

own feed. Mr. Martin supplements the foregoing description by the following statement of his methods:

We aim to have two crops of pigs a year—in April and October—and as we have plenty of milk we have been fairly successful in that undertaking. After weaning our young pigs we divide them, according to size, in pens having shade and a grass run and feed them milk and bran and potatoes and shorts cooked, giving less of the milk and more of the solid food as they grow older. They get a good deal of green stuff during the summer—fodder corn, the thinnings from the ruta-baga and mangel-wurzel patches and all the extra garden stuff. When they weigh about seventy-five pounds we turn them into a large pasture with shade and running water and feed them corn and green stuff. When they weigh about one hundred and fifty to two hundred pounds we turn them into the feed-lots to follow steers and when fat we ship them to Chicago.

Were we to build another piggery we would make our pens 6x8 ft. instead of 5x8 ft. With this alteration we think the building entirely satisfactory.

MICHAEL RICH'S BARN.

Mr. Michael Rich of Flanagan, Ill., has a little hog barn that has been frequently spoken of as one of the most complete things of its sort in the country, and its cost is certainly very moderate.

The peculiar feature of the windows at apex of roof is especially commended, as it serves to admit, in the early spring, the warm rays of the sun upon the north row of pens, the south row being lighted by the lower tier of windows, thus affording a sun-bath to all the occupants, the value of which in swine culture is well known.

The foundation is made of blocks of stone which are laid about four feet apart. Sill beams are of 6x8 lumber. Frame consists of 2x6 scantling placed 2 ft. apart and which are 7 ft. high. There are two rows of 4x4 posts—one on each side the alley, 6 ft. apart, extending to and supporting the roof—as

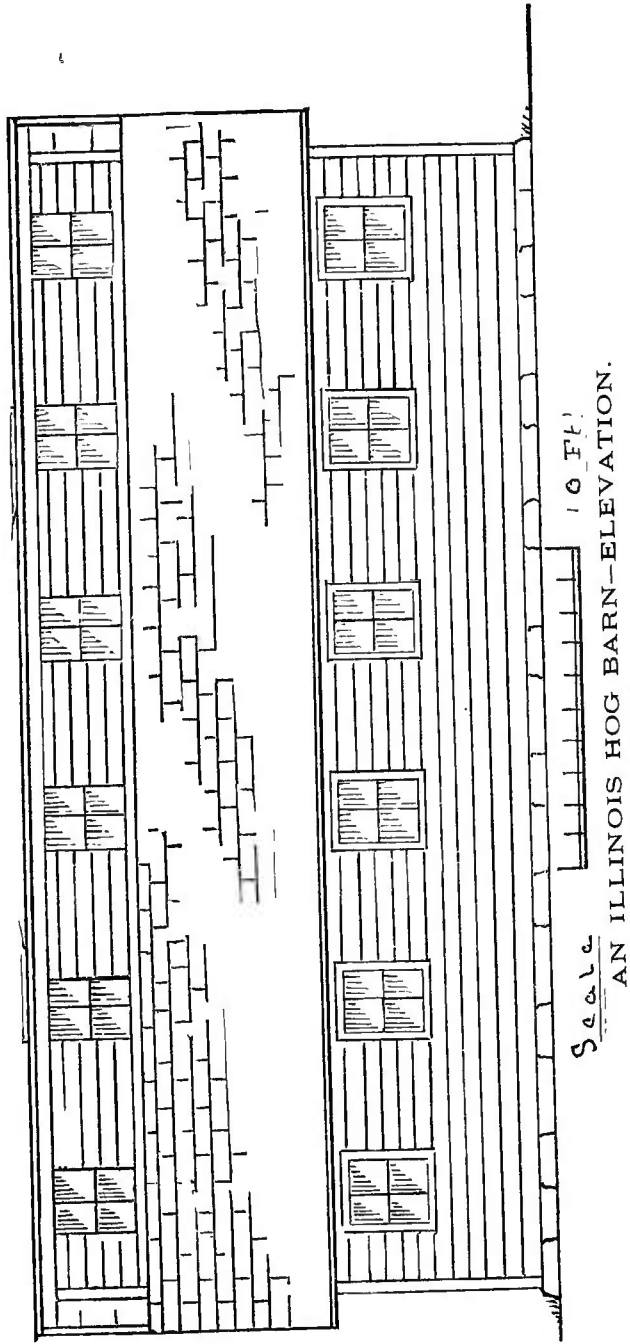

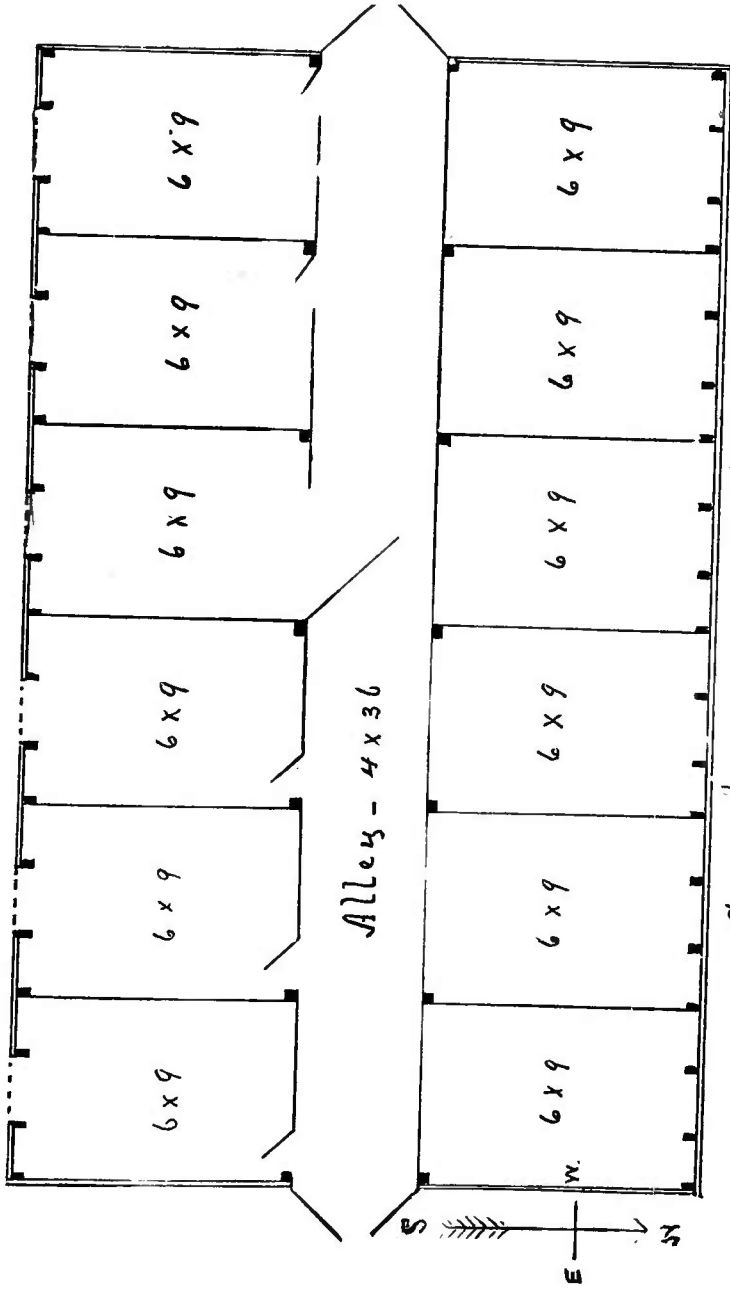

Scale 10 Ft.
AN ILLINOIS HOG BARN-GROUND PLAN.

shown in diagram. Girts of 2x6 across every 6 ft. Plate beams consist of a 2x6 and 2x4 spiked together. Rafters are 2x4 and 2 ft. 6 in. apart. Roof is one-third pitch and made of sheeting and shingles. Sides of "drop-matched" 6-in. siding. Eaves and gables project 13 in. Floor joists are 2x8 and 2 ft. apart. Floor of 2-in. plank. Windows are 2 ft. by 2 ft. 3 in. Those above are made to slide sideways and the

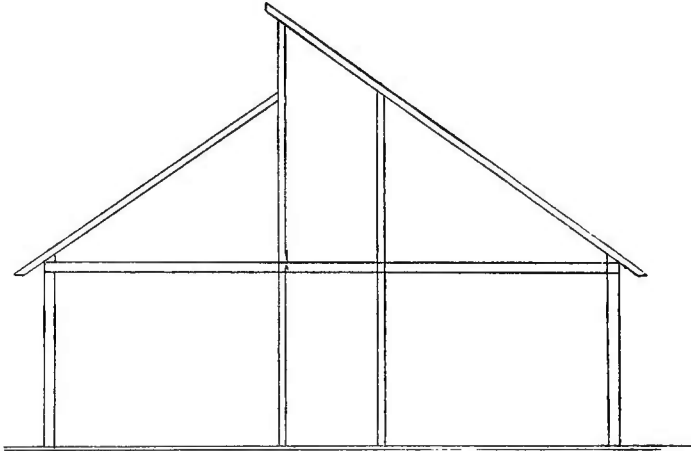

HOG BARN — FRAME.

lower ones up and down. All the partitions are movable "drop partitions" except those adjoining south side of alley, and also the middle cross partition.

Expense items were as follows: 4,400 ft. stuff lumber at \$16, \$70.40; 1,250 ft. drop siding at \$25, \$31.25; 1,500 ft. sheeting at \$14, \$21; 1,250 shingles at \$4.50, \$5.63; carpenters seven days at \$7, \$49; paint, hardware, glass, etc., \$22.72; total, \$200.

A PENNSYLVANIA SWINE PEN.

Mr. C. P. Waugh of Independence, Pa., has a hog house which is described as follows:

The ground plan shows the building 24 ft. long and 16 ft. wide, divided the long way into three parts, the middle part 4 ft. wide and the others 6 ft. each. The partition A along the north side of the middle division or alley is $3\frac{1}{2}$ ft. high.

It is made in three sections and can be raised up to the ceiling so as to make the feeding floor 10x24 ft. if desired. The posts along this partition are 4x4 inches. Heavy inch pieces are nailed on top and bottom, with a good piece of hard wood spiked on the outside of these blocks so as to allow the partition sections to slide up or down.

The troughs under this partition are also made in three sections to fit between the posts. These troughs stand about

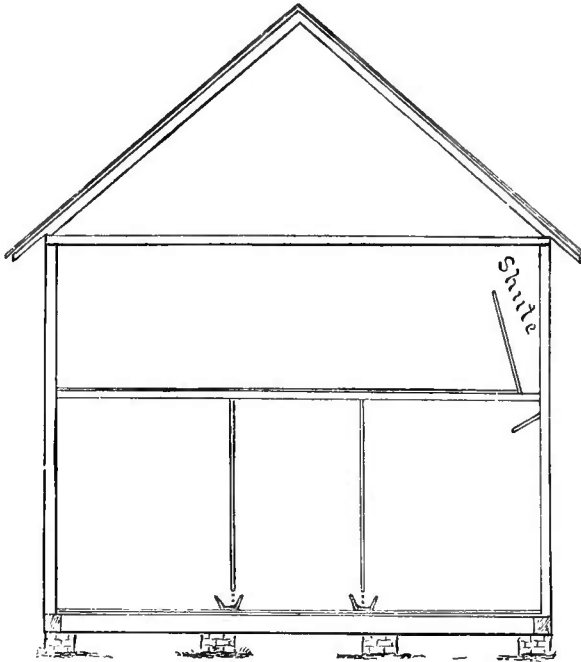

ELEVATION.

two-fifths of their width in the alley for convenience in putting in the feed. When the feeding floor is enlarged by raising the partition, as above mentioned, the troughs may be removed. The long section on the south side of alley is divided by the partitions B B into three pens for sows and pigs. These partitions are also movable, so as to throw all three pens together if desired. At C there is a slide door. When the house is not needed for sows and pigs, but is in use for fattening hogs, they pass under the stairway and through this slide door from the feeding floor to the pens for sleeping quarters. D D D are doors hung at top to swing both ways,

allowing the hogs to pass either way and at the same time keeping the chickens out. At south side are three open yards, as shown. Three windows, W W W, light the house from the south side. There should be three on the north side to correspond with these. At the west end of the feeding floor there is a door through which the manure is thrown into a pen outside. The door D on the north side and near the west end is for the passing in and out of the hogs.

The house is two stories high—the lower story 7 ft. and the upper 5 ft. to the square. It is enclosed with siding, all

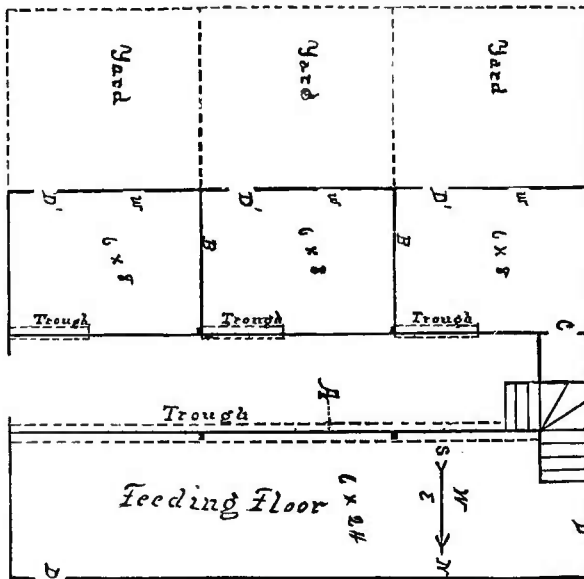

GROUND PLAN.

but the upper story on the south side. This is of slats, up and down, like a corn-crib. The upper story is for storage of corn and other feed. The roof is of shingles and the floor is of inch boards, double, with the joints broken. The lower story is lined up 3½ ft. from the floor, except in the pens for the sows; here the lining commences 8 in. from the floor. This is to keep the sows from smothering the young pigs. The elevation plan shows the east end. There should be a door in the middle below and one above. Corn thrown into the chute, which extends the length of the building, falls to

the feeding floor below. Striking the slanting board beneath it is made to scatter over the floor, thus saving much time otherwise required in carrying and scattering the corn.

A PORTABLE PEN.

The pen herewith illustrated is 8 ft. long, 6 ft. wide, 6 ft. high at the front, and 4 ft. high at the back. See Fig. 1. The front, supposed to face the south, is made of two upright corner posts of 2x4 in. stuff—each 6 ft. long—into the edges of which are let and securely nailed four 6-in. fencing boards, each 8 ft. long. If a closed front is desired five boards, or boards of greater width may be used; but we find that four, as here shown, answer very well, except in stormy weather,

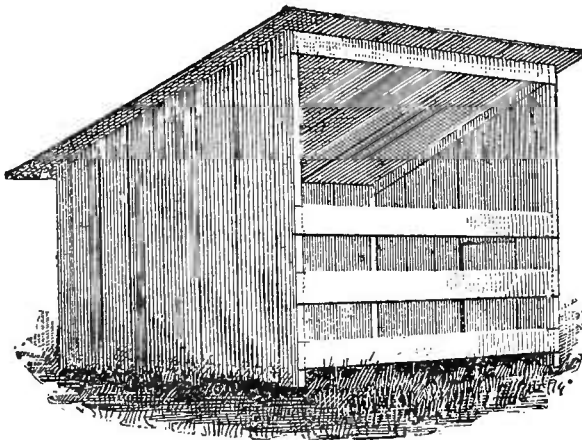

FIG. 1.

and then further protection is readily added as needed at the time.

Fig. 2 shows the inside of the north wall of the pen. It consists of two corner posts of 2x4 in. stuff, each 4 ft. long, connected at top and bottom by two 6-in. fencing boards, each 8 ft. long. These are let into and nailed to the north edges of these corner posts and then to them are nailed upright boards of inch stuff twelve inches or more in width.

Fig. 3 represents the west end of the pen as seen from the outside. It is made of wide boards nailed to two pieces of

fencing, the ends of which are made to project three inches beyond the wide boards so as to come against the inside of the corner posts of the south and north sides when these sides with the ends are set up to be fastened together.

The fastening of the corners is by means of four screw-rings at each corner, two above and two below. That is, near the top and bottom of each corner post there is a screw-ring. Those in the south posts are on the north sides of the posts, and those in the north posts are on the south sides of the posts. For these last see *a, b, c, d*, in Fig. 2. Corresponding rings are screwed into the east and west ends of the pen—see *e, f, g, h*, in Fig. 3—so that the rings at *a* and *b*, in Fig.

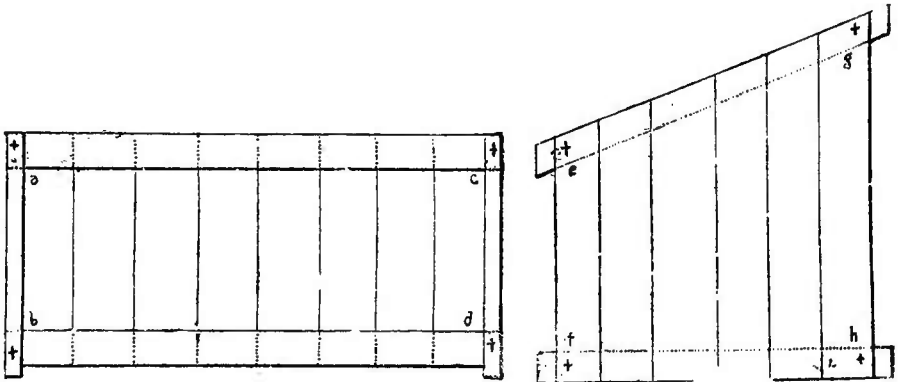

FIG. 2.

FIG. 3.

2, shall match those at *e* and *f*, in Fig. 3. A wooden pin, six inches long, dropped half its length through the rings *a*, Fig. 2, and *e*, Fig. 3, and another wooden pin through the rings *b*, in Fig. 2, and *f*, in Fig. 3, will securely fasten the north-west corner of the pen. Each of the other corners is fastened in the same way.

The roof is made of square-edge weather-boarding, batted and fastened on with hooks. For convenience in handling the roof is made in four sections, and before being exposed to the weather it should be well painted.

The position of the rings with the wooden pins through them, whereby the corners are fastened, is shown in Fig. 1, at †. †. †. †.

A MODEL HOG HOUSE.

The hog house herewith illustrated is 16 ft. wide, 20 ft. long, and 12 ft. high to the plates. The north and west sides are boarded up close, with a door in the middle of the north side. The south and east sides are boarded up close to within seven feet of the floor, the lower parts being enclosed with 6-in. fencing boards, varying from 3 to 6 in. apart, so as to admit sunshine and insure good ventilation.

The ground plan is shown in Fig. 2. There are two pens on each side of the passageway which extends through the middle from north to south. This passageway is 4 ft. wide,

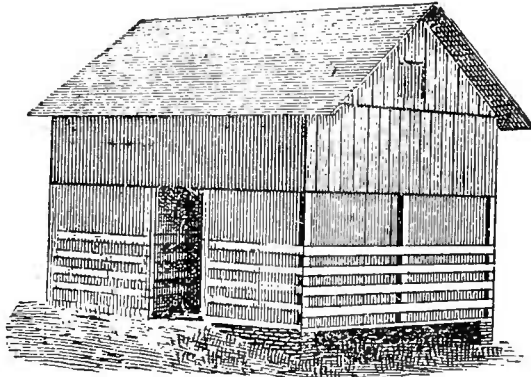

FIG. 1.—ELEVATION.

and each pen is 8 ft. square. The partitions at *a a*, Fig. 2, are movable, so that when needed two pens can be thrown together. The two partitions across the passageway at *b b* are also movable for convenience in assorting hogs or pigs. The feed-troughs are at *c c c*, and the lifting gates opening from the pens into the passageway are at *d d d d*.

The loft is used for storing feed, and is easily reached from the passageway. In each end there is a window for light and ventilation, and beneath the window in the west end there is a door through which corn or other feed is unloaded from a wagon driven along the end of the house. The entrance to the house is through the north door. The yard for the hogs is on the south side, and they pass out and in at

the south end of the passageway. They are never admitted to the north end of the passageway except when it is found convenient to bring them in through the north door or to pass them from the northeast to the northwest pen, or *vice versa*. At the east side of the northeast pen in the house from which this description is taken there is a chute for loading or unloading hogs.

A better arrangement of pens for general use and for assorting and handling stock could scarcely be devised. If only one lot of hogs is kept the partitions at *a a*, Fig. 2, and the south gates at *d d*, can be taken out, thus throwing all

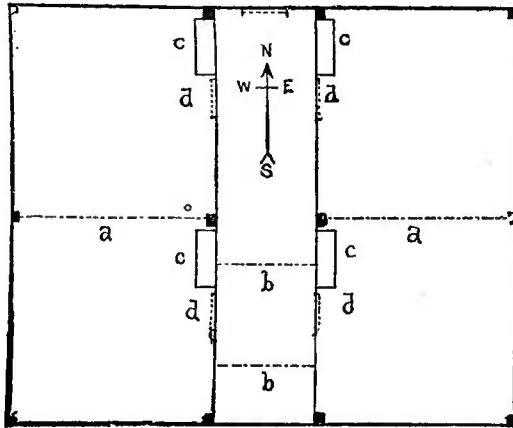

FIG. 2.—GROUND PLAN.

four pens together. Then by taking away the south partition in the passageway the hogs can have the run of the yard on the south. These pens are useful also in the weaning of young pigs and in the marking and trimming of shoats, or older hogs, as well as in ringing them.

On nearly the same plan as this house one of any greater length desired may be built. If lengthened to the north or south the slope of the roof should be changed so as to throw the water to the east and west. The width might in this case be reduced to 18 ft., making the pens 8x7 ft., instead of 8x8 ft. If preferred, the length of the building may be east and west and the slope of the roof to the north and south. By this arrangement there would be one row of pens on the south or open side, and one row on the north or closely-

boarded side. Thus a house 80 ft. long would have ten pens on the north and ten on the south side of the passageway. Those on the north could be used for brood sows in the early spring, and later those on the south could be occupied by the sows and their pigs, and from them the latter could be allowed to run in adjoining yards on the south; or the sows and pigs could all be turned into the yards together a part of the time every day if desired.

If a house of 40 ft. or more in length is built it will be convenient to have a track from end to end of the passageway on which a small truck can be run for carrying feed to the pens. It would be well also, in a house of considerable length, to use the space of one of the pens as a room for mixing feed and for keeping the fixtures that would be required in an establishment of the kind.

CHEAP AND CONVENIENT PENS.

The pens shown in the accompanying figures 1, 2, and 3 come as near answering the requisites of convenience and cheapness as any we have seen. Five pieces of oak or other durable wood 4x6 and 14 ft. long, laid on flat stones, form the foundation. On these the flooring planks, 2-in. pine 14 ft. long, are securely spiked. This floor, or platform, 14 ft. square, on which the pens are to be built, should slope a little to the north, just enough to carry off the water that falls from the roof onto the floor of the uncovered pens at the rear. The dotted lines across the ground plan (Fig. 1) show the five cross-pieces on which the floor is laid.

Pine scantling, 2x4, are used for corner posts and middle studs. The former (corner posts) are cut 3 ft. 10 in. long, placed in position, and toe-nailed to the floor. Two 2x4 scantling 14 ft. long and two 10 ft. long are then spiked on top of these, making a frame 4 ft. high, 14 ft. long, and 10 ft. wide. The middle studs are next put in and the south front run up, the studs for this being 3 ft. 8 in. high. On top of these is spiked another 2x4 scantling 14 ft. long on which to rest the south ends of the three rafters, as shown in Figs.

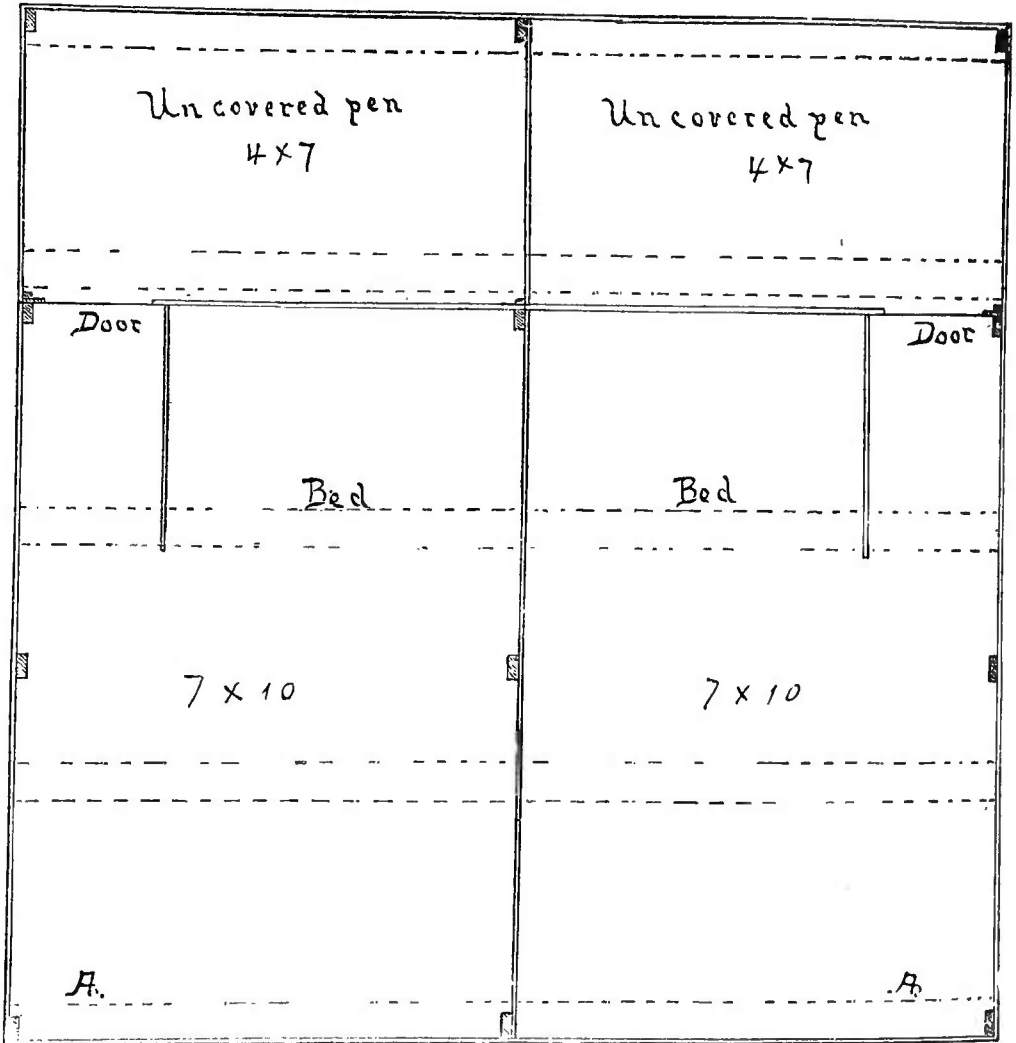

FIG. 1.—GROUND PLAN OF DOUBLE PEN, FACING SOUTH. A, A, TROUGHS.

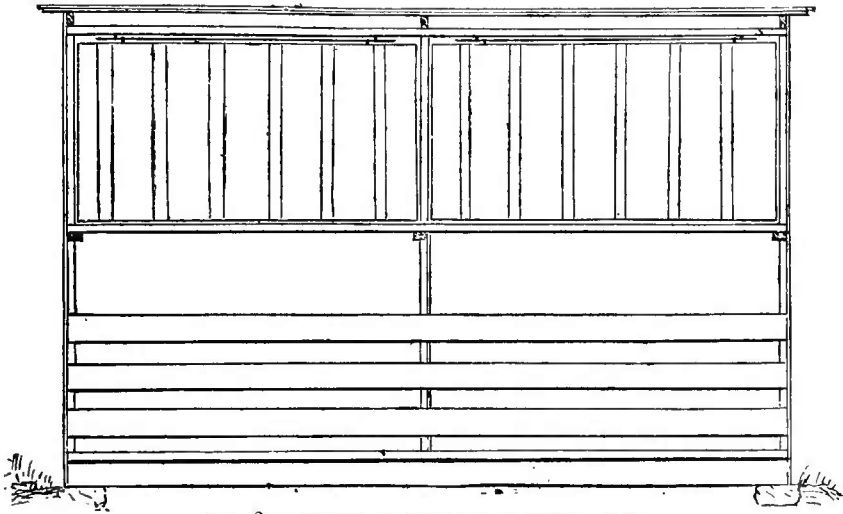

FIG. 2 — SOUTH FRONT OF DOUBLE PEN.

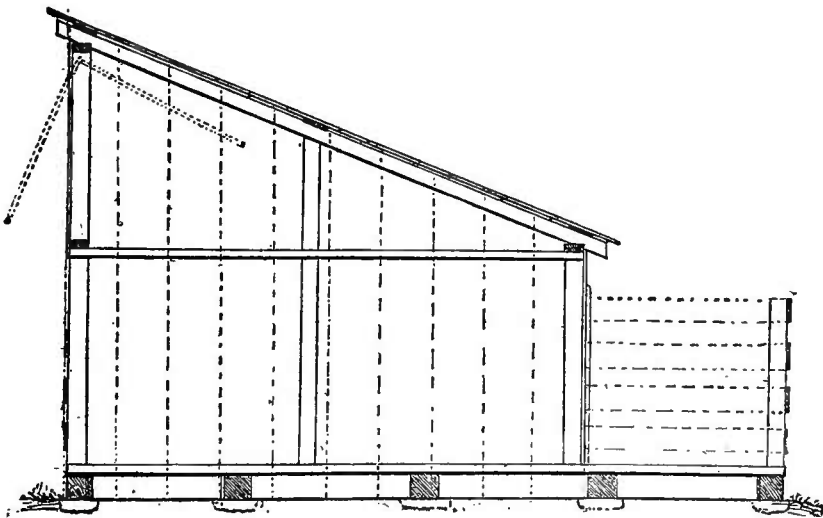

FIG. 3.—END VIEW, SHOWING UNCOVERED PEN AT REAR.

2 and 3. Across these three rafters are laid three 14-ft. fencing boards to receive the roof. The east and west ends are then boarded up close, and for winter can be battened. The upright dotted lines in Fig. 3 show how these boards reach from the rafter to the ground, being nailed to the rafter at top, the cross-piece below, and the edge of floor near the bottom. The north side is also boarded up close and the doors in this side cut out.

The roof is made of good common pine boards 12 ft. long laid 2 in. apart and the spaces covered with boards of same quality. A partition 4 ft. high through the middle from south to north divides both the covered and the uncovered parts, so that on each side there is a covered pen 7x10 and an uncovered one 4x7. The latter is intended for the manure, and if the pigs are allowed to have their own way they will be sure to leave their droppings there and never in the large or front pen. A wind-break about 3½ ft. high and of the same length extends south from the door along the bed.

Fig. 2 shows the south front with the lower part inclosed by three fencing boards; though for use in winter it should be boarded up close. The upper parts have battened doors hung so as to swing in and fasten up beneath the roof, thus admitting sunshine to the pens in winter; or they can be swung out to form an awning along the front for shade in summer. These pens can be made almost or quite frost-proof when occupied in winter by nailing inch boards to the studding around the inside and filling in the two or four-inch spaces with dry straw. The troughs are placed at *A A*, and may be of any pattern, and be reached with the feed in any way the builder may decide. Where the saving of all the manure is important the small pens at rear may have a separate roof over them; in which case they must be cleaned out regularly instead of depending on the rains to wash them out. But even without roof the manure as it is worked out on the north side should be frequently gathered up and hauled away.

The two lower boards in the outer ends of these rear pens are battened together so that they can be slipped out, thus serving as doors by which the pigs are let in or out of the

pens. As it is not best to keep pigs on board floors all the time, two yards, not shown in the ground plan, are made, one to the east and the other to the west pen. These yards may be of any desired size, only they should not extend around to the north where the manure from the floor is to be reached and taken away. We have built a pair of these pens for our stock boards and find them very convenient. They answer equally well for brood sows and also for weanlings and older pigs.

The lumber for a suite of such pens was bought in Central Illinois for \$20. In this case, however, inch boards were used for the floor and the oak cross-pieces beneath were 3x4 instead of 4x6.

A CHEAP HOG HOUSE.

What the average farmer wants most is a good warm place in which sows can have early pigs in March and April. The accompanying illustration shows a single breeding pen that

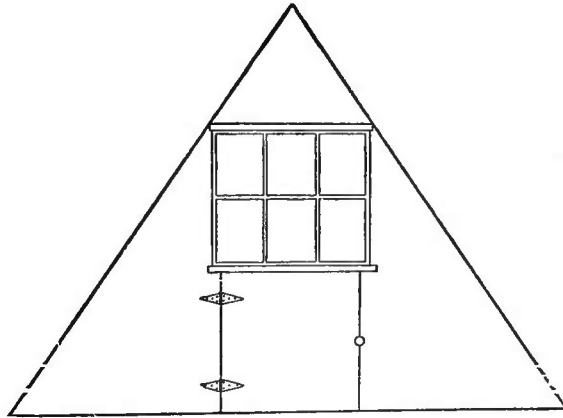

A CHEAP HOG HOUSE.

can be built for \$4. It is portable and can be made in a few minutes, and in it there is no danger of the sow lying on her pigs. The pen should be made 8 ft. long, 9 ft. wide, and 6½ ft. high at the center. Nail sides on 2x4, 8 ft. long, and then

nail on ends. Put in a door and window and strips over all cracks, and then with a little open lot on the south you have a nice cheap breeding pen.

N. COLEMAN'S PIGGERY.

From the description given by Mr. N. Coleman of Nemaha Co., Kan., of a hog-house the accompanying illustrations are made. They agree in most particulars with Mr. Coleman's plan.

Sills, 6x6; floor joists, 2x6, placed full on top of sills; front of the main building 8½ ft., rear 5 ft. Before laying the floor spike a 2x4 on the floor joists on line of the partition between alley and pens. On this at every 10 ft. set a 2x4 upright 12 ft. high. Rafters, 1x4, placed 16 in. apart. Roof, good siding, 4 in. to the weather. Let rafters rest at top against a

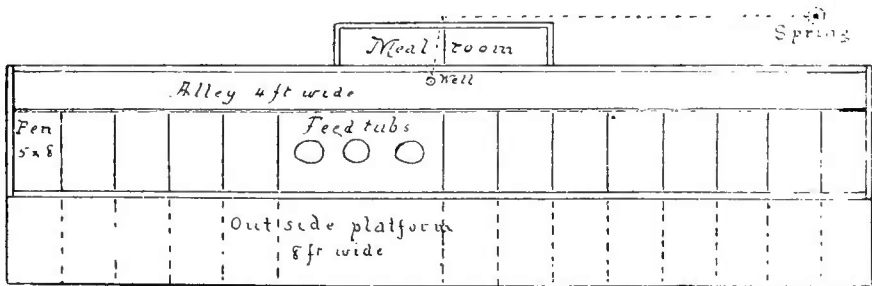

1x4 strip set on the 12-ft. upright. The long rafters at middle rest on a 2x4 as shown, and this on end of a 2x4 tie reaching to beneath the plate on which the lower ends of the short rafters rest. This tie is gained in at the middle and spiked to the 12-ft. upright. Spike 2x4 horizontally between the 2x4 uprights to form the top of partitions along alley. The dotted lines across pens in elevation show height of partitions between pens, the same as along the alley or passageway.

Place a 2x4 every 5 ft. at the rear of pens, also midway between each of the 12-ft. uprights along the alley. To these and to the 12-ft. uprights the ends of the movable partitions are to be fastened. Our experience teaches that pens 5x8 are too small for general use, and in building we should

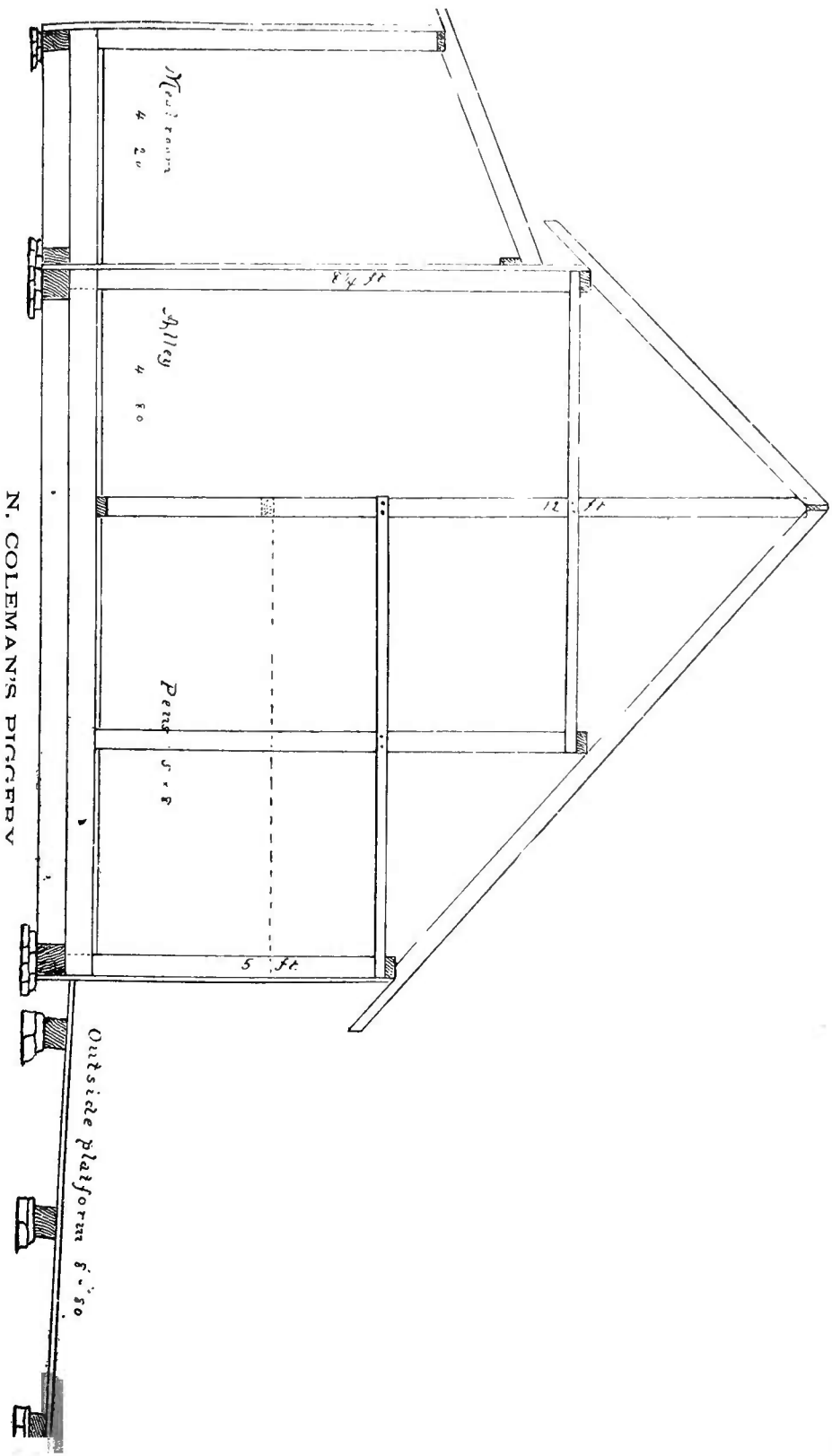

N. COLEMAN'S PIGGERY

leave most of the pens 8x10 and put in other partitions when needed. Make close partitions across the outside platform to correspond with those inside, thus giving to each sow a separate outside pen also.

The meal-room is a lean-to or offset to the front of the main house, and should be made of flooring. The building should front north or west, so as to give the pigs the benefit of the sunshine. Paint roof and all with water-lime and skim-milk. Use a wide brush and keep well stirred, as it is inclined to settle. Throw away the settlings after using as much of the mixture as will spread well.

Mr. Coleman says he gets his water from a spring 350 ft. distant and higher than the floor of the hog-house. It is brought from the spring by a three-quarter gas-pipe, and comes into the house on the plan of a syphon, with a stop-cock at the house.

A MOVABLE PIG HOUSE.

Mr. L. N. Bonham of Ohio highly recommends a movable breeding pen which he has used and concerning which he sends the following:

I have a hog house opening out onto a floor 16 ft. wide and as long as the hog house. This floor is divided into pens 10x16, and from each pen a door opens out onto a stone floor 25x40. From this the hogs can pass, by gates at each end, to blue-grass lots or have the range of a small lot. They will generally keep the floors clean and use the lot for droppings. This arrangement was made for saving manure and for convenience in handling brood sows and their litters in the early spring, and for feeding fat hogs in the fall. I find it handy, easily kept clean, and furnishing a deal of comfort to our pigs. It is arranged to keep off the north and west winds and to admit freely the sunshine from the southeast.

But with this arrangement we often have more brood sows and pigs than can be accommodated there at farrowing time. Then, too, having all the sows and pigs come to the same house for sleep and feed brings too many together for the

best sanitary conditions. When men and animals are kept herded long in close quarters disease of some kind soon appears unless there is extraordinary care to secure cleanliness and abundance of pure air and sunshine. Impressed with the importance of securing these three essentials to the highest state of health I have devised a cheap, comfortable pig house which can be set up in any lot or grove or pasture field where we may for a short time give a favorite sow or litter the attention desired. By this device I can place the sow and her young litter on land and sod that has never been defiled by the presence of others for generations past, which cannot be done about our permanent hog houses.

I have often found, too, that the sow at farrowing time is nervous and disturbed by the noise and cries of young pigs in the next pen, and she has for this reason alone often jumped up and lain down to the injury of her litter, and oftentimes the death of the choice pig follows. To save the young pigs is the breeder's first care. At least 50 per cent of the pigs farrowed in the country perish before weaning time. This loss can be cut down to 10 per cent by careful management. In the use of our portable houses I have reduced the loss to the minimum and have enjoyed the thrift and comfort secured there for our sows and pigs. I have found these movable pig houses convenient not only for sows and pigs, but handy to set in a lot to give shelter to a choice ram or boar, or even to accommodate a few fancy chickens that we have wished to separate from the rest of the flock for a season.

Provide four scantling 2x2, 12 ft. long; two scantling 2x4, 12 ft. long; 50 ft. flooring for roof, and 75 ft. flooring for sides and ends. Let the flooring for the roof be the best; free from knots and windshakes. Cut four rails, or nail ties 2x4, 6 ft. long, for the back and front (Figs. 2 and 3). Now cut siding enough for the back 3 ft. long, and then two boards 1 ft. wide, 4½ ft. long, for the front. Nail two of these boards to the flat side of two of the rails above named, letting the outer edge of each board project one inch past the ends of the rails, and have the rails flush with the ends of the boards; taking care always to put the siding square with

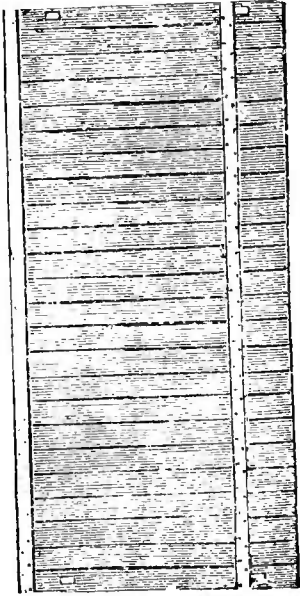

FIG. 2.

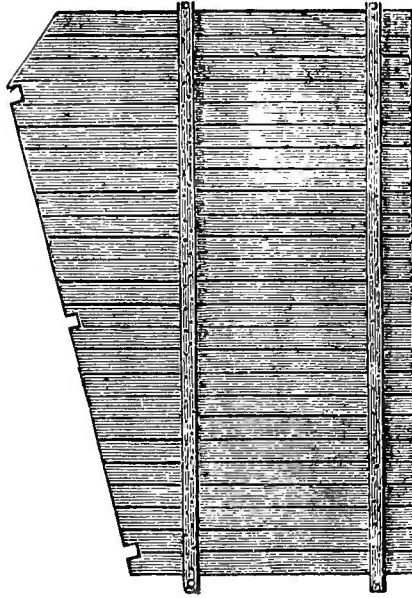

FIG. 4.

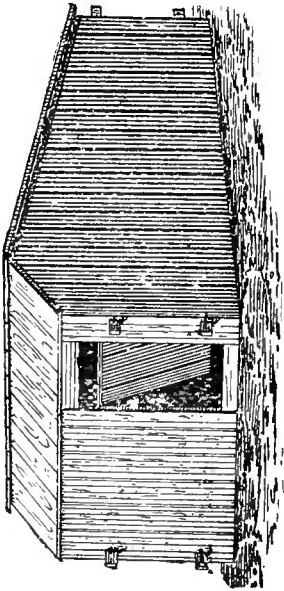

FIG. 1.

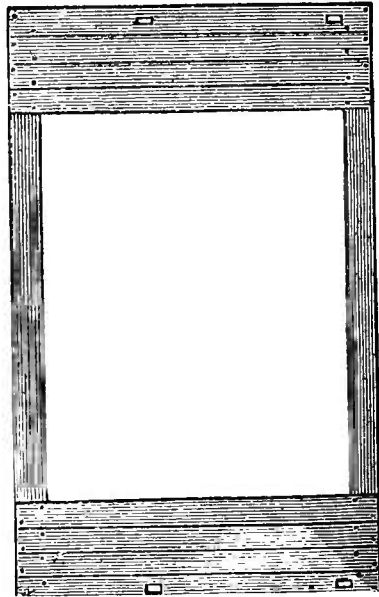

FIG. 3.

the rails. The bottom rail, on edge, keeps in the bedding, and is not too high for sow or pigs to get over easily. For the back (Fig. 2) nail the 3-ft. boards to the 2-in. face of the rails, letting the top rail be at the end of the boards, and project 1 in. at the ends of the rails, and the bottom rail be 8 in. from the other end of siding, which when set up allows the bottom rail to prevent the sow from crushing her pigs against the side.

After the siding is nailed on as above make mortises 1x2 in. just under the rails of the back and 2 in. from the edges of the boards. In the front (Fig. 3) make the bottom mortise 1x2 just above the bottom rail and the top mortises opposite those in the back. The front (Fig. 3) and the back (Fig. 2) are now complete.

Cut four rails 2x2, 5½ ft. long, and make a tenon 1x2, 3 in. long, by cutting into the rail 1 in. and ripping back to the shoulder, which makes the tenon on one side of the rail. Draw-bore these tenons with a five-eighth bit and put them into the mortises of the back and front so the outside of the rail is flush with the siding at the front and back; put in the draw-pins and the frame is complete.

Now cut the siding for the two ends (Fig. 4) and nail it to the rails as they stand and you will have no trouble in taking apart and putting up again. Draw a line from top of the front to the top of the back and saw to it for slope of the roof. This done cut three slots 2x2 for rafters to rest in, as in Fig. 4, one notch 6 in. from the front, one 3 in. from the back, and the other notch half-way between these two. Take the three rails 2x2, 6½ ft. long, that were left after cutting the four side rails, and lay in their notches so they project 3 in. at each end. Saw the roofing to project 8 in. at the rear and 3 in. in front. Lay this flooring for the roof carefully and paint each joint as laid. When done, paint the roof well. It will pay also to paint the house with oil and Prince's Brown, which is cheap and lasting. The front of this house is now open 4 ft. wide and 4 ft. high, less 8 in., the width of the rails. The closed sides should set north and west to exclude cold winds, and the open front face the east and south to admit sunshine.

We have a movable front and swinging door to close all up if a sow is to farrow there in early spring. The movable front is made by having the battens project one inch at one side, so as to catch within the siding. On the other end of the battens we have a button on each to catch the upper and lower rails. By swinging a door in the remaining space, as shown in Fig. 1, the house is closed and there is complete protection against storms. We use these movable fronts in early spring until pigs are old enough to endure the cold, when the front is taken off and laid away. If the house is set up on a dry spot where the water will not run under, or if a trench is cut behind for the drip of the roof to run off, the inmates will be more comfortable than in any of our big hog houses.

Each spring and fall we take these houses down and white-wash inside, and never have a new litter begin life in the old filth of its predecessors. With a clean house on a clean, fresh sod the young things start life without being handicapped by disease. The sow should become accustomed to the house two weeks before farrowing, and the swinging door should be kept open. The night she is to farrow it may be closed, and then the pigs are safe from any storm we ever have in this latitude.

A handy man can make two of these houses in a day, and the cost of material does not exceed \$2.50.

The above description is for a house without the skylight, shown in Fig. 1. The sash and lights cost about \$2. In bright, cold, or windy days, in March or April, the glass lets the sunshine pour into the bed, which the pigs enjoy. We cannot get too much sunshine for the pig in the spring of the year.

These movable pig houses will be found most convenient on small farms where permanent hog houses are not provided. To the tenant who wishes to give his pigs better care than the quarters of the rented farm afford they will be found of especial value, as he can move them as he does his implements and stock. To move one from one lot to another a sled may be slipped under, or the house can be taken down by removal of the pins and placed in a wagon

or carried piece by piece by one person. On flat land, where drainage is poor, it will be well to make a floor of inch boards, cut so that the pen sets down over it. This keeps the floor perfectly dry. The floor should fit the house, so that there will be no danger of a pig's foot or leg being caught between the floor and house.

In order to prevent killing the grass and destroying the sod we do not allow the house to stand long in one spot. Move often to keep the soil and grass fresh.

With clean beds, in clean houses, on clean sod, we may hope to raise healthy pigs if fed judiciously and bred for constitution rather than color and fat.

SWINE-PEN, CORN-CRIB, AND WAGON-SHED.

A combined swine-pen, corn-crib, and wagon-shed built and used by S. R. Chapin of Prophetstown, Ill., and which has proved highly satisfactory, is described by him as follows:

The main building is 28x32 ft. with a 9-ft. shed on side for wagon. The pig-pen shown on right is 6 ft. high in the clear.

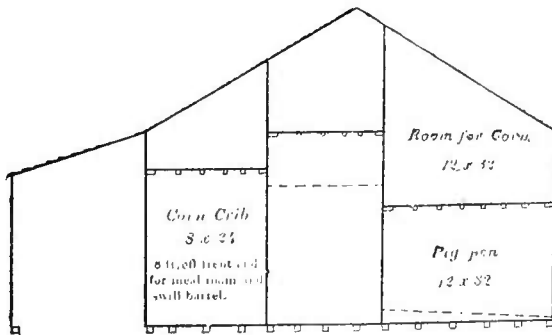

Line No. 2, top of door, 7 ft. in height. Line No. 3 is floor over driveway, 10 ft. from ground. The corn-crib on left of driveway is 8x24 ft.; 8 ft. being taken off at one end for meal-room and swill-barrel. The cost of this building was between \$225 and \$250. Our illustration shows an end section of the building.

A FROST-PROOF SWINE PEN.

A frost-proof pen is not so hard to make as many suppose. One great fault with the most of them is that they are too high. A pen 9 ft. long north and south, 7 ft. wide, 3 ft. from floor to roof at the north end and $6\frac{1}{2}$ or 7 ft. from floor to roof at south end is a comfortable and serviceable size (see Figs.

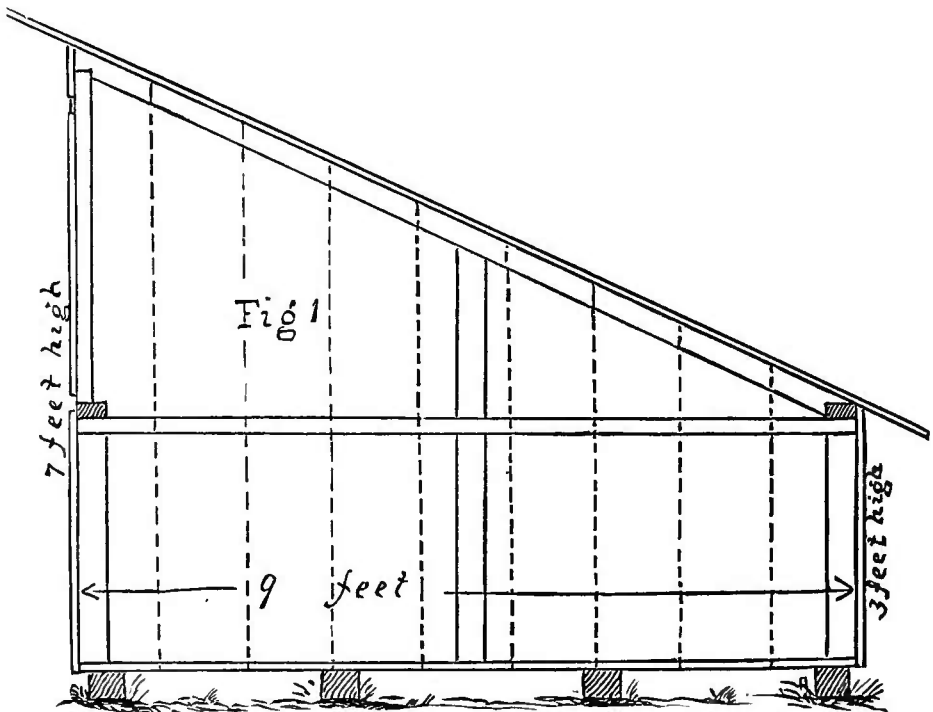

1 and 2). Buy good inch lumber 12 ft. long for the floor. Saw off the 9 ft. and this leaves 3 ft. from each piece for siding up the north end. The east and west sides are boarded up close from floor to roof. The south end is boarded up close to the height of 3 ft., the same as the north end. The upper half of the south end is closed by a hanging front that can be swung in to admit the sunshine in the winter or out as a shade from the sun in the summer.

This pen can easily be banked around with stable manure

and coarse litter up to the eaves at north end and still higher at the sides; and then if needed straw may be thrown on top in case of severe cold for a few days. Besides the pen may be lined on the insides and the spaces *A A* (see Fig. 2)

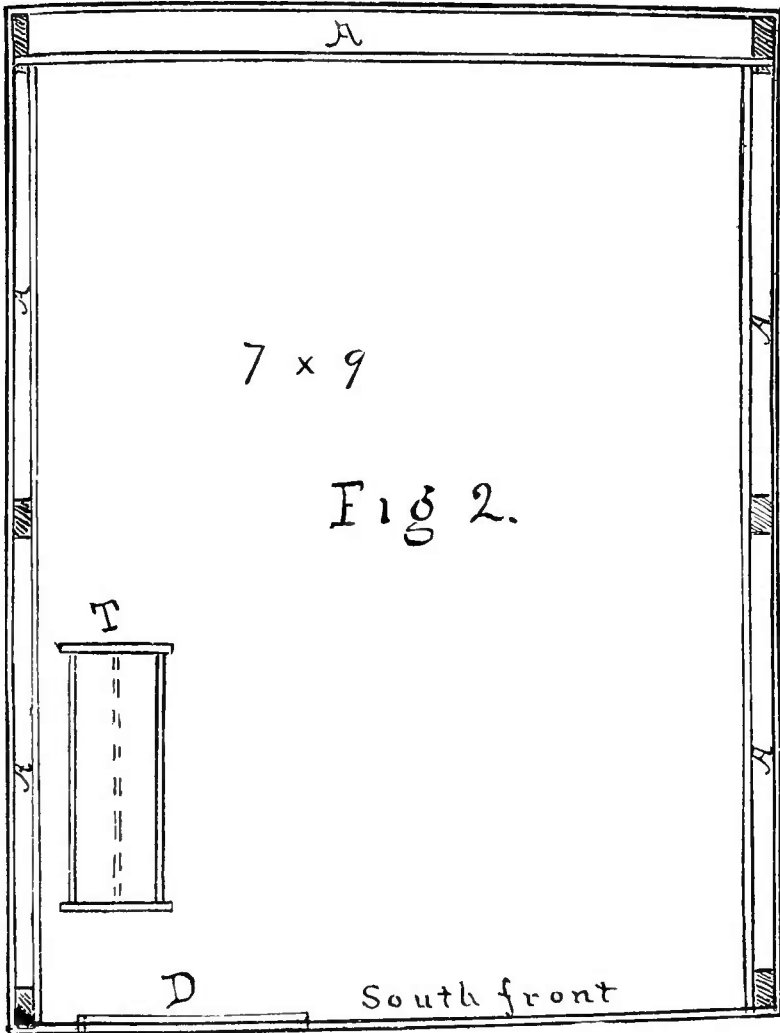

filled with straw. A door is made at *D* on the south front and a movable trough stands at *T*. The length of the roof is 12 ft. By building two such pens together, making the front 14 ft. wide instead of 7 ft., the expense of siding one end is

saved. The lumber for a double one cost us \$14. This was without the lining.

Blankets are recommended for use in protecting the sow and litter from the cold, but unless some one is at hand almost constantly they are worse than too much bedding. If they are to be used it is well to accustom the sow to be handled and blanketed for a week or more before farrowing.

WARM PENS AND HOW TO MAKE THEM.

Good shelter for the pigs during winter saves feed, helps to keep them in good growing condition and prevents an immense amount of suffering and often actual death from exposure and cold.

Ordinarily a pig pen is a terribly cold place, even when made of inch lumber and the cracks are battened. Such a pen may afford shelter from the harsh winds that whistle over the farm during the winter months, but is little protection from the silent, biting cold that sends the mercury far below zero. If inclosed on the south as well as the other sides the light and warmth of the sun during the day are shut out and the pigs suffer more than if they were in an open shed facing the south.

Without warm pens for sows that are to farrow during the latter part of the winter or early in the spring it is almost impossible to save the young pigs from being chilled to death.

A portable pen, good and warm, 12 ft. long and 7 ft. wide, may be made at a moderate cost as described below. It may be of any other dimensions preferred, or if this size it may be divided by a partition across the middle so as to have two pens, each of them 6x7 ft. The description here given is to show chiefly how the sides are made to keep out the cold.

Take two pieces of 2x4 pine scantling, each 4 ft. long. Lay them flat on the ground parallel with each other and 12 ft. apart, outside measure. On them lay four pine boards, each 12 ft. long and 1 ft. wide. Be sure that the 2x4 pieces come even with the ends of the boards and that these ends

are square, so that when the boards are nailed to the 2x4 pieces the work will be exactly square across both ends. Place a third 2x4 piece across the middle on the same side with the end pieces and nail the four boards to this also.

We now have a platform 4 ft. wide and 12 ft. long, which when set upon edge will form the north side of the pen. But before being set up saw through each of the 2x4 pieces between the two middle boards and thus cut the side into two parts, each part being 2 ft. wide and 12 ft. long. Take one of these parts, lay it on the ground, with the two 2x4 pieces

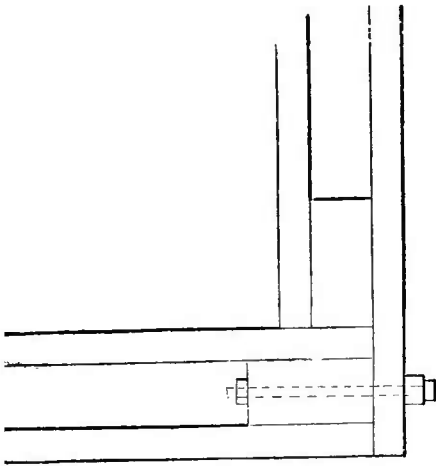

FIG. 1.

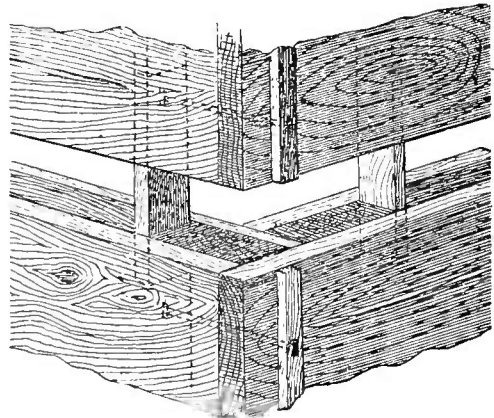

FIG. 2.

uppermost, and then nail to these two more boards, each 12 ft. long and 1 ft. wide; or, if more convenient, use narrower boards and more of them, but let their combined width be 2 ft. Do the same with the other part.

If now one of these parts is set up on edge we have a 4-in. wall 12 ft. long and 2 ft. high. Placing the other part on top the wall is made 4 ft. high. The only object in making the wall in two parts is that it may be more easily handled; otherwise it would be better if made in one piece.

The end walls are made the same as the north side, only the lower half is 3 ft. high, while the upper is 1 ft. high at its north end and 3 ft. at the south end. The south wall is also in two parts, each 3 ft. high. This gives a 2-ft. slope for the roof. In the south wall are double doors, one swing-

ing in and the other out. To one side of these, and in the upper half of the wall, a window frame and sash are fitted for light and sunshine during the day.

Fig. 1 shows how the corners are formed and how they are fastened by iron bolts. Or if these cannot be had, small ropes may be run through the holes in the 2x4 pieces, agreeing with holes in the end boards and in the upright strips on the outside. See also Fig. 2.

It will be seen that the inside boards of the ends are 8 in. shorter than the outside boards, because the latter cover the thickness of the north and south walls. The upper parts are kept in place by strips nailed to the 2x4 pieces of the upper halves, so as to reach down into the two-inch spaces of the lower halves, and there fit against the lower 2x4 pieces. Fig. 2 shows one corner before the upper and lower halves are brought close together. After the pen is set up the two-inch spaces in the walls are filled with clean, dry straw.

The pen could be made warmer and dryer by covering the inner surface of the outer wall with tar paper, well tacked down with common laths before the inside boards are nailed on. One objection to the use of straw or other filling is that it may form a harbor for vermin or for the germs of disease. To avoid this it can be renewed as often as seems necessary. Instead, however, of danger from this source, the straw, if used without the tar paper, can be the means of applying the most effectual of all disinfectants and vermin exterminators, viz., fire.

It is the practice with many poultry-keepers to use movable boxes for hens' nests, and when a nest needs renewing burn the old nest in the box in order to kill any vermin that may have gathered there. So in these portable pens. The most of the straw is taken out of the walls and burned, but enough left to make a good run of fire and smoke through them. Some care must, of course, be taken not to fire too much space at once, else the servant (fire) in this case may become the master and the pen destroyed.

The best roof we have found for a pen of this kind is made of common pine lumber laid close and then well covered with straw weighted down with poles tied across from front to back.

The floor is made of pine boards nailed to 2x4 pieces, the latter with their flat sides resting on the ground. This brings the floor so close to the ground that with a little banking up around the sides no frost will enter from beneath, and for a winter pen there will be no danger from the air not circulating under the floor. We should not use a floor of this kind for a pen that was built to remain at one place. In such a pen the floor should either have no air at all below or it should be so arranged as to allow of good ventilation when needed.

FARROWING PENS.

Mr. S. M. Shepard of the firm of Shepard & Alexander, so widely known among the swine-breeders of the United States, in an article contributed to the *Breeder's Gazette* makes some observations on the subject of farrowing pens in connection with the plan herewith given that are well worthy of a place in this volume, and from which we quote as follows:

Of all the domestic animals the sow is the only one that makes and prepares for herself a comfortable or in fact any bed for use in bringing forth her young. Other animals may and usually do separate themselves from the herd, but only the sow seeks seclusion, quiet, and comfort. A very large proportion of all animals are delivered of their young during the night, which would seem to indicate an emphasis from Nature that seclusion and quiet are important elements for successful birth. When, therefore, the sow at liberty always separates herself from her companions and goes to some remote spot and constructs for herself a comfortable bed, and if possible near a stream of water, as the time for delivery approaches, is it not an interpretation that instinct demands of her, or for her, three things, viz.: seclusion, quiet, and comfort? Following, then, the instructions thus interpreted, it is the duty of the herdsman to conform as nearly thereto as practicable. To my mind such promptings of the sow are emphatic protests against the large hog house with its mul-

tiplicity of pens and crowded condition. Observation has led the writer to avoid the use and therefore the construction of large hog houses for a number of reasons, among which are the following: first, the noise resulting from the moving about of hogs in other pens in the same building makes the farrowing sow restless, irritable, and uncomfortable. Second, it is impossible for the herdsman to go into the large house to feed or give the occupants of other pens therein special attention without creating a disturbance and commotion among the occupants, be he ever so careful. Third, if any sow in the large house accidentally steps upon the foot or otherwise injures one of her young, causing it to squeal, every sow in the house is liable to get up and become more or less excited. For several days after farrowing the sow that has undergone the ordeal should be kept as quiet as possible so that the new-born claimants for pedigrees may nurse often and accumulate strength to enable them to keep out of the way of the mother when she gets up and walks about. The noise and commotion of the other animals in the house prevent the new mother from remaining quiet; on the contrary it makes her restless, uneasy, irritable, and reckless; and the result is that the little, weak, awkward, staggering fellows are, or at least a large per cent of them, trampled under foot and either crippled or killed. Fourth, the large hog house cannot be made as warm as a small one without great expense. Fifth, the large house is more expensive than the same number of farrowing pens constructed separately. Following is an illustration of a system of small lots and the location of the sleeping and feeding pens, together with place for cribs, well, etc.

The illustration almost explains itself, and but little need be added except to give dimensions, mode of construction, etc. In size it is 250x500 ft. The widths as they center on the feeding circle are 25 ft. The dotted line is designed to show how the entire pens may be made in the form of a half-circle. If the square form is used each lot contains nearly a half-acre, Nos. 2 and 5 being a little over and the others less than a half-acre. The two larger lots can be used for the two largest litters. The feeding half-circle has a diameter

of 125 ft., and the radius is $62\frac{1}{2}$ ft. This gives room for a large crib or grain-room and for a well. *P, P, P, P, P, P*, are the sleeping pens, 6x8; *F, F, F, F, F, F*, are feeding floors, 10x12 ft.; *S, S, S, S, S, S*, are places for shade if there be no natural shade in the lots, and may be constructed as follows: "Place four forks or posts in the ground, leaving above ground three to three and one-half feet, and on these posts or forks place rails or poles, and on top of them about three feet of straw. Such a structure makes an excellent and cheap shade.

All outside fencing should be at least four feet high, and the inside partition fences need not be over three feet in

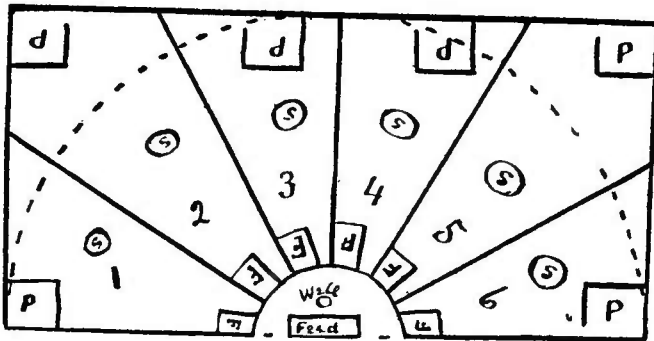

height. To construct six pens on the above plan takes 5,075 ft. of plank 1 in. thick, 6 in. wide, and 18 ft. long, or 12 ft. in length takes the same amount. If the panels are only 12 ft. long it takes 246 posts; if 18-ft. panels are made then only 164 posts will be needed. The total cost of the six pens, including sleeping pens, feeding floors, and all material, labor, etc., with lumber at \$1.50 per hundred, is \$159.50. If the lumber can be obtained at \$1 per hundred, and the owner does the work himself, the material will cost \$94.67. The advantages of the separate-lot system are many, but a few of them may be named without extending this article unduly. First, each sleeping and farrowing-room is off to itself and away from the feeding place, and the occupant of one need not be disturbed by the noise or restlessness of the occupants of the other lots; second, the pen can be made warmer and more comfortable, and if necessary, as it frequently is, can be made

quite dark; third, it is cheaper in its construction; fourth, each litter can in that way be kept by itself until weaning time, and still have plenty of room for exercise, and in addition avoid the smaller and weaker litters being robbed by the older and stronger ones. It does away with the necessity for ear marks to distinguish the members of the several litters from each other, for at weaning time the sow may be turned out and the pigs kept in the lot until they are ready for the market.

But I am digressing from the text and will return to it and try and stick closer thereto. Having prepared a pen or place, whatever its construction may be, the next thing is the bed, or material therefor. Do not attempt to make the bed for her, but give her the material and let her do that work herself. She is an artist in that line and knows better what she wants than you do. Straw or prairie grass cut up, but not too fine, is the best material to furnish her, and put it outside of the pen if the weather is pleasant and let her carry it in, as she will enjoy the work. If the weather is bad drop it down in a heap in one corner of the pen and let her arrange it to suit herself.

COLDREN & LEE'S HOG BARN.

The accompanying sketches represent the hog barn of Messrs. Coldren & Lee at Iowa City, Ia. It is partially a bank barn, being so placed against the hillside that but little filling is required to give access in front to the second floor, which is used as a granary and carriageway. Total cost about \$450.

Specifications are as follows: Foundation under main building of stone, 18 in. wide and about 2 ft. deep: sills of 6x8 in. stuff; posts 6x6x18 ft., placed as shown in diagram; floor of 1 in. lumber; floor of driveway 2 in.; floor of granary matched and dressed sides of 12 in. planed boards. Basement is 8 ft. in the clear. Roof of shingles. Posts of lean-to are 4x4x9 ft. high; posts of feeding floor, 4x4x5 ft. high with one 2x4 nail

tie; sills, 6x6, and plates 2x4. The doors between the pens are 18 in. by 3 ft. high. Outside hog doors are 3x3 ft.

It will be noticed that there is a small door indicated in second-floor plan at *A*. This opens into the feeding floor and there is a plankway by which the corn can be carried in

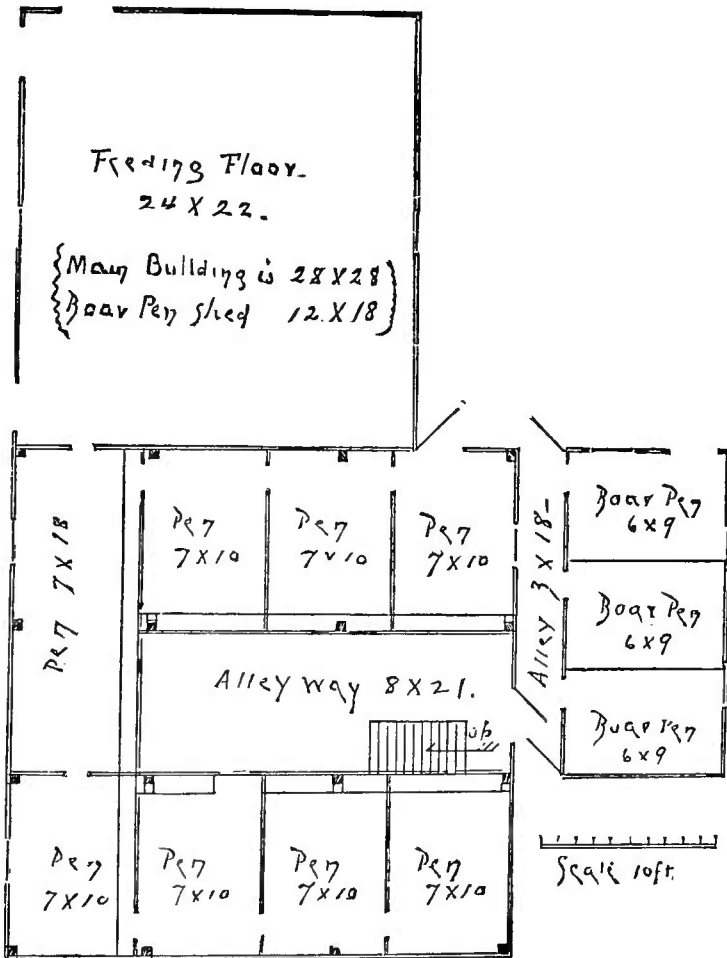

COLDREN & LEE'S HOG BARN—GROUND PLAN.

from the granary and thrown down upon the floor—making a convenient arrangement. Windows are six lights 8x8. A trap-door over stairway serves to prevent cold drafts in winter.

Estimate of cost is as follows: Foundation, 20 perch stone

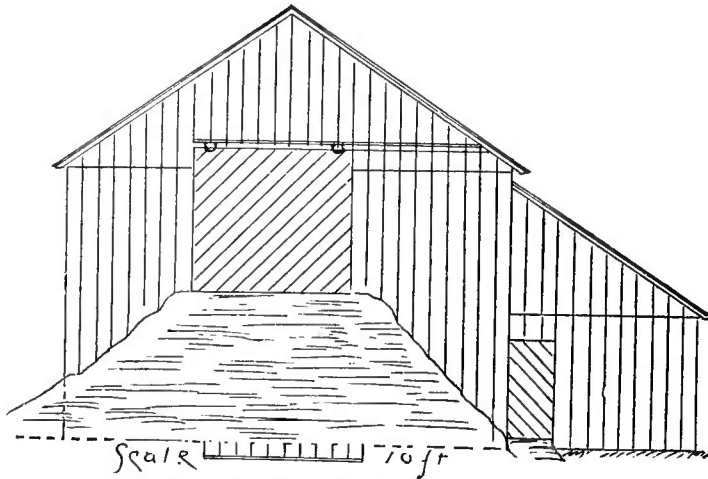

COLDREN & LEE'S HOG BARN—ELEVATION.

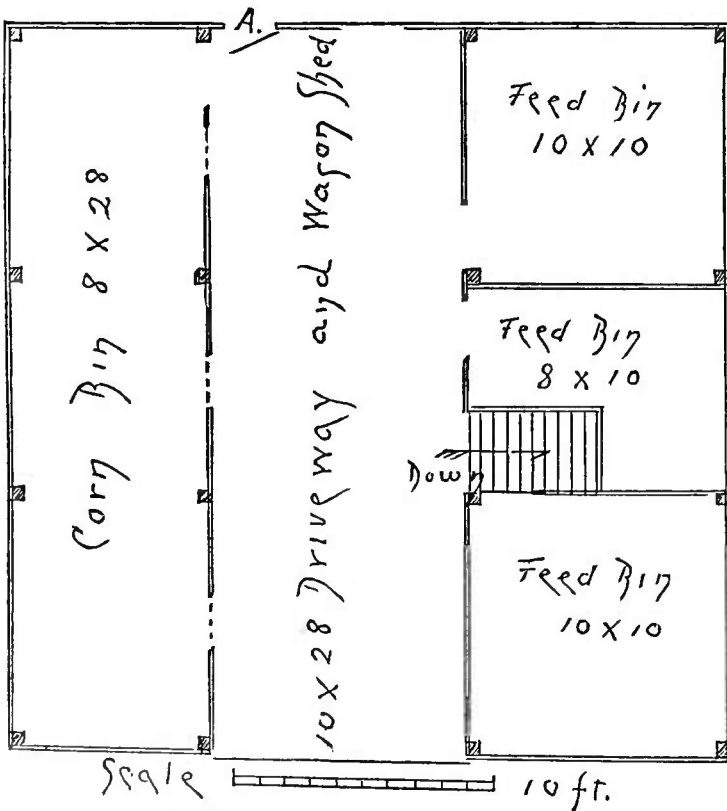

COLDREN & LEE'S HOG BARN—UPPER FLOOR.

at \$1.50, \$30; 6,000 ft. stuff lumber, frame, joists, etc., \$96; 3,500 ft. siding at \$18, \$63; 2,500 ft. flooring at \$18, \$45; 700 ft. rafters at \$16, \$11.20; 1,600 ft. sheeting at \$14, \$22.40; 16½ M shingles at \$4, \$66; paint, \$35; carpenters, \$75; hardware, say \$6.40; total, \$450.

“HANDY, WARM, AND SUBSTANTIAL.”

“Handy, warm, and substantial” are the three requisites in a plan for a hog house, and all of these will be found in the one herewith illustrated. The ground plan is shown in Fig. 1. The covered part is 14 ft. wide and 32 ft. long, though it may be longer if more pens are needed. Each of the covered pens is 8x10 and has at the back an uncovered pen with a board floor sloping from the building to carry off the manure, or at least to keep it from working back into the covered pen. The pigs will soon learn to leave their droppings in these pens and not in the bed and feeding pens.

The building should be so located that no hogs or pigs need ever have access to the outside of these uncovered pens. If in order to have this so it is necessary that the house face east instead of west, every other purpose in the plan will be as well accomplished. These uncovered pens must, however, be easy of access with a team or cart for the removal of the manure. It may be well enough for the hogs to work over the horse and cattle manure piles, but certainly not their own. The possibility of preventing this and of taking away the manure before it is tramped into the ground is considered one of the chief advantages of these pens.

A wind-break three feet long extends inward from the door at rear as a protection to the bed and to keep the bedding from working out.

The doors along the alley are 3 ft. high and 4 ft. wide. When one is thrown wide open it reaches across the alley, making it very convenient to change the pigs from pen to pen or to turn them into the open yards at the front.

If desired, instead of these open yards there may be one

large open lot or field; but it is at this side that the pigs are to pass in and out of the building.

When all the doors on both sides of the alley are closed there is a clear passageway four feet wide along which the feed is carried to the troughs. A careful examination of Fig. 1 will show plainly that the requirement of "handy" is complied with in this plan.

Fig. 2 is an enlarged drawing to show how the next requirement, "warm," is to be secured. After the building is up and the siding on—which may be up-and-down boards, tongued and grooved, or plain boards battened, as the builder may determine, other boards are nailed horizontally around on the inside to the 2x4 scantling, of which the frame is made, to the height of three feet from the floor. This forms a two-inch open space in the wall, which can be filled with straw. The wall at the back of the bed may be two inches thicker, as shown in the drawing.

Fig. 3 shows the elevation and manner of framing. The sills are 6x6. The floor joists 2x6, set on top of the sills. The floor is next laid and is of 2-inch boards, or better still two courses of inch boards, the second course laid to cover the cracks of the first.

The uprights are all of 2x4 scantling, except several 4x4 along the front, as shown. The plates and rafters are also 2x4, and so are the ties across the ends and at the top of the partitions, all of which are four feet above the floor, except the partitions along the alley which are four feet and two inches above the floor.

The uprights that support the peak of the roof rest at the foot of one of these 2x4 scantlings extending along the alley. A sash with 8x12 glass stands over the scantling along the other side, one sash opposite each pen, and set in frame so as to slide to one side to admit fresh air when needed. The roof may be made of good common boards or it may be covered with shingles.

This house can be made higher if desired and room for storage of feed overhead thus secured. If used for feeding and fattening hogs a good plank floor ten or more feet wide should be laid along the front on the ground marked in Fig.

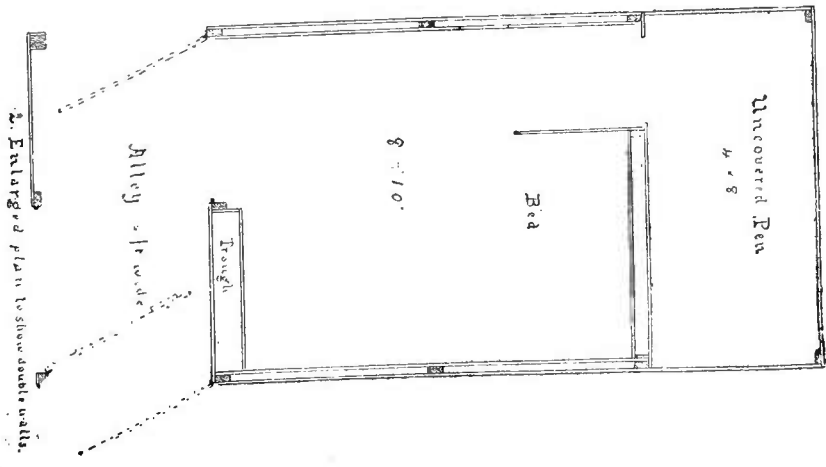
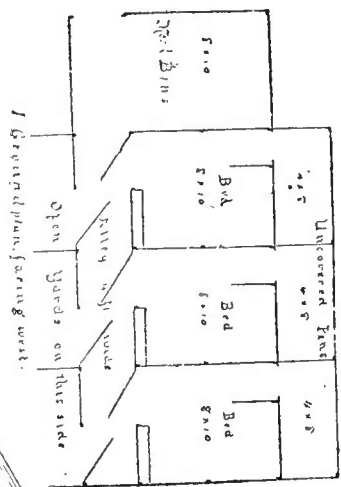
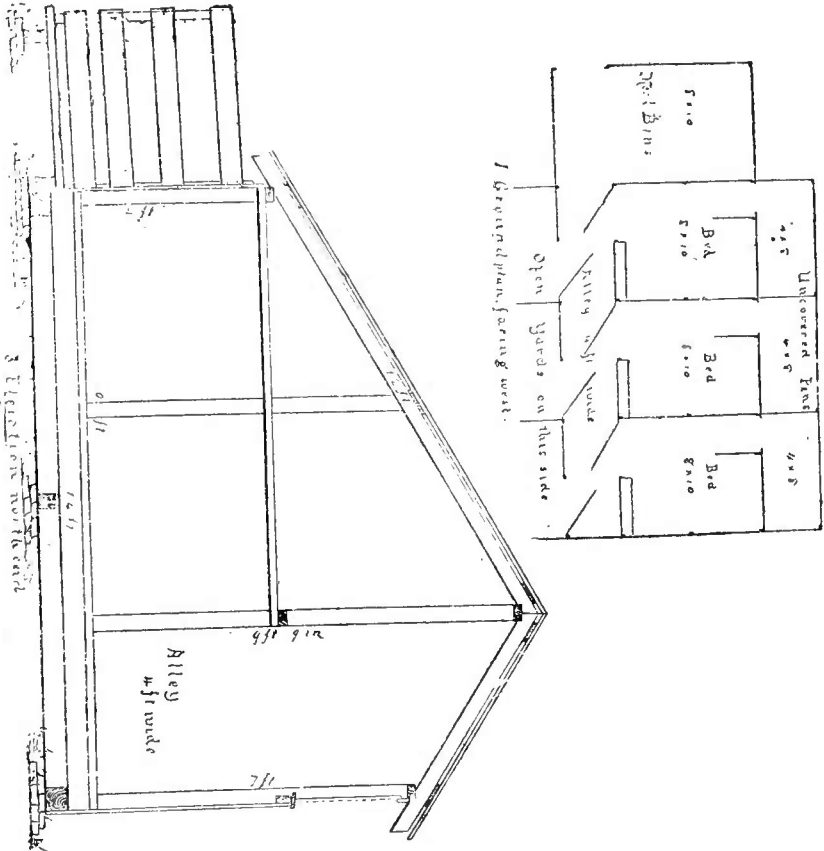

1 for open yards. On this floor the corn can be thrown, and after the hogs are done eating they are to be shut off, to their beds if at night, or to another lot if in daytime, and before they are again fed the floor should be cleaned.

The house, however, as illustrated, is designed more particularly for sows with young pigs. As a further protection against cold in severe weather a door hung by hinges at the top, to swing either way, closes the opening to the uncovered pen. The bed may be still further protected against cold by laying a few boards across, the ends resting on the cross ties four feet above the floor, and then placing straw or hay above, pushing it close under the lowest part of the roof.

BREEDING PENS FOR SOWS.

Messrs. Robertson & Williams of Exeter, Neb., have cheap and convenient breeding pens for sows, and from the description given by them the illustration herewith has been prepared, showing a cross-section of the pens. The width is 10 ft. and the entire length 64 ft., divided into twelve pens each 5 ft. 4 in. wide by 10 ft. long. The rear part is 5 ft. high and has to each pen one low door for the hogs, and above this a sliding window through which to clean out the pen. The partitions are 3 ft. high. The length of 7 ft. of each of these partitions, measuring from rear toward the front, is movable so that two or more pens may be thrown together, or even the whole length of 64 ft. used as one pen. Through the three feet of permanent partition toward the front there is a door for use in letting the hogs from one pen to another when the main partitions are in place. The sloping front is made of narrow doors swung at their middles so as to open for letting in the sunshine when needed.

In making the drawing to show the plan of these pens we have endeavored to show also the manner of framing. The floor should be of good 2-in. boards and should be laid first. On it should then be built the frame, made of 2x4 scantling. The siding should be boards, up and down, and the roof may be of either boards or shingles.

Every close pen of this kind should have at the rear another pen about four feet wide with a board floor, where the hogs will soon learn to leave their droppings and thus keep their sleeping and feeding apartments dry and clean. Besides this outside pen with a floor we have found it best

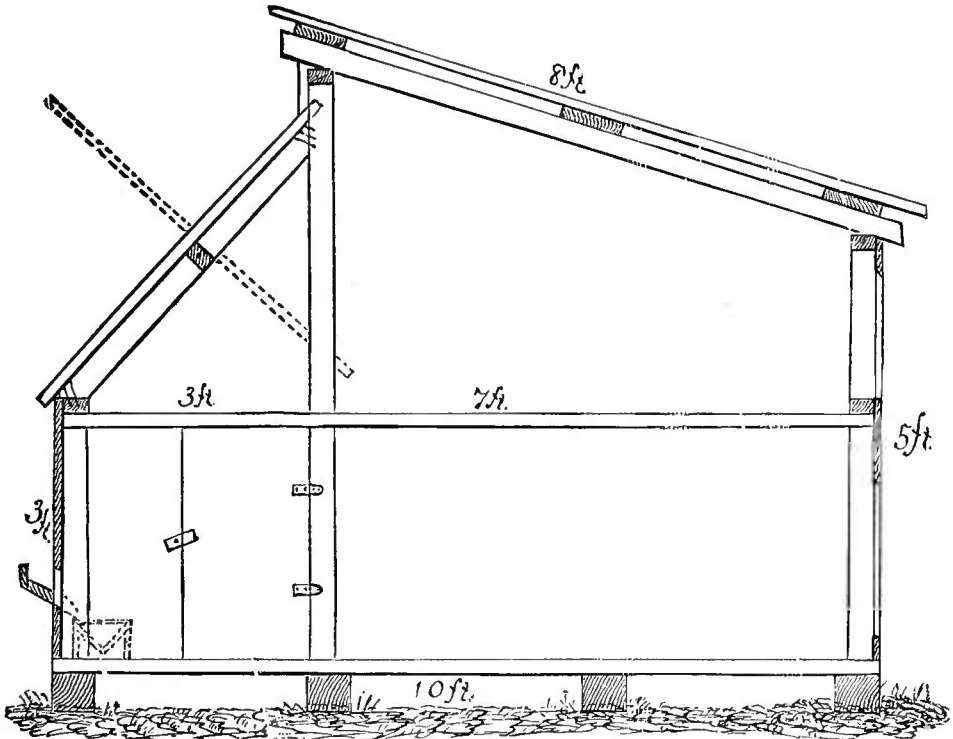

to have also a larger pen or yard adjoining in which the hogs may exercise, or at least be allowed a change from hard board floors to soft earth. This larger pen does not dispense with the smaller one with a board floor for the droppings, as the object of the floor is to make it possible to clean away the manure made without its being tramped into the ground. The hogs are therefore kept in the floored pens the most of the time, or else given so large a range in field or pasture as to prevent the accumulation of manure in the pens.

SERVICE PEN AND BOX FOR BOAR.

Mr. S. M. Shepard of the firm of Shepard & Alexander also sends us the following sensible suggestions about a service pen for boars:

His home should be a lot of not less than one acre and surrounded by a good strong high fence that will keep him in and all other stock out. The surface of this lot should be rolling enough to make it dry and rich enough to grow a good coat of grass. Inside the lot there should be a comfortable sleeping pen, a feeding floor, a chute for currying and washing him, a small pen for a service pen, good shade and plenty of pure water, either naturally or artificially supplied. The sleeping pen should be 8 ft. long, 6 ft. wide and 4 ft. high at its lowest point. Such a pen made of tongue and grooved pine flooring will cost for the lumber not to exceed \$4—including the roof of same material, and the expense of making, say \$2 more. The floor is best made of coarse sand six to eight inches deep, but if sand is not easily obtained then use the same amount of clay well hammered down, or use oak boards. At the end of the sleeping pen in which the door is placed construct an open floored pen 6x10 ft. for a feeding place, having a door 2x3 ft. opening out into the lot. At this outer door construct a chute 6 ft. long, 2 ft. wide, and 3 ft. high and floored, with a sliding door at each end. This chute is to let him in to wash, curry, and brush him, the side and top slats being placed wide enough apart to admit of easy access to the animal. The service pen should be 12 ft. square, surrounded by a good strong fence and containing two doors, one of which should open out into the boar's lot and the other into the lot or lane where the sows can be brought in. The service pen should have for a floor six inches of coarse gravel, or good strong boards, to prevent its becoming muddy. If more than one boar is kept the service pen can be so situated between the pens occupied by the boars as to be used by each.

Inside the service pen there should be placed a good, sub-

stantial breeding-box. It may be constructed cheaply of rough material, but it should be made convenient and practical. I have prepared a plan of one which I think fills all the requirements of such a box and present herewith an illustration of the same, together with a description of its construction and use. First a word or two as to its value. In serving sows with a large boar unless the sow is in some manner protected there is great danger of injuring her by

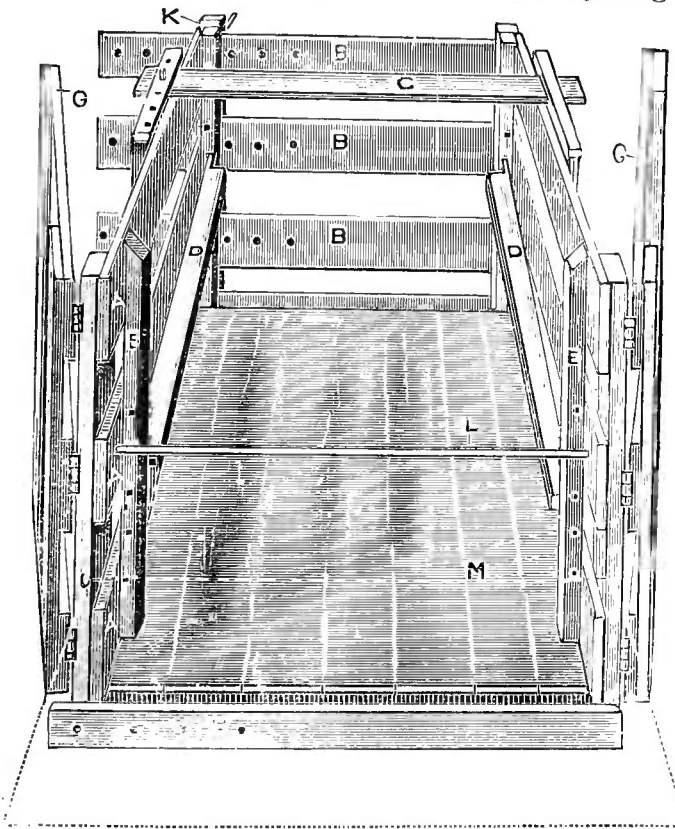

reason of the great weight of the boar, and when large sows are to be served by a young or small boar there is equal danger of injury to the boar. The sow, unless confined during copulation, is apt to move about and the efforts of the young or small boar to retain his position are not only difficult and exhausting for him but often subject him to strain in back or hind legs that injures him permanently. The breed-

ing-box obviates all the difficulties, and by relieving the immense strain upon sow and boar makes conception much more certain. The boar soon learns the use of the box, and when he becomes accustomed to it there is little trouble in securing good service.

The cut here shown is a perspective view of the box from the rear end. The box should be 6 ft. long, 2 ft. 7 in. high, 24 in. wide in its widest and 15 in. in its narrowest capacity. The right side is made stationary and the left movable. At each end of the floor there is a slot in which the posts of the extreme ends of the movable sides work, and are secured by a pin passing through the slat, *F*, and into the post. The front slats, *B*, *B*, *B*, contain holes through which pins are passed at the front end of the box so as to accommodate and secure the front end when the side is moved in or out in narrowing or widening the box. These front slats work through slots in the front posts. *E*, *E*, are 2x4 posts placed on each side near the rear end of the box, and slant backward at the top; the lower ends being two inches farther in than the tops. In these posts and the two front ones are mortised several holes one inch square, in which work the ends of the bars, *D*, *D*. The bars, *D*, *D*, are 2x4-in. scantling, and at each end thereof they are cut down to inch square tenons, which pass into the mortises in the posts as indicated, and form the foot-rests for the boar when serving. The board, *C*, a movable slide which is placed across the top of the box and forms a head support for the boar. It is 1 in. thick and 12 in. wide. At *K* the front pins are shown. *L* is a bar that passes behind the rear posts and across the box to hold the sow in the box during service. *G*, *G*, are wings which are attached to the rear ends of the box by hinges and when not in use fold back against the sides of the box out of the way. When the box is to be used they are swung around and perform the office of a chute so as to run the sow into the box easily and prevent the boar running around to the side of the box. They in that way keep him at the business end of the box. The white lines at the rear end of the box are designed to show a rear platform upon which to elevate small boars when large sows are to be served. Hooks are attached

to the rear posts at intervals of every two inches, and a bar runs under the platform and is placed in the hooks for a rest; the platform extends beyond the rests forward until it touches the sow above the hocks. On top of this platform small cleats should be nailed to prevent the boar slipping, and when he is once "up" the rear of the platform should be raised up so as to make it level and easy standing for him. In using large boars the platform should be removed. When a small sow is to be bred to a large boar the box should be drawn in to its narrowest capacity, and in order that the sow should be raised high enough and at the same time held back to the rear of the box, a movable floor and front piece must be put in. This addition should be constructed as follows: Take a board 1 in. thick, 4 ft. long and 14 in. wide, nail on the under side of each end a piece of 2x4 in. scantling and at the front end of the board attach by hinges another board 3 ft. long, 12 in. wide, and 1 in. thick. Place these two boards inside the large box and raise the loose end of the 3-ft. board and secure it 2 ft. from the front end of the box by passing in front of it a bar which also passes through holes in the top slats of the side of the box, by which there is constructed inside the large one a small box that holds the small sow back to the rear of the breeding-box. A like result can be reached by raising the breeding-box off of the floor of the service-pen and moving the adjustable side of the box into its narrowest limit and placing 2 ft. from the front end of the box a wide board in an upright position and braced by placing short braces between such board and the front end, or by securing the upright board in position by bars passing on each side of the board and through holes in the side slats bottom and top. There may be a number of such holes an inch or two apart, and thus the distance can be easily regulated to correspond with the length of the sow. The object to be secured by either of the above methods is to hold the sow back to the rear of the box so that the hind feet of the boar during service shall be outside the box.

When a sow is to be bred be sure she is ready, and if there be any doubt an easy and almost certain test is to press heavily upon the loin of the sow with the hand. If she

stands still and works her ears she is ripe, but if she move while the pressure is applied she is not ready. When ready turn her into the service pen, pull out the rear bar *L*, swing the wings around nearly in line with the sides of the box and drive her in and secure her there by passing the bar *L* behind her; then adjust the side of the box so that the bars *D, D*, will touch her sides, the forward portion of the bars coming to within 4 or 5 in. of the top of her shoulders and the rear just above the flanks, and see that she is back against the rear bar and secured there by the wide board in front. Then slide the head-rest *C* to a point just over her shoulders. Now let in the boar and keep the wings extended so as to prevent his approach except squarely behind the sow. If he is accustomed to the use of the box he will commence business promptly if in good condition, and if it is a new experience he will soon "catch on." Let him serve her but once and then turn him out into his lot, close the door of the service pen and let the sow remain for an hour or two and then put her in a quiet place by herself until the period of heat has passed.

DEVICE FOR SECURING WARMTH, SUNLIGHT AND EXERCISE.

Very few pens that we have seen combine to a greater degree the qualities mentioned in the above caption than a breeding pen a plan of which has been sent us from Edgar, Neb., and which has been used for several years by a prominent breeder of that county.

The drawing explains itself; *A, A, A, A, A*, are grain bins, 12x12, the whole 60 ft. in length. The pens are attached to the south side of this. *B, B, B, B, B*, being "bunks" 6x8, with a permanent cover reaching half-way down the incline with a battened door on hinges attached, which, when closed down completes the roof, as shown on the right of cut. *1, 2, 3, 4*, and *5*, are open pens connected with the "bunks."

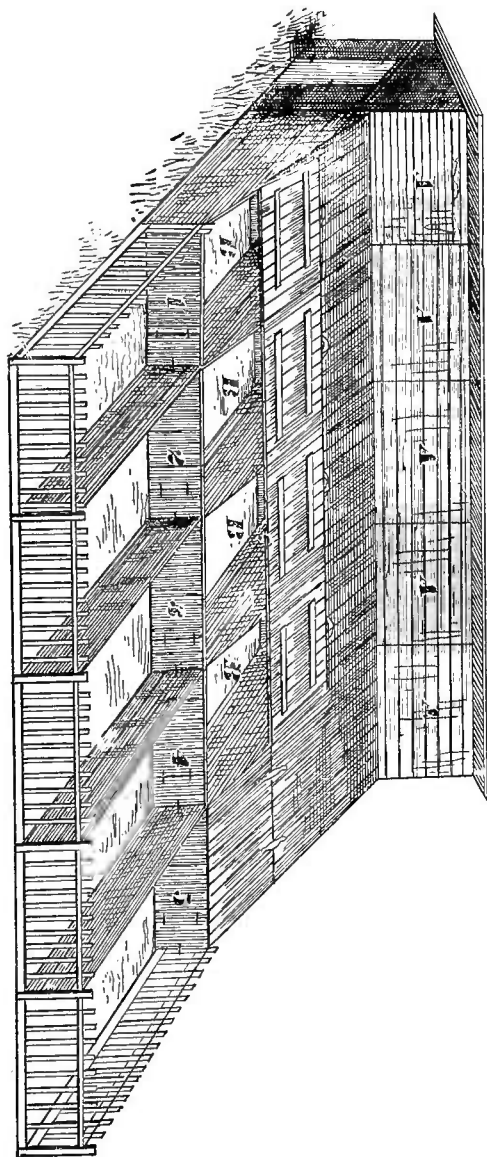

A MOVABLE TROUGH FOR USE IN STYES.

The trough herewith illustrated, Fig. 1, can be lifted from its place in the side of the stye when it needs cleaning. It is best if made of oak or other hard wood, although pine is more easily worked and will last a long time.

The side of the trough, *a*, within the stye, is a 7-in. board and 1 in. in thickness; the other side, *b*, is a 6-in. board. The two are nailed together as an eaves-trough, with a straight piece, *c*, about 12 in. long, across each end.

Along the upper side of the board, *b*, is another 6-in. board, *d*, which is held in place by a batten, *e*, at each end. If more

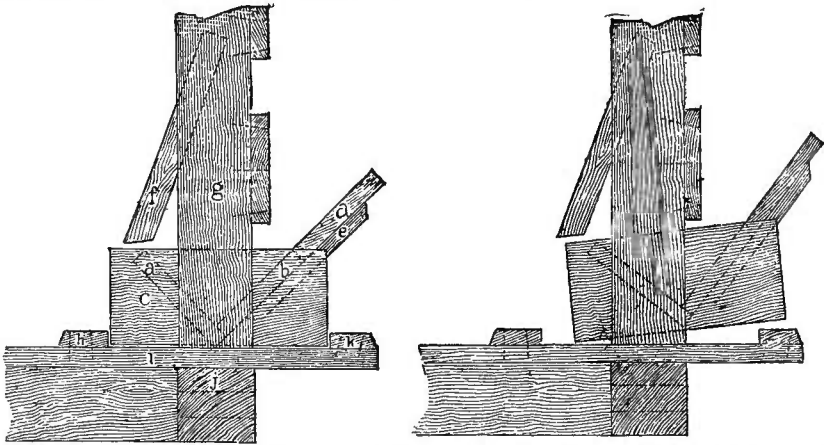

convenient to be had, a 12-in. board may be used for this side of the trough and the extension, *d*, over which the feed is to be poured into the trough. Using a 12-in. board will not make the battens unnecessary. They will be required to keep the wide board from warping or the upper side from splitting off.

The strip *f*, nailed against the inside of the 2x4 corner post, *g*, is intended to keep the pigs from lifting the trough above the stop, *h*, nailed on the floor inside of the stye. The flooring-boards, *i*, extend beyond the corner of the 4x4 sills, *j*, about 7 in., and across the ends of these is nailed the strip, *k*, which serves as a stop in preventing the pigs from pushing the trough out from under the side of the stye or pen.

Fig. 2 shows how the trough can be lifted from its place from the outside.

FEEDING TROUGHS.

With a view of preventing the introduction of disease germs into the system with the food or drink given to hogs the use of good feeding troughs has been insisted on. Such troughs are useful also when disinfectants are to be given internally for the purpose of retarding the development of disease or preventing the further propagation of germs already in the alimentary canal.

Fig. 1, herewith, shows a trough placed against a fence, through which the feed is poured by a chute extending the length of the trough. The uprights at the front prevent the

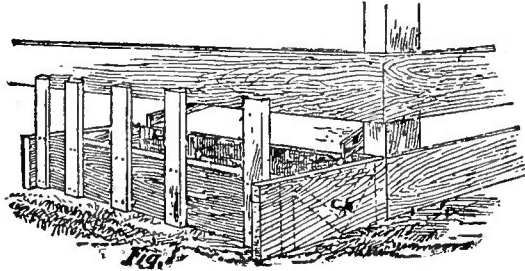

hogs from fighting each other away, and also from putting their feet in the trough. The boards at the front and back are each 6 in. wide and 1 in. thick. The one placed aslant for the front part of the bottom is of the same width, but the one aslant at the back is 7 in. wide. At this trough four hogs can feed together and each has an equal chance. Longer troughs can be made in the same way if desired. They are best made of good oak or other hard wood.

Fig. 2 shows a trough made by squaring a log with the axe and then hewing out the upper side. This makes a good solid trough that can be placed in an open yard and is not easily tossed about by the hogs.

Corrosive sublimate is perhaps the most efficient of all disinfectants known; but it is too powerful a poison to

recommended for general use. Iodine, nitrate of silver, permanganate of potash, chloride of zinc, sulphate of copper, and sulphate of iron have all been found to be destructive of the germs of disease. The following acids have also been found useful in destroying the germs, viz.: carbolic, boracic, sulphuric, salicylic, nitric, and hydrochloric. Sulphurous acid gas and bromine gas have also been used with success for the purpose.

Of all these none can at present be more highly recommended for general use than carbolic acid. It is easily obtained and the cost is comparatively small. Ten drops of a 95 per cent solution may be given for each 100 lbs. of live weight of hog three times a day. It may be given in such swill as the hogs are fond of and are used to taking freely.

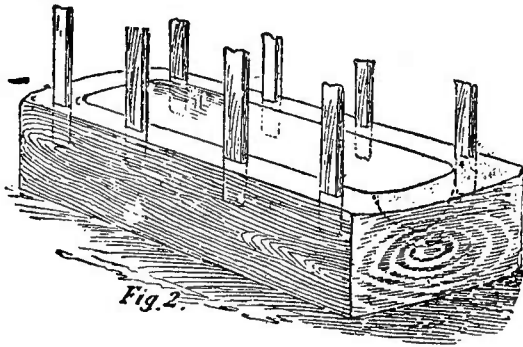

None of the advertised "sure cures" can do more to check the spread of disease than the carbolic acid will do, and it is money thrown away to spend dollars for patent "cures" when a few cents will buy that which will answer as well.

The carbolic acid should also be used externally. To each gallon of water add about one fluid drachm of the acid, and with this sprinkle the hogs from the nose of a watering can. Remove and burn all their bedding and sprinkle their pens and sleeping quarters well with the carbolic acid water. Do this every day or two and rinse well also their feeding troughs with the acid water.

If corrosive sublimate is used to sprinkle the hogs and pens a solution of sufficient strength will be made by adding one teaspoonful to a barrel of water. It is not advised that any of this be given internally.

Sulphuric acid is a cheap and useful disinfectant. One ounce of the acid to one gallon of water will make a solution of the right strength for sprinkling the hogs and the pens.

A COMBINATION HOG AND HAY RACK.

The illustrations herewith given show a device which was originated by Mr. James E. Rodgers of Ostrander, O., and which has come into almost universal use in that part of the country on account of its cheapness and convenience. As a hay rack, to be used in hauling hay, straw, or other bulky farm products, it is very convenient, and the facility with which it may be converted into a rack in which to convey hogs, sheep, or calves to market is surprising.

The engravings need but little explanation. Fig. 1 shows the rack after it is put together as it stands on the wagon to hold the hogs, sheep, or calves, and Fig. 2 shows precisely the same thing when used as a hay rack.

The frame-work is constructed as follows: There are two side pieces (made of oak or other strong stuff, 14 to 16 ft. long, as may be desired,) 2x6 in., and connected at each end, as shown in drawing, by a 2x4 strip fastened firmly by bolts passing through the side pieces as they rest upright in the wagon. Then there are four cross pieces bolted onto the bottom of side pieces, as shown, which are made of 2x4½-in. lumber, the end ones being placed about six inches from end of side pieces. A board 1 in. thick and 12 in. wide is firmly fastened lengthwise of the rack, as shown in Fig. 2. The cross pieces are mortised (4½x1½ in.) with a slanting mortise to receive the supports of the side frames, as shown. These mortises are made 5½ in. from inside of the side pieces. The supports of the side frame-work are made of hard wood and are 3 ft. long; at the bottom they are 2x3 in., tapering to 2x2 at the top, and at bottom of each a tenon is cut to fit into the mortise in cross pieces. There are four of these supports or uprights on each side, as shown, and to these are bolted and nailed four boards 1x4, as shown in diagram. The top of the upright or post is cut at an angle, so that when the top board

is fastened on it will be exactly parallel to the cross pieces at the bottom when used as a hay rack, thus furnishing a convenient footing for a man to stand upon when the rack is in position for loading hay. The top board has usually been made same width (4 in.) as the others, but Mr. Rodgers informs us that he thinks it would be better 6 in. wide. These

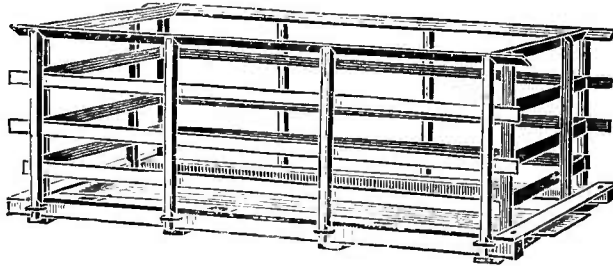

FIG. 1.

boards are both bolted and nailed to the uprights and spaced about as follows: The bottom board $7\frac{1}{4}$ in. from the tenon; space $3\frac{3}{4}$ in.; second board; space $5\frac{1}{2}$ in.; third board; space 7 in.; top board. The end gates are made as shown in diagram, and are held in place by a rod same as the end gate to a wagon bed. The upright for holding the lines is hinged to the top cross piece and may be used or removed at pleas-

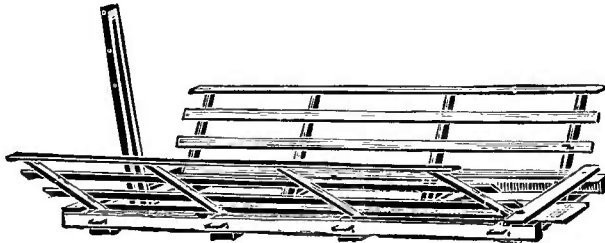

FIG. 2.

ure. The whole rack when completed is in five pieces—bottom, sides, and ends—each piece firmly made and handled separately in putting together for use on the wagon and separately lifted off and hung up when done using. On the outside of each side piece of bottom frame and directly over each cross piece there is a strong iron staple, bolted through the side piece, which holds the bottom of the upright when used as a hog rack, as shown in Fig. 1. These staples are

about $3\frac{1}{4} \times 1\frac{1}{4}$ in the clear, so that the uprights pass readily through them, the bottom of uprights, after passing through, resting on end of cross piece, which extends about $\frac{1}{2}$ in. outside of frame. After the parts are all made first put the bottom frame-work on the wagon, then place the sides in position. If to be used as a hay rack insert the ends of the uprights into the mortises of the cross pieces, so that the upright will rest on the main side piece of bottom frame, as in Fig. 2. Then put the upright for holding the lines in its place, insert the bolt that holds it, and the rack is ready for use. If for hauling swine, sheep, or calves let the bottom of uprights drop into the staples, as shown in Fig. 1, then put up and fasten the end gates and slide in a board of the proper width on each side of the main center board, so as to make a reasonably close floor for the animals to stand on, and the rack is complete. If made of well-seasoned lumber one man can easily handle and place in position any part of it, and it can be readily taken apart and each piece hung up in the barn or wagon house out of the way. It may be made of any size desired, but the dimensions above given are those that are ordinarily used. The iron bolts used are all $\frac{1}{2}$ in. thick.

HELPS IN MOVING HOGS.

For the very convenient device herewith illustrated and described we are indebted to Mr. L. N. Bonham of Ohio:

On every hog farm there are occasions when are needed conveniences for loading large sows and fat hogs. By a little forethought and ingenuity, with a small outlay for material, the farmer can secure labor-saving appliances which directly and indirectly save money. But yesterday a neighbor had sixteen fat hogs to deliver at the railroad. They were turned out of the fattening pen onto the highway to be driven a mile and a half. A bridge across a frozen stream was to be crossed. The farmer and two men worked and coaxed, then kicked and slashed and yelled, and ran themselves and hogs down in their vain efforts to get the hogs to cross the bridge. To cross the ice was impossible. A half day was spent and the

hogs worried shamefully, all for the want of a little gumption.

If he must drive his hogs to market he could have saved time and worry had he scattered some straw on the bridge floor to have given the hogs confidence. A frightened hog becomes as unmanageable as a scared race horse and ten times as stubborn.

It is the part of wisdom to prevent trouble when it can be done. Animals not accustomed to cross bridges are always suspicious of them, and must have time to investigate the situation and decide whether it is safe to risk their precious carcasses on such strange structures.

There is always a doubt, however, what their judgment may be in the case, hence we had better adopt means by

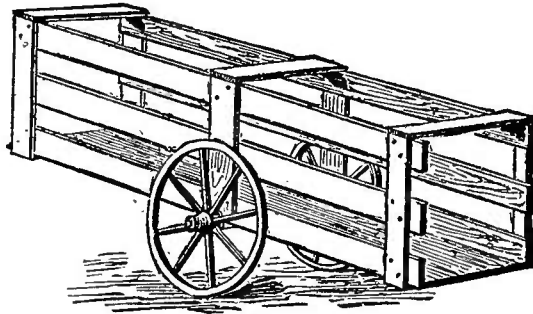

which our schemes may not be so easily upset, as they too often are, by the stubbornness of a hog.

Had this neighbor loaded his hogs into his wagons he could have delivered them in less time with no trouble and no worry and scarcely any loss of weight.

How to load them is the trouble with many farmers. This can be easily done if one has a hog chute, such as I will now try to describe.

The cut will give a general idea of its construction. It is 11 ft. long, 2 ft. wide in the clear, and the sides are 2 ft. 6 in. high. There are two sills made of 2x4 scantling, with tenon 1x4 in. on each end, which enter mortises in side posts 1x6 and are fastened with $\frac{3}{4}$ -in. draw pins. After these are made put in draw pins and tighten them up; then put in the bottom side pieces, which are boards 1 ft. wide and 12 ft. long;

then the two bottom boards, 1 ft. wide and 11 ft. long. If the bottom sills have been made 2 ft. 2 in. between shoulders of tenons the bottom boards and side boards will fit closely and leave no cracks and help to stiffen the sides. Now put on two 6-in. fencing boards 12 ft. long, leaving cracks 3 in. wide, and you have the sides 2 ft. 6 in. high. Now place one end of this chute in the bottom of your wagon which you will use for hauling hogs in, the other end resting on the ground. You can now drop a plumb line and mark and saw off the ends of the side boards so that the ends of the chute will be perpendicular.

The wheels shown in the cut can now be placed so the axle furnishes a support to the bottom of the chute. The bottom will be stiffer if you have placed the sills and side posts or stays one foot from each end. For wheels we have a cast-off pair from an old buggy, such as can be had at any wagon or blacksmith shop for a trifle. The iron axle can be cut in the middle, so as to be made 2 ft. 6 in. between the shoulders of the spindles. Now cut a slot in each of two pieces of 2x4 scantling 3 ft. long, and let the slots be wide enough to fit closely over the square of the iron axle. It is usually about $1\frac{1}{4}$ in. Let these pieces be put on the outside of the chute, the axle in the slots, and when the axle is adjusted so as to touch firmly the bottom of the chute nail these two slotted pieces to the sides of the chute, and you have a hog chute which can be wheeled from place to place with great ease. It will be found more convenient than a permanent chute, since with it hogs or sows can be loaded directly from their accustomed pen.

In many places the wagon bed used is too shallow for hauling hogs. We have found a bed 2 ft. 6 in. deep entirely satisfactory. A cheap rack is easily made to put on top of a common box-bed, as seen on many farms. It makes a handy arrangement for hauling hogs, calves, sheep, stove wood, leaves, and other light, bulky material.

The rack may be kept in place by the uprights entering staples in sides of the bed, or by alternating on the rack so as to slip down closely on each side of the bed.

With a portable chute to load hogs and a wagon bed with

movable racks we find it cheaper to haul hogs to market than to drive them. The shrinkage is less and shippers receive them fresh and vigorous, so they say they do not lose so many in transit on the cars. With a chute and a box or crate it is a light job to move a fine sow and carry her to the boar when we wish to make a cross outside of our own herd.

DEVICE FOR KEEPING SLOP WARM.

Here is a cheap device for keeping slop warm, for which we are also indebted to Mr. Bonham. This cut is to represent a coal-oil barrel, set inside of a box and packed with cut straw or sawdust. There is a lid to close down tight. An old coffee sack or piece of blanket or carpet laid over the

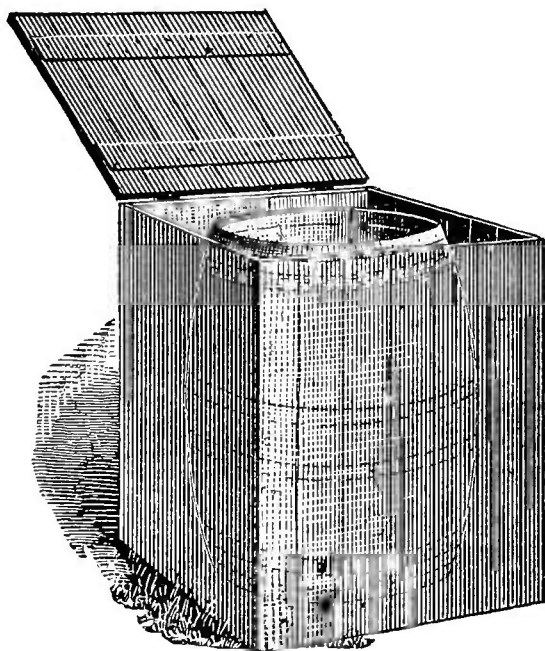

barrel before putting on the lid of the barrel and closing down the lid of the box will keep in the heat.

We make the barrel full of cooked feed. If kept covered it will keep warm until fed out. It is made as thick as mush or cream, and one bucket of the feed mixed with a bucket of

water from the well makes a tepid mess which pigs enjoy and will eat up clean and go off happy to bed or to rambling about the grass lot.

With this jacket around the slop barrel the hot dish-water and all waste hot water of the kitchen or laundry can be utilized to the comfort and health of the pigs. The chill ought to be taken off of any drink given to the pigs in freezing weather if we would get best results for care and feed.

This device may seem small to the farmer who handles pigs and swine by the hundred, but as the bulk of the pork of the country is made by the farmers who handle a few hogs the hints here given will meet their case.

A DEVICE FOR HOLDING HOGS.

A device for holding hogs by the head while ringing them is herewith illustrated. It is simple and cheap in its

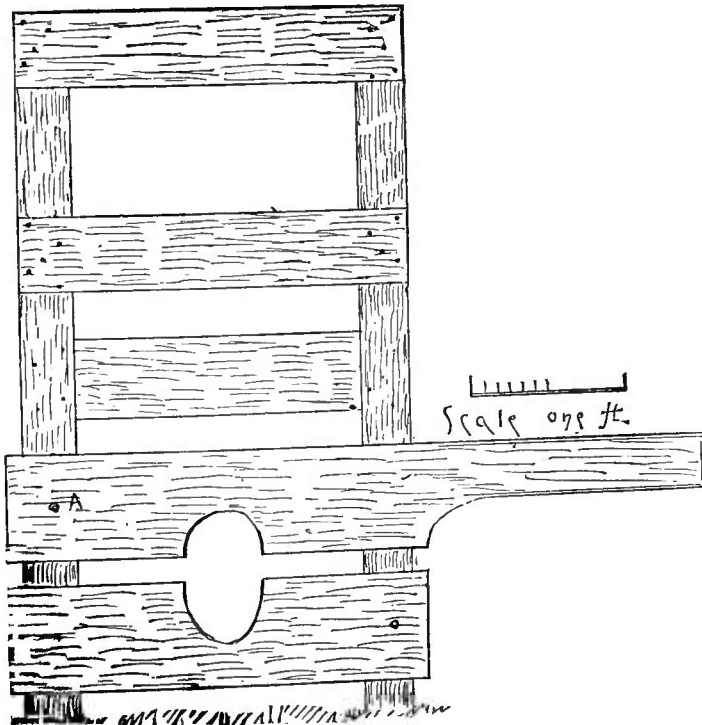

construction and easy in its operation—so simple, in fact, that the mere illustration furnishes all the specifications necessary. The uprights should be firmly set in the ground and the upper piece of the stocks pinioned to the upright on a pivot at *A*. By nailing boards to the uprights on both sides in the rear a small chute may be formed by means of which the hogs may easily be driven into the “trap.”

SILOS AND ENSILAGE.

The use of the silo in the preservation of forage crops has become so important and generally recognized a factor in live-stock husbandry that a volume of barn plans designed especially for farmers would be greatly lacking without some attempt to present the result of the latest and ripest experience concerning their construction. It is doubtful if in any place in America a more persistent, determined, and intelligent effort has been made to get at the very bottom facts connected with the construction of the silo as well as the preparation and manipulation of forage crops so preserved as at the experimental farm connected with the Wisconsin Agricultural College. A little over one year ago Prof. F. H. King of that institution was commissioned to make an exhaustive examination which should embrace the whole subject of silo construction, and the result of his investigations is given herewith as a consensus of the most intelligent experience of practical men throughout the entire country, as follows:

Silo experience in the United States now covers more than ten years, and so far as the economy of producing silage and the advantages of feeding it are concerned there appears to be everywhere, among those who have operated successful silos, a strong conviction that good silage is a superior and cheap feed; but the same experience is now fast demonstrating serious imperfections in the construction of perhaps a majority of existing silos in this country. Some silos have so rapidly deteriorated as to become utterly useless for the purposes for which they were intended inside of three or even two years, unless they are subjected to extensive repairs, while others have never successfully preserved the materials placed in them. With a view to obviating these difficulties in the construction of future silos, and of suggest-

ing remedies for the defects of existing ones, a study of the actual construction and condition of silos now in use has been undertaken. It is the purpose here to record some of the facts observed and to make such suggestions as the present state of the study appears to warrant.

I.—NUMBER OF SILOS EXAMINED.

Thus far ninety-three silos have been examined, of which seventy are in Wisconsin, six in Michigan, six in Ohio, and eleven in Illinois. Of these, sixty-seven are lined wholly or in part with wood; ten are lathed and plastered with water-lime; fourteen are stone, grout, or brick, with cement facing; two are lined with metal, and one with tarred paper.

II.—KINDS AND CONDITIONS OF WOOD-LINED SILOS.

Of the sixty-seven silos lined wholly or in part with wood thirty-four, or more than one-half, showed some rotting at the time of the examination. The oldest of these silos had been filled only five seasons; seven are rotting at the end of the second filling, and one, which was relined at the end of three years, has the new lining rotting after a single year's use. This appears like a dark record for the wood-lined silos, but there is a brighter side when the subject is studied in detail.

We have found five varieties of wood lining now in use, as follows:

1. A single layer of matched boards, of which there are two. One of these is rotting where it comes against a beam in the barn and the other has been used one year only. In the latter of these the silage spoiled a foot in at the corners, and from two to four inches on the sides.

2. Two layers of common boards without paper and unpainted. But one of these was examined, and this was rotting in several places after three years' service. The silage had spoiled to a considerable extent in it, but it should be said that it was built of cull boards, many of which were worm-eaten and even spongy in places.

3. Two thicknesses of boards separated by strips of furring laid upon tarred paper. Of the six silos containing this

type of lining, their average age being 3.33 years, every one has rotted, two of them so badly as to require extensive repairs before the silos are suitable for service again.

4. One thickness of matched boards with paper on the studding. Thirteen of these silos have been visited, six of which, with an average age of three years, are in good condition still, while seven, with an average age of 3.43 years, are rotting more or less.

5. Two thicknesses of boards with paper between, nailed closely and firmly together. There are forty-five of these silos, twenty-six with an average age of three years, in good condition, while nineteen, with an average of 3.4 years, are rotting to some extent.

The rotting which has occurred in most of the cases noted is by no means general, and the conditions under which it has occurred may be thus stated:

1. Rotting where there has been inadequate general ventilation—eight cases.

2. Rotting where stone walls have been faced with wood—eight cases.

3. Rotting where boards came against beams or sills—twelve cases.

4. Rotting where spoiled silage is left piled against the boards—four cases.

5. Rotting where dirt is piled against or lies behind the lining—four cases.

III.—IMPORTANCE OF THOROUGH VENTILATION.

I believe that the rotting in every case we have thus far observed in the walls of wood silos is attributable to imperfect ventilation, and that it might have been greatly delayed if not entirely prevented by different methods of construction.

Wood kept perfectly and continuously dry, or perfectly and continuously saturated with liquids which do not act chemically upon it will resist decay for generations, while almost any natural wood containing a suitable amount of moisture and possessing the right temperature may rot in a very brief period provided only that there be present in it

the living spores or germs which develop and multiply at the expense of the wood tissue.

The ordinary kinds of wood-decay are processes of disintegration due to forms of life which develop from spores and do their destructive work where conditions are favorable; that is, where the temperature is right and the wood is for considerable intervals of time neither too wet nor too dry. This being true it is evident that wood-lined silos should be so constructed that all lumber against which the silage does not lie shall be continuously too dry to permit of decay, while the lining itself should be permitted to become dry and remain so as fast as the silage is removed from it. These conditions may be maintained in all comparatively dry climates, I believe, by adopting modes of construction which insure very thorough ventilation both of the silo pit and within the silo walls immediately behind the lining; but it may be seriously questioned whether in damp climates, where the shingles of houses are largely moss-covered most of the summer, a simple wood lining can last long in any silo.

It will be readily seen that the type of silo lining where strips of furring on tarred paper carry the boards against which the silage rests, forming closed air spaces, is a mode of construction which must necessarily maintain a damp atmosphere behind and in contact with the lining, and every one of the six cases of this type observed has rotted badly. It will be observed that the rotting in the other cases also occurs where the mode of construction or other conditions are such as to necessitate a very slow drying of the silo lining after the silage is removed.

IV.—PAINT FOR THE WOOD LININGS OF SILOS.

The linings of wood silos have been treated in various ways to render them less liable to rot, and the following have been observed: First, linings without paint of any kind; second, linings painted with hot coal-tar; third, linings painted with coal-tar dissolved in gasoline; fourth, linings painted with hot coal-tar mixed with pitch; fifth, linings painted with pitch alone; sixth, linings painted with linseed

oil and red ochre; seventh, linings painted with linseed oil alone.

As far as can be deduced from a study of the cases visited there appears to be very little if any advantage derived from the use of the paints mentioned. Some of the very oldest of the wood-lined silos I find unpainted, and at the same time perfectly sound, while on the other hand the silo having apparently the best coating of paint has rotted more than any other and inside of three years.

If a perfectly impervious coat, which would remain so, could be applied to the wood lining this would without doubt be of great advantage, but the coats mentioned, applied as they have been, leave innumerable places for the silage juices to enter the wood, and when this is the case there are two ways in which the paint may actually hasten the rotting rather than retard it, thus:

1st. By preventing the boards in places from becoming wet enough to keep the fungi from growing there while covered by the silage.

2d. By holding moisture in the boards long enough after the silage is out to allow the spores to develop and destroy the wood.

It is a well-established fact that painting wet or green timber hastens rather than retards decay. It is my impression that if a wood lining is to receive any treatment whatever some antiseptic liquid will be best which will readily penetrate the wood and kill the spores without at the same time injuring the silage which comes in contact with it. There are several antiseptics which may be used, but they should be tested before they are recommended.

V.—STONE AND GROUT SILOS.

We have examined fourteen silos which are stone or grout and twenty-five which are stone or grout below and wood above. The masonry of nearly all of these silos is plastered with one or more coats of some variety of water-lime or cement, and where the work is well done the great majority of the testimony goes to show that the silage is just as good in contact with the masonry, or even better than against the wood.

The water-lime coating, however, is not permanent. Both the acetic and lactic acids of the silage juices act vigorously upon the lime in all varieties of cements, dissolving it out and leaving the mortar a layer of porous sand, which is easily and deeply scarred with the fork in removing the silage and which crumbles and rubs off under the hand. When this condition is reached the layer of cement becomes saturated with the silage juices, and if the walls are not protected from frost it freezes and cleaves off. Where this is not the case in the older silos the absorbed juices undergo a change which results in the development of a very strong and disagreeable odor which I have rarely detected in the wood silos. The quantity of juices absorbed by the porous cement is enough to develop a thick layer of mould, sometimes covering the entire walls in the poorly-ventilated silos, and this on drying cracks and rolls up as mud does in the sun. While it is true that the acids of the silage decompose the cement of the stone silos, still the life of a single heavy coat well put on and protected from frost appears to be at least ten years, and with a yearly whitewashing with pure cement I have no doubt that a single coat of plastering might last twenty to thirty years.

Where the walls of stone silos have been left rough and uneven through insufficient pointing or not plastering them the settling of the silage develops air spaces against the walls, which result in more or less silage spoiling. This fact coupled with another, namely, that the earlier stone silos were comparatively shallow, has been, in my judgment, the chief cause of unfavorable criticism of these structures. The only serious objection I can urge against a well-built stone silo is its relatively high first cost.

It should be noted, however, that whatever neutralizes the acids, especially the lactic, preventing them from reaching that per cent which checks further fermentation, allows these changes to continue, and if the neutralizing effect of the cement extends to any considerable distance into the silo slightly greater losses should be expected when it is used.

VI.—LATHED AND PLASTERED SILOS.

Of this class of silos I have visited ten; one has been filled four times, three three times, and the remainder only once or twice. No one of these silos could be pronounced unqualifiedly sound at the time of my visit. Indeed one had been relined with wood after two years' service; one was being replastered in places, and three others had some of the plastering off—two of them large areas—when they were examined. They all showed cracks and the disintegrating effects of the acids described under the stone silos. There are several very serious objections to using this type of lining:

1st. The springing of weak silo walls and the treading and packing of the silage tend to break the clinches and loosen the plastering.

2d. Careless use of the fork in removing the silage will necessarily perforate and break away the cement.

3d. The softening effect of the acids renders the coat liable to destruction from freezing and permits the silage juices to wet the lath and woodwork behind, and by holding moisture against them after the silage is removed increases the danger of rotting. In the silo which had been relined with wood it was stated that the boards were damp when the plastering was removed a month after the silo had been emptied, and that some of the boards were already rotting. The silo which had been in use four years had been white-washed with pure water-lime each season, and this appears to have nearly neutralized the acids and thus protected the lining, for the only softening in this case was near and at the bottom. Three of this class of silos visited are round, thirty feet in diameter and plastered with hair mortar, to which cement was added when it was applied. Here the greater rigidity of the silo walls, the arched surface of the mortar and the hair in the clinches all conspire to give greater permanence to the lining than in the rectangular silos, and I have no doubt that with very thorough ventilation both of the silo pit and of the walls behind the lath, together with a yearly application of cement whitewash, the lining may last a long time.

VII.—METAL, SHINGLE AND PAPER-LINED SILOS.

We have at the experiment station two silos lined with metal, one with sheet-iron and the other with roofing tin. They have each been in use one year, and in my judgment are not likely to prove satisfactory. None of the available metals are in themselves proof against the acids of silos and it is difficult to coat them in such a way as to entirely shut off the acids. The two varieties of paint used on the linings mentioned came off quite generally and the rusting of the sheet-iron is very noticeable. Roofing-tins are now mostly coated with lead and its compounds are poisonous. I have found it very difficult to coat sheet-iron, even with coal-tar, which the acids do not attack, so as to protect it, on account of the small cavities in the surface containing air, which expands with changes of temperature and blows out, leaving minute pores through which the water and acids enter and eat under the rest of the coating. There is less trouble of this sort with tin, but in either case the fork is certain to cut through the paint and expose a fresh surface to the action of the silage juices; and besides, neither of them can be applied for less than \$50 per thousand square feet.

I have seen but one paper-lined silo and it is very unsatisfactory. The paper was held in place by cleats extending both up and down and horizontally. The paper was badly warped and much torn. The cleats interfere with the settling of the silage and tend to develop air spaces, which causes the silage to spoil on the sides.

The two shingled silos were in a fair state of preservation and the silage is reported to have kept well in them. In these cases cull shingles had been used at sixty cents per thousand.

Such a lining is necessarily less perfect and I believe not as lasting as plain boards, and when good shingles are compared with good lumber the lumber is cheaper.

VIII.—THE FORM AND DIMENSIONS OF SILOS.

An ample depth of the silage is one of the first requisites of its keeping. I have visited silos thirty, thirty-four and thirty-six feet deep, and all the evidence goes to show that

the best silage and the least absolute waste is found in deep silos, while other conditions being the same the poorest silage and the most waste occur in the shallow ones. My conviction is that the best results can hardly be secured with a depth less than twenty-four feet unless very heavy and careful weighting is resorted to. The importance of depth increases when clover or other loose-lying material is cut in, and such material should as a rule be covered with a considerable depth of corn to insure closer packing and a more complete expulsion of entangled air.

In form the silo should be either round or as nearly square as it is practicable to make it, because these forms give the greatest capacity with the least amount of side exposure. The long, narrow silos are needlessly wasteful both of silage and of lumber. I have visited one silo 12x27 ft., only 12 ft. deep, and another 16x48 22 ft. deep. Now a silo 32 ft. square will have the same amount of side exposure as the one 16x48, and for the same depth will hold just one-third more; while the same amount of side in a round silo will enclose more than two-thirds more silage and will require much less lumber to build it, because 2x4 studding may be used, the siding and lining acting as hoops, giving the needed strength.

IX.—THE IMPORTANCE OF FEEDING FROM THE TOP AND THE USE OF PARTITIONS.

In the construction of silos careful attention should be paid to the area of surface exposed in feeding the silage. Silage wastes much more rapidly when fed from the sides than from the top, and since the most economical construction demands the largest possible feeding surface it follows that the feeding should be, in general, from the top.

The proper horizontal area of the feeding pit depends upon the amount of silage fed daily and the rate at which silage becomes seriously injured when exposed. I have not been able to gather facts enough to settle this important point. The spoiling is certainly more rapid in the shallow than in the deep silos and more rapid when corn or clover is put in whole than when cut, because it is impossible to feed

the surface down as evenly and keep it as smooth. My impression is that the silage should be lowered at least two inches daily, and that three would be better. Taking three inches as the depth fed daily, forty as the number of animals, 150 days as the feeding period, and 1.5 cubic feet as the amount fed to each animal daily, a round silo 17.5 ft. inside diameter and 37 ft. deep would be required. The same conditions would also be met by a round silo 22 ft. inside diameter, 24 ft. deep, with a partition through the center.

Where all the silage can be fed conveniently from one point and a large amount of silage must be stored, one silo with partitions is not only much cheaper, but better than separate structures because the additional corners cannot admit air from the outside when the pits are full and the round silo with partitions makes less corners than the rectangular ones do.

Two-inch partitions give ample strength where the filling takes place on both sides at once, and if it is desired to fill one pit faster than the other temporary braces may be placed in the empty pit and removed as it is filled. I believe that two thicknesses of boards with paper between makes a better partition than the two-inch plank, which appear to be more commonly used.

X.—SMOOTHNESS OF SILO WALLS ESSENTIAL.

Whatever tends to the expulsion and exclusion of entangled air must conserve the silage, and whatever tends to leave or form cavities in which air can lodge in bulk, experience shows leads to spoiled silage. Cross-rods, overhanging ledges and projecting stones should be avoided, as they hold up the silage, forming cavities into which air collects, enabling the moulds to grow.

XI.—THE COVERING OF SILAGE.

When the feeding of the silage does not begin very soon after the completion of the filling a good covering lessens the waste. I have found the following practices in regard to covering:

1st. Some do not cover at all and have six to twelve inches of waste.

2d. Some have used straw with no gain and possibly greater loss.

3d. Many use green marsh hay cut on, and sometimes wet, with good results.

4th. A few use chaff with good results.

5th. One has used boards covered with eight inches of dry earth, which is used afterward in the stable as an absorbent. Silage keeps well.

6th. One used straw weighted with stone with poor results.

7th. Some used cut marsh hay covered with plank, the cracks between planks covered with boards, and the whole weighted with stone. Little loss except at edges and corners.

8th. Others use a layer of cut straw, then boards, then tarred paper and boards again. Keeps perfectly except at edges and corners.

9th. Still others have used first paper, then boards, and these weighted with stone, with good results.

The testimony in regard to covering is quite discordant. Some claim good results with a given method, while with others it has failed. Some have good results one season and very different results another with the same method. We need much more positive knowledge on this point than is now available.

XII.—PROTECTION AGAINST RATS.

Nine of the silos visited have been invaded by rats. They usually enter by burrowing under the foundation walls, coming up inside even where cement has been used. But in some cases they have found entrance to the dead-air spaces, then cut holes through the linings, usually at the corners. Their destructive effects result from the admission of air to the silo, and when it is said that one man reports killing twenty-six rats in a silo the possibilities of damage to silage by this nuisance can be appreciated.

The surest safeguard against them appears to be covering the bottom of the silo with a layer of small stones or grout before the cement is applied. When the cement is applied directly upon the ground the action of the acids soon softens

it to such an extent as to permit the rats to penetrate it without difficulty.

XIII.—PROTECTION AGAINST FREEZING.

If we should be guided in the construction of silos by the general testimony in regard to the liability of silage freezing, the statement would be that very little attention need be paid to this point.

It must be borne in mind, however, that most of our silo experience has been gained during the past three years, when the winters have been exceptionally mild. Those owning older silos do speak of silage freezing, and some of the stone silos testify to the destructive effects of frost. The general verdict is that the freezing, so far as silage is concerned, is more an inconvenience than serious loss. When the frozen silage is mixed with the rest it quickly thaws and is apparently relished as well as if it had not been frozen. All types of cemented silos must be built frost-proof to prevent the cement from cleaving off; but with wood silos the construction required to preserve the silage and to protect the frame from weather appears to be sufficient to prevent any serious freezing during all except protracted extremely cold weather.

XIV.—CONSTRUCTION OF WOOD SILOS.

At present prices there is no available material on the market which can compare with wood in cheapness of first cost; and if a mode of construction can be devised which will insure permanency to the frame work, and at the same time give an effective service of, say, ten years to the lining, the essential demands of a material for silo building will be met by it. The fact that we have perfectly sound all-wood silos of five years' standing which embody only a portion of the principles essential to long life is encouraging for this type of construction. I believe there need be no question about the entire adequacy of the wood frame and the covering outside, above ground, and I have great hopes for the wood lining.

In the construction of a wood silo it is important to have

in mind the conditions essential to durability, and some of them will be here stated:

1st. Only sound and well-seasoned lumber should be used. I have mentioned the case of a second lining rotting in a single season. In this case the new boards were placed directly against those which were rotting, an equivalent to adding wood to fire; and when unsound lumber is used it is very likely to contain either the spores or living fungi which only require the dampness of the silo and its warm temperature to carry forward their destruction. Sapwood, too, is much more subject to rot, because it contains more food upon which the fungi subsist; hence the sappy ends of studding should be turned up and the sappy edges outward. The soundest boards should be reserved for the lining and the very best placed at the bottom.

2d. Wherever the conditions are favorable for the rotting of silage there it is quite possible for the silo lining to rot also, as my observations have shown, and since ample depth insures better silage it may also be expected to better preserve the lining. I have not met a man who unqualifiedly says his silage is as good in the corners as at most other places along the sides; hence I feel that rotting of the linings at these places is likely to take place, and for this reason and because it is stronger and cheaper the round form, wherever it can be used, is preferable to the angular silo.

3d. The large number of observed cases of rotting where dirt, stone walls, beams or sills hold dampness behind the silo linings, coupled with the cases of rotting which have occurred where there has been imperfect general ventilation, show that perfect ventilation on both sides of the lining is one of the first essentials to its preservation; hence horizontal studding and the placing of linings directly against beams or sills should be avoided as well as the lining of stone walls with wood.

Silo Linings.—In the majority of cases the best results have been associated with the lining consisting of two layers of boards with tarred paper between them, but it does not appear essential that either should be matched; they should be of uniform thickness, however, and the narrower widths

are best. On account of the conditions which work for and against the rotting of linings I believe a still more effective and durable lining may be secured by painting both layers of boards on one side only with hot coal-tar boiled until it is not sticky when cold. The tarred sides should be placed face to face in the silo, tarred paper between them, and I would urge the painting of the paper with cold coal-tar after it is in place but no faster than the inner lining is put on. The coating of the boards may be readily done by boiling the tar in an iron kettle three feet in diameter, letting one man slide the boards across the top while another paints them with a well-worn broom. The tar should be laid on smoothly and the boards placed horizontally to cool. After boiling the tar down to the proper consistency there should be enough fire only to keep the tar hot. A wide board should be at hand to throw over the top of the kettle to smother the flames in case the tar should take fire from overheating.

It would be less trouble, perhaps, to put on the first layer of sheeting and paint it, in place, with coal-tar boiled until it is as thick as it will spread readily when cold. By painting the first lining and placing the paper, and painting this just before the second layer is put on, a very impervious wall must be secured. Such a treatment of the lining would prevent the outer layer from becoming damp, allow the inner to dry more quickly after the silage is removed, besides rendering both more impervious to air, and it would seem must be a great improvement at small expense, but only a trial for a series of years can positively settle the matter.

The Sills.—These should rest on a good stone wall, well bedded in mortar after having their under sides and inner edges painted with coal tar, as described for the lining, and they should be everywhere at least 6 in. above the bottom of the silo inside and 8 in. above the earth outside.

Fig. 1 shows the construction of an all-wood round silo. Sills 2x4 cut in sections on a radius of the silo circle, bedded in mortar and toe-nailed together. Plates the same, spiked to tops of studding. Studding 2x4, 1 ft. apart. Short lengths may be used, lapped to get the depth. Sixteens and fourteens will give a silo 30 ft. deep. Lining made from fencing

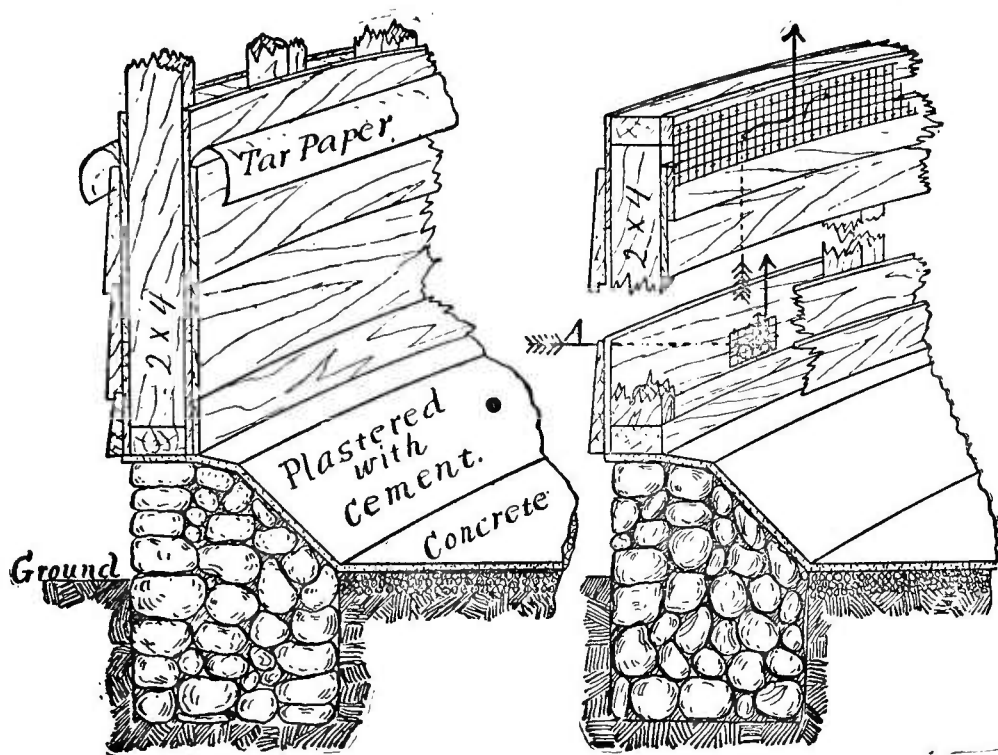

FIG. 1.

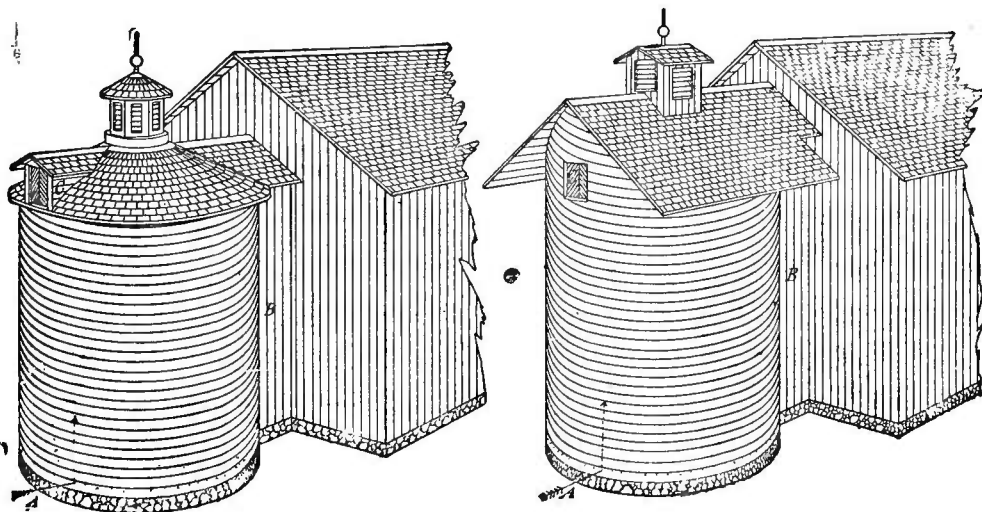

FIG. 2.

ripped in two. Outside sheeting the same. Siding for silos under 28 ft. outside diameter, common siding rabbeted; for silos more than 28 ft. outside diameter common drop siding or shiplap may be used. *A* shows ventilators between studding. Auger holes are bored at bottom between studding, and the boards lack two inches of reaching plate at top inside. Both sets of openings are covered with wire cloth to keep out vermin. There should be a line of feeding doors from top to bottom, each 2 or 3 ft. by 5 ft., and about 2.5 ft. apart.

Fig. 2 shows two methods of roofing round silos and the manner of connecting them with a barn. *A A* shows where air is admitted between the studding to ventilate behind the

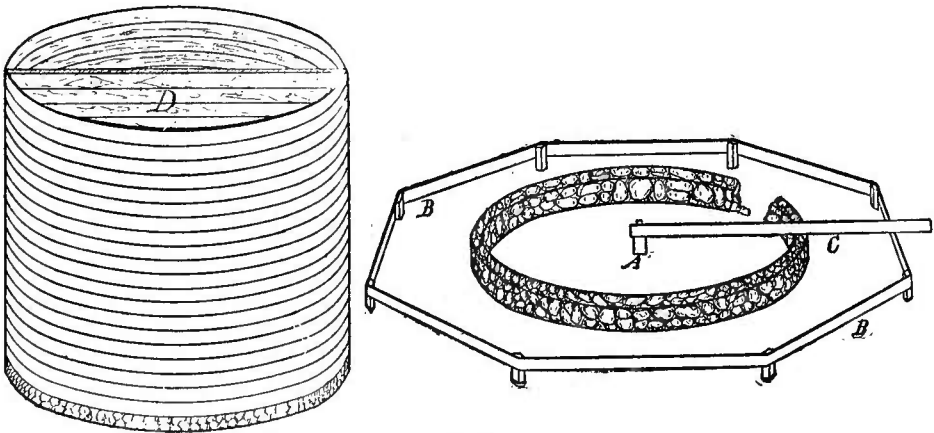

FIG. 3.

lining. *B B* the feeding chute. *C C* filling window. The cupola is essential for perfect ventilation.

Fig. 3 shows method of laying and leveling foundation of a round silo, and a round silo with a single partition. *A*, center post with top level with top of proposed wall. *B B*, straight-edge boards nailed to stakes driven in ground. *C*, straight-edge fixed to turn on a pin at *A*. *B B* are all nailed level with top of post *A*. *D*, partition in round silo. It may be placed so as to come in the middle of the single line of doors, letting the same doors answer for both sides.

In the rectangular silos, where they are deep, the sills must be anchored with iron rods, as shown in Fig. 4, but in

the round silo this is unnecessary. Fig. 4 shows how the studding should be placed on the sills and beams, if in a barn, to insure ventilation.

Fig. 4 shows the construction and ventilation of the walls of a rectangular silo. The sills are two inches narrower than the studding, to leave air spaces between sills and lining. *A* is two inches of mortar made by stirring sand into coal-

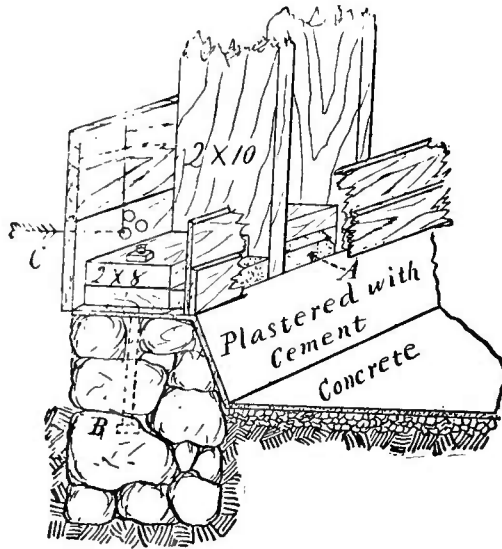

FIG. 4.

tar, boiled until it is hard when cold. *B* is bolt anchoring sill to wall, placed about four feet apart. *C*, ventilator between studding.

XV.—COMPARATIVE EXPENSE OF DIFFERENT KINDS OF LINING FOR ROUND SILOS.

Taking 2,000 square feet of lining as the unit of comparison we shall have the following results for different kinds of lining:

1st. For all-wood lining with paper and coal-tar between two layers, counting fencing ripped in two \$18 per M, tarred paper two cents per pound, tar \$4.50 per barrel, and labor \$2.50 per day, we shall have: Lumber, \$36; labor, \$7.50; paper, \$8.05; tar, \$4.50; total, \$56.05.

2d. For lathed and plastered lining, other items as before

and lathing and plastering at nineteen cents per yard, we shall have, as above, \$56.05; lathing and plastering, \$42.20; total, \$98.25.

3d. For metal lining, taking other items as in No. 1, and sheet-iron or tin laid on at \$5.50 per square, we shall have, as in No. 1, \$56.05; metal lining, \$110; total, \$166.05.

4th. Lined with brick set on edge, laid in cement and spiked to studding, counting brick \$8 per M, mortar and laying \$4.50 per M, one thickness of half-inch wood lining at \$9 per M, and painting with hot coal-tar inside at five cents per yard, we shall have. Lumber, \$18; carpenter labor, \$3.75; paper, \$8.05; brick, \$64; mortar and laying, \$36; painting with tar, \$11.10; total, \$140.90.

5th. Lined with wood with heavy tarred roofing felt at \$4 per M between the linings instead of tarred paper, we shall have, as in No. 1, less tarred paper and tar, \$43.50; roofing felt, \$80; total, \$123.50.

The best qualities of heavy roofing felt would make a very impervious wall when placed between two layers of boards. The brick lining I believe would be practically permanent, but the lathed and plastered ones I would not recommend. The difference in the first cost of a good brick lining and a good wood lining is likely to be more rather than less than that given, which is $\$140.90 - \$56.05 = \$84.85$, and 5 per cent interest on this difference is \$4.24 per annum. Which would be the cheaper in the end must turn upon the relative lengths of life of the two, a matter which only time can settle.

The different kinds of lining here considered would cost some more for rectangular silos, because in them half-inch lumber will not answer. Inch boards are absolutely essential for stability in these forms.

XVI.—THE CONSTRUCTION OF STONE SILOS.

I have visited some very excellent stone silos in Dodge Co., Wis., one of which is 14x24 inside, and 30 ft. deep, 22 ft. above ground. It is covered outside with dimension boards battened, extending up and down and nailed to 2x4 studding held in place by hooked pieces of band-iron laid in the wall.

Its cost was \$500. There are several silos built on this general plan in the same locality, one of ten and another of seven years' standing, which have not frozen. They keep the silage excellently, but the cement is fast softening.

XVII.—COST OF THREE TYPES OF SILO COMPARED.

We give below the cost of a thoroughly-built rectangular silo, and of a round one having the same capacity and depth as the stone one whose cost was \$500.

In these bills the prices of materials have been set at rates locally prevailing, and the cost of carpenter labor has been placed sixty-five cents per M above what I know similar work to have been done for where the carpenters were boarded:

Rectangular silo, 180 tons—14x24 inside, 30 ft. deep.—Foundation, 13.44 perch, at \$1.20, \$16.13; studding, 2x12, 28 ft., 4,704 ft., at \$20, \$94.08; sills, etc., 2x10, 26 ft., 206 ft., at \$19, \$4.94; sills, etc., 2x10, 16 ft., 426 ft., at \$14, \$5.96; rafters, etc., 2x4, 20 ft., 400 ft., at \$16, \$6.40; roof boards, fencing, 450 ft., at \$15, \$6.75; shingles, 5 M, at \$3, \$15; drop siding, 8 in., 2,779 ft., at \$16, \$44.46; lining, surfaced fencing, 4,256 ft., at \$15, \$63.84; tarred paper, 426 lbs., at 2 cents, \$8.52; coal-tar, 1 barrel, \$4.50; painting, 60 cents per square, \$15; nails and hinges, \$10; cementing bottom, \$5; 18 $\frac{3}{4}$ -in. bolts, 18 in. long, \$2.70; carpenter labor at \$3 per M and board, \$41.16; total, \$344.44.

Round silo, 180 tons—20 ft. inside diameter, 30 ft. deep.—Foundation, 7.5 perch, at \$1.20, \$9; studs, 2x4, 14 and 16 ft., 1,491 ft., at \$14, \$20.93; rafters, 2x4, 12 ft., 203 ft., at \$14, \$2.91; roof boards, fencing, 500 ft., at \$15, \$7.50; shingles, 6 M, at \$3, \$18; siding, rabbeted, 2,660 ft., at \$23, \$61.18; lining, fencing, ripped, 2,800 ft., at \$18, \$50.40; tarred paper, 740 lbs., at 2 cents, \$14.80; coal-tar, 1 barrel, \$4.50; hardware, \$6; painting, 60 cents per square, \$13.20; cementing bottom, \$5; carpenter labor at \$3 per M and board, \$33.17; total, \$246.59.

The three silos are outside and wholly independent structures except the entrance and feeding chute shown in Fig. 2, which connects with the barn. This method of connection

for outside silos, while a little more costly, I feel confident is much the best in the long run.

There is no practical difficulty in filling a silo thirty feet above the cutter. I have visited one filled twenty-eight feet above and several twenty-four feet. The carrier of course must be longer, but the increased labor is relatively small. A filling window at a lower level may be and is in some cases provided, to be used at first.

XVIII.—BUILDING A GOOD SILO BY DEGREES.

It is much better and cheaper in the end to start with the intention of building a thoroughly good silo, and it is possible to do this when money enough cannot be commanded at the outset. In building the round silo referred to, costing \$246.59, it may be put up and used one or even two years before it is completed. To illustrate, in this case the siding, outside paper, painting and cementing the bottom may be deferred one or even two years if really necessary, the only serious inconvenience possible being the freezing of the silage. This would diminish the immediate cost \$94.76, making the first year's expense \$151.83.

XIX.—SUGGESTIONS REGARDING THE REPAIR OF EXISTING SILOS.

The matter of ventilation is the first point requiring attention. This can be secured in most of the silos which have carefully constructed dead-air spaces by removing the upper board next to the plate or by sawing out sections between each pair of studding. These openings may be covered with netting as shown in Fig. 1 if desired.

Where paper has been placed against the side of the board and strips of furring used to carry the lining, I believe the best way will be to remove the lining, take off the strips of furring and apply sound lining directly to the paper, putting on new paper where the old is injured.

Where stone walls have been faced with wood and the lining is rotting the wood should all be removed and the wall plastered, so as to be a little more than flush with the lining above, and those who have walls which set back under

the lining above should face them out flush. A jog outward into the silo below is often admissible, but the reverse never.

Where only small patches of lining are rotting it may be best to cut out the rotting wood and paint the edges well with carbolic acid or creosote oil to kill the germs. Then fit in a block and nail over it a piece of tin and paint this with a coat of hot, thick coal-tar.

Where dirt has been banked against the lining it should be removed and the bottom lowered enough to let the boards become dry when the silage is removed.

Rotting silage should not be allowed to remain in the silo. When it must be left for a time it should be thrown into the center away from the walls.

The cases of rotting against sills and beams are the most difficult to meet. It is of course important to prevent the rotting from extending to the sills, and in some of the cases this may be done by providing ventilation behind the lining and then removing the lower two feet of lining, facing each stud with a wedge-shaped strip about an inch thick at the bottom, letting it extend downward across the sill. Then when the lining is restored and the wall below made flush with it the ventilation will help to protect both sill and lining.

THE BUILDING AND FILLING OF SILOS.

An earlier statement touching the building and filling of the silo was given by Mr. L. H. Adams, in a bulletin of the Wisconsin Agricultural Experiment Station, as follows:

LOCATION OF SILO.

When possible the silo should be located in the feeding barn, since it not only brings the cost of building within the reach of everyone who is really in need of a silo, but greatly facilitates the handling of the silage when feeding it out. Depth in a silo is always preferable to breadth, so that in the case of basement barns it is advisable to let the silo reach from the top of barn posts to the ground floor of the base-

ment; a door or opening can then be made from the silo directly into the basement where the silage is to be fed. The next best location is adjoining the feeding stable. In most dairy stables the cows are stanchioned in two long rows facing each other, and whenever it is possible it should be arranged so that the silo can be entered from the end of this feeding alley. A wooden track can be laid along the center of the feed-way and into the silo, upon which a low-wheeled car can be operated to distribute the feed. If the silo building is located entirely separate it should be planned to load the silage into a cart, which can be driven into the feeding barn, thus delivering the silage with little labor directly to the cattle. The idea of convenience should not be lost sight of, for by exercising a little thought and judgment the labor of waiting on the stock through the long feeding season can be greatly reduced.

FORM OF SILO.

In a square silo less lumber is required and less silage is exposed to the walls in proportion to the capacity than in a long narrow building; it is the part of economy to retain as nearly the form of a cube as the location and other circumstances will admit. Theoretically a circular silo comes the nearest to perfection, for this form requires the minimum amount of material and does away with the corners, in which there is always more or less decayed silage, but as we have had no experience with this form of building nothing can be said about it in this connection.

BUILDING THE SILO.

The following detailed description of how to build will apply to the outside silo, built separately or as an annex to the stock barn.

It is always the part of wisdom to provide substantial foundations for farm buildings that are intended to be permanent, and the silo is no exception. An eighteen-inch stone wall should be laid deep enough in the ground to be beyond the action of frost, and raised high enough above the surface to admit of sufficient grading to divert all surface water; if the location be a high and well-drained one there will be no

necessity for raising the wall more than six inches above the surface. In digging the trenches throw enough earth inside to raise the silo floor up to the top of the stone wall. Upon this stone foundation a sill made of three 2x10 planks should be bedded in mortar (see Fig. 1). In laying the sill the top plank should not be fastened to the others, but left loose, for reasons soon to appear. The studding should be 2x10 plank, preferably 18 ft. long. After carefully sawing the studs to a uniform length and squaring both ends, arrange them in a horizontal position, resting on the edges, and placed sixteen inches apart; they should be supported on a level with and at right angles to the sill upon which the bent is to be raised. Then spike the loose plank of the sill to the foot of the stud;

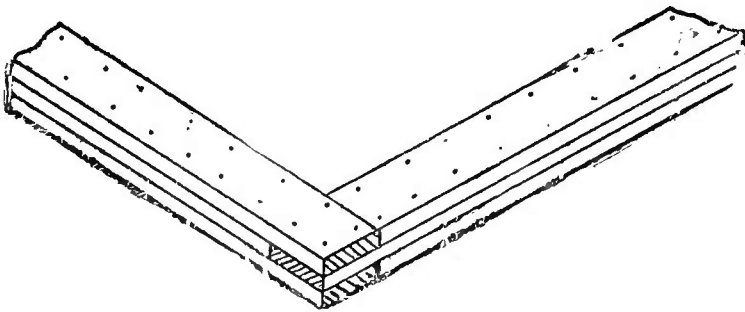

FIG. 1.—SHOWING HOW PLANKS OF SILL ARE JOINED.

and when all have been firmly fastened as directed they should be secured at the top in the same manner. After fastening the studding to sill and plate-planks the side or end, as the case may be, is ready for raising. After the bent has been raised in a vertical position to its place on top of the other two planks of the sill the third one, that was nailed to the foot of the studding before the bent was raised, can be firmly spiked to the lower ones. This first bent can be held in place by temporary stays until the remaining sills are raised; the plates can then be nailed to the corners, and the skeleton frame is complete; two 2x10 planks will give all the strength necessary for the plate. It will be observed that by following this plan the studs are securely fastened, top and bottom, and the full strength of the sill and studding is saved, there being no mortises cut in the sill and no tenons

on the studding. After the frame is up the next thing to be done is to bridge the studding (see Fig. 2). This is a very simple thing to do, but of so much value in strengthening the walls that it ought never to be omitted in a silo. In case

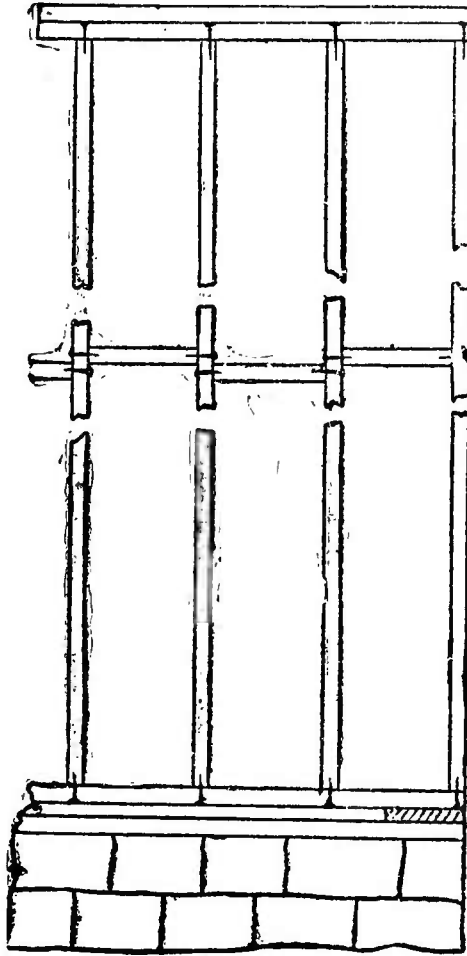

FIG. 2.—SHOWING FASTENING AND BRIDGING OF STUDDING.

the silo is eighteen feet deep it would be advisable to put in two rows of bridging. By thus spiking planks between the studs it makes it just as impossible for the studs in the center of the wall to spring out as it is for those nearest the corners. We are now ready to commence lining the silo,

Each one can follow his choice as to the outside covering, since it plays an unimportant part in the preservation of the silage; some will prefer to use drop-siding or shiplap, others common lumber, and in some parts of the State it is possible to put on a covering of low-grade shingles cheaper than any other way. It is not necessary for the preservation of the silage that paper be used on the outside of studding, but to keep out frost it is advisable to use it, since it makes the silo much warmer. Since a good deal of moisture rises from the silage it is well to provide for ventilation at the roof. This can be done by openings in the gable ends of the building or a dormer window in the roof. It is much better to carry off the moist air by ventilation than to have it congeal on the rafters during cold weather and drop back again when mild days come.

LINING THE SILO.

Care should be exercised in lining the silo. The lumber for this should have no knot holes and should be dressed on one side, and is better if edged so that the joints will be reasonably tight. The lumber need not be of uniform width, but boards from eight to ten inches wide are preferable. The inside of the studding is first covered with boards laid horizontally (see Fig. 3), ten-penny nails being used; building paper is then tacked over the whole surface. Upon the paper nail a second layer of boards. Care should be taken to break joints, which can be indicated by chalk marks on the paper. This double lining, with paper between, must reach from the top of the silo to the bottom of the sill.

The floor of the silo need be nothing but the earth; as already mentioned, it is a good plan to fill in the silo until the floor is on a level with the top of the stone wall; a layer of straw spread on the bottom before commencing to fill with corn will prevent the loss of any silage.

The silo should be tied across the top at two or three places with joists or a cheap cable; this latter may be made by twisting three strands of galvanized wire which costs about three cents per pound; five pounds will make a cable sufficiently long to reach across an ordinary silo.

If the silo is more than thirty feet long the sills should be

secured at two or three places with a cable of this kind, which, as it rests on the ground, is entirely out of the way. The modern silo will not tolerate partitions of any kind; they are relics of the past. There are several methods employed for cutting off the four corners of the silo. Perhaps the simplest plan is to bevel the two edges of a foot-wide plank and nail it securely in a vertical position in the corner. A dormer window in the roof of the silo affords a satisfactory means of getting the corn into the silo in the fall.

The doorway may be formed by cutting out a stud from the sill two-thirds of the way up to the plate. With large silos the doorway should be made sufficiently large to permit the entrance of a cart or some other vehicle for moving the silage from the silo to the cattle. There is no necessity for running the doorway to the top of the plate, since the silage always settles considerably, and even if it fills the silo above the top of the doorway there is little trouble in digging down just at that point and making an opening. Of the numerous doorways described the simplest form is probably the best. Tack cleats on each of the studs which form the sides of the doorway, so that boards six inches wide, running across the doorway, come just flush with the inner lining of the silo. If the doorway is wide, set a stud in the middle to prevent the boards springing. Repeat the cleat and boards for the outside wall. During filling, as the silage accumulates, place a layer of paper across from cleat to cleat and tack on six-inch boards until the doorway is closed; or it may be closed up at once when filling commences and the silo entered by a ladder reaching a doorway on top of the plate. In opening the silo the boards can be knocked off as the silage is fed down.

HOW TO PAINT THE INSIDE WALLS.

Now that the silo is built the question naturally arises, What is the best and cheapest wood preservative that can be applied to the parts of the silo that come in direct contact with the moist silage? An examination of one of the station's silos that had been treated with a coat of coal-tar shows

that one season's exposure to the silage had not affected the wood in any manner. This coal-tar possesses another great advantage over ordinary oil paints, there being so much body to it that it readily fills up all cracks in the lining and aids greatly to make the silo air-tight. It is one of the waste products in the manufacture of gas, and can ordinarily be ob-

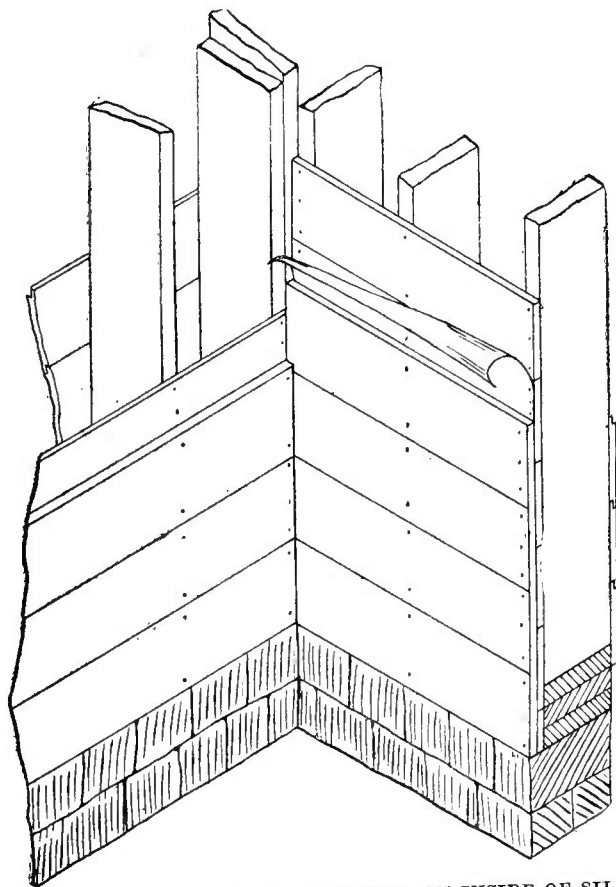

FIG. 3.—SHOWING DOUBLE BOARDING ON INSIDE OF SILO.

tained in any quantity at gas works at \$3 or \$4 a barrel. As it comes from the gas works it is a liquid of about the same consistency as molasses, and it is necessary to burn off considerable of the oil that it contains before it is in a condition to apply to a wall. This burning is a simple process; pour a quantity of the liquid into an iron kettle, set fire to a handful

of straw and throw it in the kettle. The tar at once flashes up and burns with great heat. In order to tell when it has become sufficiently reduced thrust a stick into the blazing kettle, then take it out and plunge it into a pail of cold water; when the tar clinging to the stick has become sufficiently cool to handle take a particle in the hand and pull it out; if it will string out in fine threads a foot or more long it has burned long enough, and the fire can be put out by placing any tight covering over the kettle. It usually takes from one-half to three-quarters of an hour to reduce the tar to the proper consistency. This preparation must be applied hot, and it will be necessary to swing the kettle up from the ground and keep a fire under it until the work is done. The odor and smoke from the hot tar is very disagreeable, but by taking small quantities of the liquid and applying it very hot with mops or whitewash brushes the surface can be gone over rapidly.

A single season's experience with a wood preservative cannot count for much, but we think very favorably of the method here described, and intend coating the walls of a large silo with coal-tar the coming season for an additional test.

HANDLING FODDER-CORN.

The cost of putting corn into the silo depends largely upon the advantage we take of all the little devices that are calculated to lighten and reduce the labor of harvesting and drawing to the silo. By the use of the old self-rake reaper for cutting in the field, and conveniently equipped wagons for hauling, corn can be cut into the silo for from fifty to seventy-five cents per ton and there will be no more hard work connected with it than there would be in harvesting a clover or grass crop. Many farms are supplied with low-wheeled wagons or trucks, but when the silo-filling time comes there is usually a greater demand for vehicles of this kind than the ordinary farm can supply. A very simple and practical way of equipping the ordinary high-wheeled farm wagon is shown in Fig 4. This rack was observed in use on the farm of Hon. Hiram Smith of Sheboygan Falls in the fall of 1888. It is made of 2x8 plank, sixteen feet long, one

end of each being placed on top of the forward bolster; the other ends pass under the rear axle and are chained or bolted up tight to it; these two pieces make the foundation of the rack. The wagon is coupled out as far as these planks will allow. On top of the plank are placed four cross-pieces, equally distant from each other, as shown in the figure. These cross-pieces are 2x4 and should be about seven feet

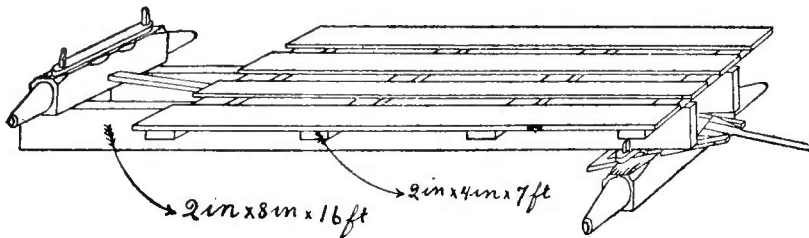

FIG. 4.—RACK FOR DRAWING FODDER-CORN.

long; upon these are laid inch boards parallel with the wagon. The load is of course placed wholly in front of the rear wheels, but the rack is sufficiently large and low enough to enable a man to put on a ton of green corn from the ground without having to climb up on the load or hand it to a second person to deposit.

LENGTH TO CUT.

While it is true that silage cut fine may pack somewhat closer than that cut long, it is doubtful whether there is any material gain in the operation; by cutting fine more of the inner parts of the stalks are exposed to the air, and perhaps more fermentation induced than with longer cuts. So far as our experience goes there is nothing gained by cutting fodder fine instead of coarse, provided that the cattle eat it equally well in both cases; the gain in cutting, which is often very great, comes mainly from getting consumed that which would otherwise be wasted. In the case of silage, there being no necessity for cutting the fodder in order to have it eaten, the length of the cut appears to turn upon somewhat closer packing on the one side and extra expense of fine cutting on the other. It is recommended that cuts as

long as two or three inches be tried with some of the fodder and the results reported; if such long cuts are satisfactory the expense of making silage will be considerably decreased. With ample power and a good feed-cutter it will be more economical to cut fodder and run it into the silo by a carrier than to attempt to fill with long fodder.

USE OF A CHUTE.

The carrier should deliver the cut corn as near the middle of the pit as possible. Until the silo is nearly filled a chute can be used to convey the material still further toward the desired position in the pit. The chute should have sufficient slant so that the cut corn slides off readily. By changing the direction of the chute from time to time the labor of distributing the cut corn can be reduced to the minimum.

FILLING THE SILO.

When corn has reached the proper stage of maturity it is not necessary that it be wilted before putting into the silo in order to make the so-called sweet silage; only the immature fodder needs wilting; such should be wilted from twenty-four to forty-eight hours, if possible, before cutting into the silo. Varieties that mature, if left until the ears begin to glaze, can be put into the silo immediately after being cut with satisfactory results, provided there is no outside moisture on the corn as it goes into the silo; nor is it necessary to suspend operations every other day in order to let the silage in the silo reach a certain temperature before filling can be continued. If the corn is sufficiently mature, and is put into the silo without rain or dew, there need be no fears about the quality of the silage, whether put in slowly or rapidly. At the station last fall we filled a pit with fresh, sufficiently matured corn in one day, and had first-class sweet silage. Recent experience has taught that there is a limit to putting dry or excessively wilted corn into the silo beyond which we dare not go. When the corn has lost enough water to cause the leaves to rustle and break in handling it does not pack closely enough in the silo to exclude the air, and on opening the pit it will be found that the silage is fire-

fanged and permeated all through with a white mould. There is another reason why the corn should not be allowed to become so dry even if there was no trouble about its keeping in the silo; when we put dry corn into the silo we have lost the succulent feature of the silage that makes it especially desirable. Having once commenced to fill the silo the work can be crowded right along by observing the conditions mentioned.

The practice, each morning during filling, of removing the cold silage from along the walls and corners, and substituting that which is warm from the middle of the mass, seems a reasonable one and worthy of further trial. That it is not essential, however, to good sweet silage, our own experience has proved.

In case of an accident or break-down it will do no harm to suspend work for a day or two, but if left longer than this the silage to a depth of two or three inches usually begins to mould. When filling is completed a foot and one-half of chaffed straw, marsh hay or cornstalks will make a sufficient covering. The use of weights is now about obsolete. The silo should be examined daily for a couple of weeks, and the covering pressed down until the settling has ceased.

TWO CROPS IN THE SAME SILO.

The question is often asked if one crop can be placed on top of another in the silo, provided that the first has only partially filled it. Most certainly; if one crop, as clover, for example, only partly fills the silo, when the corn crop has matured the covering of the clover can be removed or left on, as desired, and the other crop placed on top of it. By filling at different times much more can be got into the silo than if a single crop is placed therein by rapid filling. Even with the slow filling silage settles considerably after the silo is closed up; with very rapid filling it may settle as much as two-fifths, or even one-half. Under any system it is well to allow two or three days' settling at the last and filling up again so as to get in all the feed possible.

Prof. Henry, who has made a very thorough study of the making and handling of ensilage regards the style of con-

struction shown in Prof. King's Bulletin (see pages 263, 264 and 265) as superior to the plans described in Mr. Adams' paper. The former represents the latest research in this important field; but the latter is of course interesting by way of comparison.

GENERAL INDEX.

FARM BARNS.

	PAGE
GENERAL REMARKS.....	9-13
ILLUSTRATED PLANS.....	9-38
Ayres, R. F.....	28-30
Coldren & Lee.....	31-34
Gaddy, Dr. N. D. (Farm and Sheep).....	34-38
Harrison, S. J.....	26-28
Missouri Agricultural College.....	13-26

CATTLE BARNs.

GENERAL REMARKS	39-45
ILLUSTRATED PLANS.....	83-112
Adams Luther	83-87
Barber, V.	90-93
Barclay, C. S.....	58-60
Brown, Geo. E. & Co. (Dairy).....	75-77
Clark, Thos.....	62-65
Clough, H. H.....	47-51
Crittenden, Orlando	60-62
Cunningham, D. E.....	69-71
Harris, W. A.....	42-43
Hamilton, W. W.....	92-96
Jones, T. C.....	45-47
King, C. E. (Dairy)	100-108
King, Will R.....	65-67
Lee, J. N.....	77-81
Macon County (Ill.) Poor Farm.....	90-93
Miller Barn at Gooderow, Ill.....	72-75
Miller & Sibley (Dairy).....	53-57
Moberley, T. S.....	96-100
Moore, Chas. F.....	81-83
Norton, C. W.....	67-69
Payne, E. W.....	51-53
Rice, C. S.....	87-90
Stevens, R. S. (Dairy).....	108-112

HORSE BARNs.

	PAGE
GENERAL REMARKS.....	113-115
ILLUSTRATED PLANS.....	115-153
Dunham, M. W.....	115-122
Dunham, M. W. (Colt).....	122-127
Fields, W. M. & Bro.....	127-130
Goodson, J. F.....	142-145
Jewett, H. C. & Co.....	137-142
Lee, J. N. (Cattle and Horse).....	77-81
Miller & Sibley.....	133-137
Nebraska Importing Company.....	148-151
Rich, M.....	151-153
Rundle, J. F.....	145-148
Stetson, E. & Sons.....	130-133

SHEEP BARNs, CORRALS, YARDS, ETC.

ILLUSTRATED PLANS.....	154-165
Adams, Leslie H.....	154-160
Gaddy, Dr. N. D. (and General Farm Barn).....	34-28
Hills, C. & Son.....	160-163
King, Will R.....	164-165
Rees, E. M.....	163-164
CORRAL AND SHEARING PENS.....	168-171
DIPPING FOR SCAB, DEVICE FOR.....	166-168, 171-174
FEEDING RACKS.....	157, 174-178

SWINE BARNs, PENS, ETC.

ILLUSTRATED PLANS.....	179-231
Coldren & Lee.....	224-227
Coleman, N.....	208-210
Martin, J. L.....	191-193
Moore, A. C. & Son.....	188-190
Rich, M.....	193-196
Street & Sons.....	179-183
Waugh, C. P.....	196-199
Wisconsin Agricultural College.....	183-188
BREEDING PENS FOR SOWS.....	230-231
CHEAP AND CONVENIENT PENS.....	203-207
CHEAP HOG HOUSE, A.....	207-208
CRIB, WAGON SHED AND PEN.....	215
FARROWING PENS.....	221-224
FROST-PROOF SWINE PEN, A.....	216-218
“HANDY, WARM, AND SUBSTANTIAL”.....	227-230

	PAGE
HOLDING HOGS, DEVICE FOR.....	247-248
MODEL HOG HOUSE, A.....	201-203
MOVABLE PIG HOUSE, A.....	210-215
MOVING HOGS, DEVICE FOR.....	243-246
PORTABLE PEN, A.....	199-200
RACK, HOG AND HAY COMBINED.....	241-243
SERVICE PEN AND BOX FOR BOAR.....	232-236
SLOP, DEVICE FOR KEEPING WARM.....	246-247
TROUGHS—Feeding.....	239-241
Hinged.....	186
Movable.....	238-239
WARMTH, SUNLIGHT AND EXERCISE, DEVICE FOR SECURING.....	236-237
WARM PENS AND HOW TO MAKE THEM.....	213-221

SILOS AND ENSILAGE.

Experience, Result of.....	249-269
Wood-Lined.....	250-251
Ventilation, Importance of.....	251-252
Painting.....	252-253
Stone and Grout.....	253-254
Lathing and Plastering.....	255
Linings for.....	256
Form and Dimensions of.....	256
Feeding from Top.....	257-258
Partitions, Use of.....	257-258
Some Things Essential.....	258
Covering of.....	258-259
Rats, Protection Against.....	259
Freezing, Protection Against.....	260
Wood Silos, Construction of.....	260-265
Lining, Expense of.....	265-266
Stone Silos.....	266-267
Cost, Comparative of Different Kinds.....	267-268
Building by Degrees.....	268
Repair of.....	268-269
Location of.....	269-270
Filling of.....	269
Form of.....	270
Joining Planks of Sill.....	271
Studding, Fastening and Bulging of.....	272
Lining.....	273-274
Painting.....	274-275
Boarding of Inside.....	275
Fodder-Corn—Handling of.....	276
Rack for Drawing.....	277

	PAGE
Rack for Drawing Fodder-Corn.....	277
Length to Cut Silage.....	277
Chute, Use of.....	278
Filling the Silo.....	278-279
Crops, Two in Same Silo.....	279

THEORY AND PRACTICE

— OF —

CATTLE-BREEDING,

BY WM. WARFIELD,

Staff Correspondent of "The Breeder's Gazette."

TABLE OF CONTENTS.

INTRODUCTION.

CHAP. I.—Breeding a Science and an Art.

PART I.—THE THEORY.

CHAP. II.—Heredity; the Breeder's Corner-Stone.

CHAP. III.—Atavism.

CHAP. IV.—Prepotency.

CHAP. V.—Variation.

PART II.—THE THEORY APPLIED.

CHAP. VI.—Introduction to Principles of Breeding.

CHAP. VII.—In-and-In Breeding.

CHAP. VIII.—Line-Breeding.

CHAP. IX.—Natural Breeding.

CHAP. X.—Historical Testimony.

CHAP. XI.—Cross-Breeding.

CHAP. XII.—Grade Breeding.

CHAP. XIII.—Pedigree.

PART III.—THE PRACTICE.

CHAP. XIV.—Introduction to the Practice of Breeding
Methods.

CHAP. XV.—The Selection of Breeding Animals.

CHAP. XVI.—The Selection of Breeding Animals (Contin-
ued).

CHAP. XVII.—Shelter.

CHAP. XVIII.—General Care and Attention.

CHAP. XIX.—Feeding Methods.

Price, \$2, post-paid. Address

J. H. SANDERS PUB. CO., Chicago.

THE BREEDER'S GAZETTE,

An Illustrated Weekly of from 24 to 28 pages,

IS CONCEDED TO BE

The Foremost Farm AND Stock Journal of the Day.

IT MAKES A SPECIALTY OF

LIVE STOCK, CROP AND MARKET REPORTS,

AND ITS

Discussions of Feeding Problems

ARE THE MOST VALUABLE NOW APPEARING IN

The Entire American Agricultural Press.

It treats of beef, pork and mutton-making; the breeding and management of both beef and dairy cattle, sheep and swine, and in all things pertaining to

HORSE-BREEDING,

whether relating to draft, coach or trotting stock, it is recognized authority.

SUBSCRIPTION RATES :

Single Subscription, one year,	-	\$2.00
In Clubs of five, one year (each),	-	1.50

Agents wanted everywhere. Sample copies on application. Address

J. H. SANDERS PUBLISHING CO.,
CHICAGO, ILL.

HORSE-BREEDING,

— AND THE —

MANAGEMENT OF STALLIONS, BROOD MARES AND FOALS,

By J. H. SANDERS, Founder of "The Breeder's Gazette."

The character and scope of this work may be gathered from the following

TABLE OF CONTENTS :

- CHAPTER I.—GENERAL PRINCIPLES OF BREEDING.—General laws of heredity; causes of variation from original types; modifications from changed conditions of life; accidental variations, or sports; extent of hereditary influence; the formation of breeds; inbreeding and crossing; value of pedigree; relative size of sire and dam; influence of first impregnation; effect of imagination on color of progeny; effect of change of climate on the generative organs; controlling the sex.
- CHAPTER II.—BREEDS OF HORSES.—Thoroughbreds; Trotters and Roadsters; Orloffs, or Russian Trotters; Cleveland Bays; Shire or Cart horses; Clydesdales; Percherons; other breeds.
- CHAPTER III.—STALLIONS, BROOD MARES AND FOALS.—Selection of breeding stock.
- THE STALLION.—General Management of the stallion; controlling the stallion when in use; when mares should be tried; the number of mares to be served; effect of age on the fertility of the stallion; effect of age on the quality of the get; percentage of foals to mares served; management of the stallion after the season closes; effects of castration on stallions; fighting between stallions.
- THE BROOD MARE.—Causes of barrenness in brood mares; the productive period in brood mares; time of foaling and period of gestation; general suggestions as to food and nursing.
- THE FOAL.—Feeding the young foal; weaning the foal; effect of exercise on development; breaking the foal; views of Dr. Reynolds of Liverpool on horse-breeding.
- CHAPTER IV.—DISEASES PECULIAR TO BREEDING STOCK.—Hygiene of the eye; the eye as affected by the teeth; umbilical hernia in young foals; "scours" or diarrhoea in colts; strangles or distemper.
- THE STALLION.—External injuries; inflammation of the penis; inflammation of the testicles; cancer of the penis and sheath; prolapse or paralysis of the penis; scrotal hernia; waterbag, so-called; excessive venery; non-emission of semen (proudness, so-called); sexual sluggishness; spermatorrhoea; vesicular eruptions on the penis; foul sheath; masturbation; cryptorchids (ridglings, so-called).
- THE BROOD MARE.—Barrenness; nymphomania; tumors within the vagina and uterus; leucorrhoea, or so-called whites; colt founder, so-called; oedema during pregnancy; superimpregnation; heat during pregnancy; laceration of the rectum; abortion; difficult parturition; laceration of the perinæum. (Nearly all of this chapter was written especially for this work by Dr. N. H. Paaren, M. D., late State Veterinarian of Illinois.)
- APPENDIX.—FRENCH COACH HORSES.—DENTITION OF HORSES (profusely illustrated).—STALLION BRIDLE (illustrated).

Price, \$2 post-paid. Address

J. H. SANDERS PUB. CO., Chicago, Ill.

631.2

83

J. H. SANDERS

Autor

Practical Hints about Barn Buil-

Título
ding

Nº cons.	Assinatura	Data
	<i>J. H. Sanders</i>	24/9/82

ORIENTAÇÕES PARA O USO

Esta é uma cópia digital de um documento (ou parte dele) que pertence a um dos acervos que fazem parte da Biblioteca Digital de Obras Raras e Especiais da USP. Trata-se de uma referência a um documento original. Neste sentido, procuramos manter a integridade e a autenticidade da fonte, não realizando alterações no ambiente digital – com exceção de ajustes de cor, contraste e definição.

1. Você apenas deve utilizar esta obra para fins não comerciais. Os livros, textos e imagens que publicamos na Biblioteca Digital de Obras Raras e Especiais da USP são de domínio público, no entanto, é proibido o uso comercial das nossas imagens.

2. Atribuição. Quando utilizar este documento em outro contexto, você deve dar crédito ao autor (ou autores), à Biblioteca Digital de Obras Raras e Especiais da USP e ao acervo original, da forma como aparece na ficha catalográfica (metadados) do repositório digital. Pedimos que você não republique este conteúdo na rede mundial de computadores (internet) sem a nossa expressa autorização.

3. Direitos do autor. No Brasil, os direitos do autor são regulados pela Lei n.º 9.610, de 19 de Fevereiro de 1998. Os direitos do autor estão também respaldados na Convenção de Berna, de 1971. Sabemos das dificuldades existentes para a verificação se uma obra realmente encontra-se em domínio público. Neste sentido, se você acreditar que algum documento publicado na Biblioteca Digital de Obras Raras e Especiais da USP esteja violando direitos autorais de tradução, versão, exibição, reprodução ou quaisquer outros, solicitamos que nos informe imediatamente (dtsibi@usp.br).